



System Management

System Management Automated Real-Time Systems (SMARTS)

B2B Web Service Specification

for

Market Participant Dispatch Instructions

Release Date: 15 November 2012

Document Version: Public v3.5

Date: 4 July 2013

**UNCONTROLLED DOCUMENT WHEN PRINTED.
DO NOT RELY ON PRINTED COPY.**

About this document

Author/Custodianship

Author:	Brett Di Lello
Custodian:	Neil Hay

Distribution list

Name	Position/title
Neil Hay	Manager Market Operations
Clayton James	System Operations Control Section Leader
James Shirley	Senior Engineer - SCADA & Information Systems
Mark Allen	Market Business Analyst

Document version history

Version	Date	Change #	Amendment
0.1	05/11/2012	N/A	Draft for internal review.
0.2	7/11/2012	N/A	Incorporation of feedback supplied by multiple reviewers including: <ul style="list-style-type: none"> Numerous content updates & refinements. Creation of diagrams & scenario's. Further descriptions of protocols & gateway information. Updates to & formatting of data sets and samples.
FINAL	12/11/2012	N/A	Final incorporation of feedback & content refinements in preparation for stakeholder endorsement. Additional image update performed.
FINAL	13/11/2012	N/A	Additional Updates from feedback: <ul style="list-style-type: none"> CONSUMER/PROVIDER in diagrams update. W3 time formats change YYYY-MM-DDThh:mm:ss.sTZD (eg 1997-07-16T19:20:30.45+01:00). Trade date removal. All data types in SOAP/XML Schema types.
2	20/02/2013	N/A	Technical Requirements Appendix Added

Version	Date	Change #	Amendment
3	06/03/2013	N/A	<p>Updated to reflect design changes.</p> <ol style="list-style-type: none"> 1. Use of Trading Networks as a single end point for receipt of Dispatch instruction Acknowledgements 2. Extension of schema for Dispatch Instruction issue to include references to any Dispatch Instruction under variation. 3. Removed references to Integration Server 4. Removed mandate on response must be via B2B 5. Added requirement that response must be within 1 minute 6. Removed references to service registry 7. Added detailed element definitions 8. Added copies of XSD and WSD 9. Added reference to use of B2B Gateway
3.1	16/04/2013	N/A	Namespace prefix updated to align with emerging internal standard
3.2	24/05/2013	N/A	<p>Added missing WADL.</p> <p>Corrected malformed facet on responseCodeType which was forcing a mandatory 5 character value instead of up to 5.</p> <p>Added more references to use of B2B Gateway</p>
3.3	30/05/2015	N/A	Grammatical corrections made
3.4	13/06/2013	N/A	<p>Removed xsd/wSDL/wadl excerpts</p> <p>Mandated usage of mutual certificate authentication</p> <p>Supply proposed endpoint for the B2B Gateway</p>
3.5	03/07/2013	N/A	Replaced embedded documents with URLs so document can be distilled to a PDF

Related/referenced documents

Document title	Document link (DMS #)
WEM Market Rules	http://www.imowa.com.au
ELECTRICITY INDUSTRY (WHOLESALE ELECTRICITY MARKET) REGULATIONS 2004 WHOLESALE ELECTRICITY MARKET AMENDING RULES (1 November 2012)	http://www.imowa.com.au/f769,2885351/WEM_Rules_Unofficial_20121101.docx
ELECTRICITY INDUSTRY (WHOLESALE ELECTRICITY MARKET) REGULATIONS 2004 WHOLESALE ELECTRICITY MARKET RULES Power System Operation Procedure: Dispatch	http://www.imowa.com.au/f709,2377918/Dispatch_PSOP_July_2012.pdf

Business Unit/ Representative Endorsements

Acceptor ID	Role	Name	Signature	Date
1	General Manager System Management	Cameron Parrotte		___/___/___
2	Manager Market Operations	Neil Hay		___/___/___
3	System Operations Control Section Leader	Clayton James		___/___/___
4	SCADA & IS Infrastructure Manager	Julian Rouse		___/___/___

Comments

Acceptor ID	Comments

Table of Contents

1	ACRONYMS & DEFINITIONS OF TERMS	7
2	DOCUMENT CONTEXT	8
2.1	INTENDED AUDIENCE	8
2.2	MARKET GOVERNANCE.....	8
2.3	ASSUMPTIONS.....	8
2.4	EXCLUSIONS	8
3	BACKGROUND	9
3.1	WHAT ARE B2B WEB SERVICES?.....	9
3.1.1	<i>Provider Web Service</i>	10
3.1.2	<i>Consumer Web Service</i>	10
3.1.3	<i>B2B Gateway</i>	10
3.1.4	<i>Applied Context</i>	10
3.2	BENEFITS OF WEB SERVICES.....	11
4	BUSINESS PERSPECTIVE - DISPATCH INSTRUCTIONS.....	12
4.1	EXPECTED OUTCOMES	12
4.2	BUSINESS RULES	12
4.3	OPERATIONAL PROCESS.....	12
4.3.1	<i>Dispatch Instruction</i>	12
4.3.2	<i>Dispatch Acknowledgement</i>	13
4.3.3	<i>Dispatch Variation (Non-Compliant Response)</i>	13
5	SERVICE SPECIFICATION - DISPATCH INSTRUCTIONS.....	14
5.1	WEB SERVICES SPECIFIED	14
5.2	SECURITY	14
5.3	WEB SERVICE FORMAT.....	14
5.3.1	<i>Structure</i>	14
5.3.1.1	Issue Dispatch Instruction	14
5.3.1.1.1	Request.....	14
5.3.1.1.2	Response	14
5.3.1.2	Dispatch Instruction Acknowledgement	15
5.3.1.2.1	Request.....	15
5.3.1.2.2	Response	15
5.4	ELEMENT DEFINITIONS	15
5.4.1	<i>Global Elements/Types</i>	15
5.4.1.1	Element tns:transaction	15
5.4.1.2	Type tns:keyValueType	16
5.4.1.3	Type tns:resourceType.....	16
5.4.1.4	Type tns:dispatchVariationType	16
5.4.2	<i>Dispatch Instruction Elements</i>	17
5.4.2.1	Request Element tns:issueDispatchInstruction	17
5.4.2.2	Response Element tns: issueDispatchInstructionResponse	18
5.4.3	<i>Dispatch Acknowledgement Elements</i>	18
5.4.3.1	Request Element tns: dispatchInstructionAcknowledgement	18
5.4.3.2	Response	19
5.5	SAMPLE REQUESTS.....	19
5.5.1	<i>Issue Dispatch Instruction</i>	19
5.5.2	<i>Dispatch Instruction Acknowledgment</i>	20
5.6	SAMPLE RESPONSE.....	20
5.6.1	<i>Issue Dispatch Instruction</i>	20
5.6.2	<i>Dispatch Instruction Acknowledgment</i>	21
6	B2B GATEWAY INTERACTION	22

6.1	SYSTEM MANAGEMENT	22
6.2	MARKET PARTICIPANT	22
6.3	USAGE.....	22
6.3.1	<i>Endpoint</i>	22
6.3.2	<i>WAD</i>	22
6.3.2.1	Example DI Acknowledgement Built from WAD	22
6.3.3	<i>Message Exchange</i>	23
6.3.3.1	SOAP and Gateway	23
6.3.3.2	Gateway and Gateway	23
7	SERVICE CONTRACT FILES	24
7.1	DISPATCH INSTRUCTION XSD	24
7.2	DISPATCH INSTRUCTION WSD	24
7.3	B2B GATEWAY WADL	24

1 Acronyms & Definitions of Terms

Business Day	A business day is defined as a weekday (Monday to Friday) excluding Western Australian public holidays.
Dispatch Instruction	An instruction issued by System Management to a Market Participant, directing the Market Participant to vary the output or consumption of one of its Registered Facilities.
Dispatch Acknowledgement	A compliant or non-compliant response to System Management from a Market Participant to a specific Dispatch Instruction.
Dispatch Variation	Dispatch Instruction that does not require acknowledgement from a Market Participant resulting from a non-compliant Dispatch Acknowledgement.
EPCC	East Perth Control Centre is the operations base of Western Power's System Management division.
IMO	Independent Market Operator.
Market Systems	Refers to the collection of applications and databases that provide Electricity Market functionality to support System Management the Market Entity.
NN	Not Null.
P&MO	Planning and Market Operations section of Western Power's System Management division – the core of the System Management market entity.
RTDE	Real Time Dispatch Engine – a software component of the SMARTS program providing dispatch related functionality for SM system operation controllers.
SCADA	Supervisory Control and Data Acquisition.
SCADA & IS	SCADA & Information Systems section of Western Power's System Management division. They operate the SCADA system of the SWIS and supporting IT systems, networks and infrastructure at EPCC.
SMARTS	System Management Automated Real-Time Systems – systems post June 2012.
SMMITS	System Management Market IT System – systems prior to June 2012.
Trading Day	A trading day is defined as a 24 hour period from 08:00 on a day to 07:59:59 on the following day and is assigned the date on which it begins.
UK	Unique Key.
WEM	Wholesale Electricity Market (in Western Australia).
WSC	Web Service Connector.
WSD	Web Service Descriptor.
WSDL	Web Services Description Language.
WPC	Western Power Corporation, Australia.
XML	Extensible Mark-up Language
XSD	XML Schema Definition
WAD	Web Application Definition

2 Document Context

The context of this document provides the following summary:

- To document and communicate the specific business requirements associated with;
 - supporting System Operations Controllers in making Dispatch decisions.
 - creating and issuing Dispatch Instructions to Market Participants.
- To design, develop and deploy an integrated long-term solution.
- To reduce reliance on manual activities, with its attendant risks, wherever possible.
- To align systems with current processes and procedures whilst accounting for changes inherent with the move from the “transitional market” to the “full” competitive balancing market; and
- Retire business reliance on legacy systems associated with dispatch.

2.1 Intended Audience

The audiences this document is intended for are grouped in the following bodies of representation:

1. The Independent Market Operator;
2. Market Participants;
3. Rule Participants;
4. Technical Resources representing Market Participants;
5. System Management.

2.2 Market Governance

The content provided within this specification was derived and follows rules prescribed within;

Chapter 7 Dispatch,

of the following publically available document:

ELECTRICITY INDUSTRY ACT

ELECTRICITY INDUSTRY (WHOLESALE ELECTRICITY MARKET) REGULATIONS 2004

WHOLESALE ELECTRICITY MARKET AMENDING RULES (1 November 2012)

2.3 Assumptions

In creating the content contained within this document, the following assumptions have been made:

1. Market Participants are aware that the Web Services specified within this document will NOT be available for use until at least six (6) months from the date of formal approval.
2. The B2B Web Services being provisioned in the future will be facilitating a two (2) way data/ information exchange between System Management and Market Participants.
3. Market Participants have appropriately skilled technology resources to enable their capacity to facilitate the required two (2) way data/ information exchange between themselves and System Management.

2.4 Exclusions

1. Any interaction/ data exchanges specific between System Management and Market Participants other than those through the B2B gateway are explicitly excluded from this document.
2. Any internal process/ interaction or decisions made by System Management or Market Participants prior to the delivery of the document types (e.g. Dispatch Instruction) to the B2B gateway fall outside the scope of this document.
3. The carrier selected or associated with the consumption and provision of Web Services does not form part of this specification.

3 Background

System Management is a ring-fenced business within Western Power with a role, defined by the WEM (Wholesale Electricity Market) Rules, of System Operator for the South West Interconnected System. System Management (the market entity) develops and maintains IT systems to enable its market functions and facilitate communication with market participants and the Independent Market Operator.

The SMARTS Program of works commenced in 2011 will expand, modify and develop new market systems to address the requirements of WEM rule changes (RC_2011_10) to address the needs of System Management in relation to the introduction of Competitive Balancing and Load Following in the WEM.

As part of the SMARTS Release B programme of work, by November 15th 2012, System Management has committed to provide Market Participants with documented specifications of specific Web Services which will be available in the future.

By delivering these specifications System Management will;

- Deliver upon a commitment made to the IMO and Market Participants.
- Simplify file exchange capacities and leverage standardised file/ data transfer technologies.
- Improve their ability to comply with Market Rules within dispatch processes.

3.1 What are B2B Web Services?

Web Services are building blocks for creating open, distributed systems. A Web Service is a collection of functions that are packaged as a single unit and published to a network for use by other software programs. For example, you could create a Web Service that checks a customer's credit or tracks delivery of a package. If you want to provide higher-level functionality, such as a complete order management system, you could create a Web Service that maps to many business services, each performing a separate order management function.

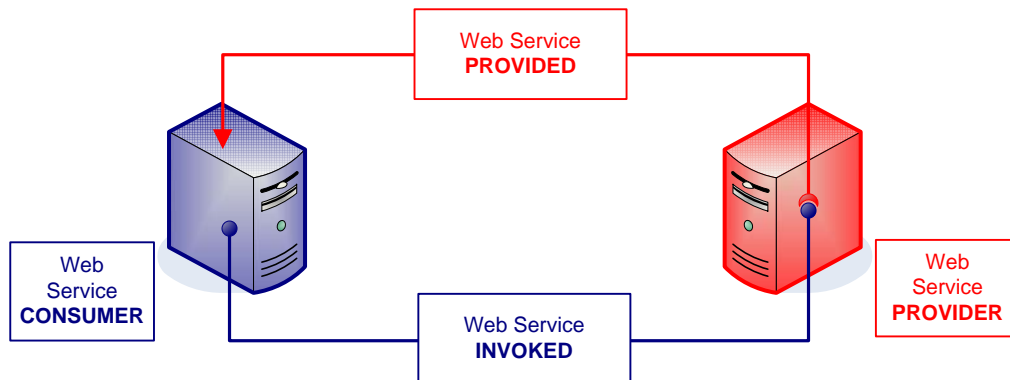

Image 1 - Web Service File Exchange Example

In System Management's future implementation of Web Services, Web Service Descriptors (WSD) and XML Schema Definitions (XSD) will be used to encapsulate information about the available services and processes and use Web Service Connectors (WSC) or B2B Gateways to provide and invoke services to and from Market Participants.

The WSD encapsulates all the information required by the provider or the consumer (requester) of a Web Service. The WSD contains the message formats, data types, transport protocols, and transport serialization formats that should be used between the consumer (requester) and the provider of the Web Service. It also specifies one or more network locations at which a Web Service can be invoked.

In essence, the WSD represents an agreement governing the mechanics of interacting with that service and an XSD describes the composition of the message being exchanged.

3.1.1 Provider Web Service

A provider Web Service Descriptor defines a Web Service that is hosted on Server and a service “provided” to external users.

A provider Web Service Descriptor will expose one or more services as operations. External users can invoke the services remotely.

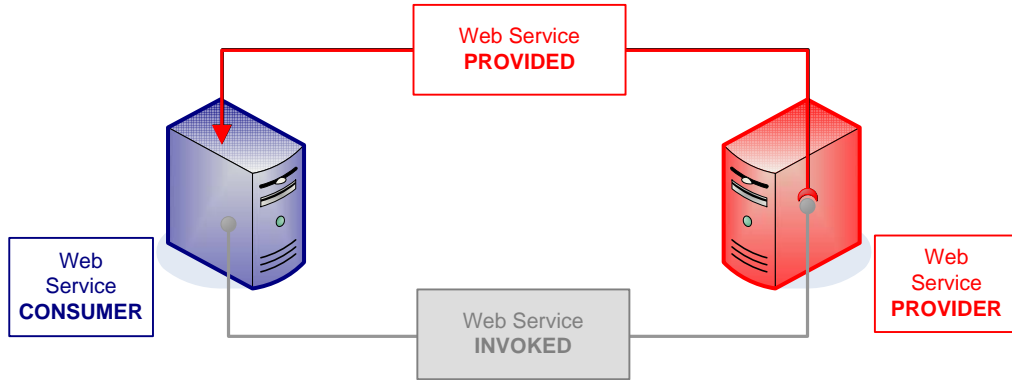

Image 2 - Web Service Provider

3.1.2 Consumer Web Service

A consumer Web Service Descriptor defines an external Web Service, allowing a Server to create a Web Service Connector (WSC) for each operation in the Web Service.

The Web Service Connector(s) can be used just like any other service; when a connector is invoked it calls a specific operation of a Web Service.

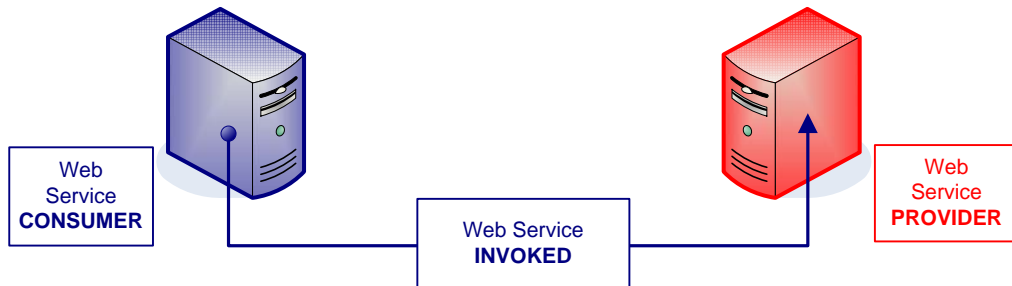

Image 3 - Web Service Consumer

3.1.3 B2B Gateway

A B2B Gateway is a generic service implementation that allows for the asynchronous exchange of Business documents. The preferred format of these messages is XML. A gateway can be used in place of a WSD and the operations it describes but making use of the XSD which describes the Business documents.

3.1.4 Applied Context

In the context of Dispatch Instruction's and Dispatch Variation's and by applying the examples above, the following scenario's will exist:

1. The Web Service Descriptor/endpoint for the Dispatch Instruction service will be provided by the Market Participants (as System Management will be the consumer of these services).
2. A B2B Gateway endpoint for the Dispatch Acknowledgement service will be provided by System Management (as Market Participants will be the consumer of this service) whereby a message conforming to the `tns:dispatchInstructionAcknowledgement` document definition can be sent.

3.2 Benefits of Web Services

Aside from the advantages gained by implementing viable technologies to improve business efficiency, additional positive benefits include:

- A greater transparency of System Management decisions relating to power system management;
- The automation of repeatable decisions to improve decision consistency;
- An increased reliability of auditable data sources; and thus resulting in
- Improved WEM rule compliance.

4 Business Perspective - Dispatch Instructions

4.1 Expected Outcomes

- The design, development and deployment of integrated long-term solution.
- Reduced reliance on manual activities, with its attendant risks, wherever possible;
- Alignment of systems with current processes and procedures with the flexibility to adapt from the “transitional market” to the “full” competitive balancing market; and
- The retirement of business reliance on legacy systems and technologies associated with dispatch.

4.2 Business Rules

The following business rules apply when using System Management’s B2B Web Services. In the context of this specification document, Dispatch Instructions, Dispatch Variations and Dispatch Acknowledgements.

1. A Market Participants MUST define their primary communication mechanism for file/ data exchange or interaction.
i.e. B2B Web Services, MPI Portal etc.
2. System Management’s communication mechanism for file/ data interaction or exchange with Market Participants are resource specific.
3. System Management will manage a Market Participant resource’s preferred communication mechanism for file/ data interaction or exchange.
4. Acknowledgement to a Dispatch Instruction must occur within one minute of the Dispatch Instruction transmission date/time in order to meet compliance.
5. Dispatch Variations are to be RECEIVED ONLY by Market Participants and NO RESPONSE IS REQUIRED.

4.3 Operational Process

The following images describe the sequence of events associated with the Dispatch Instructions Web Service. Whilst a request response message exchange pattern is to be used each event is expected to be asynchronous in nature.

- Dispatch Instructions sent to Market Participant.
- Compliant or Non-Compliant Dispatch Acknowledgement provided by Market Participant.
- Dispatch Variation sent to Market Participant based on Non-Compliant Dispatch Acknowledgement.

4.3.1 Dispatch Instruction

Send Dispatch Instruction to Market Participant.

(System Management consumes Web Service from Market Participant)

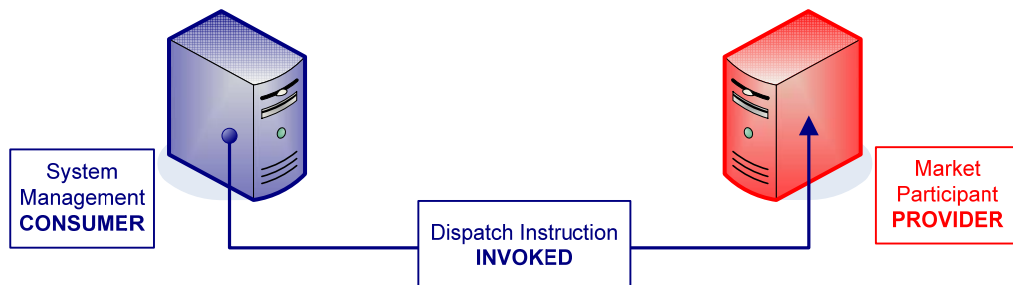

Image 4 - Dispatch Instruction Issued

4.3.2 Dispatch Acknowledgement

Receive Dispatch Acknowledgement from Market Participant.

(Market Participant consumes B2B Gateway Service from System Management)

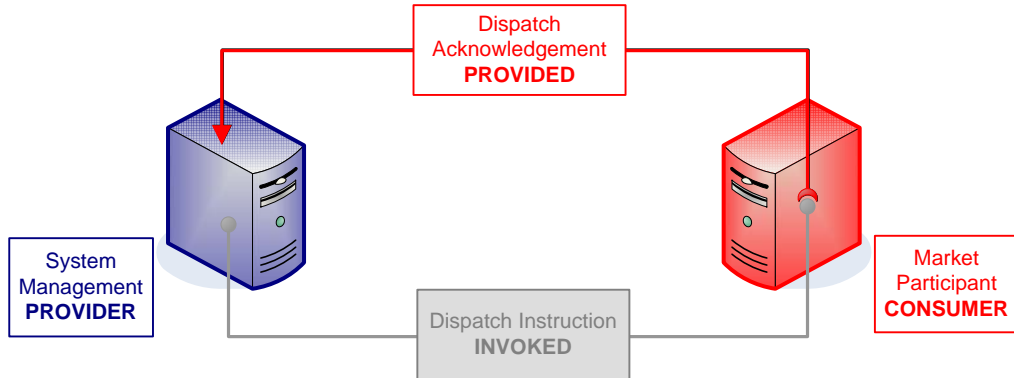

Image 5 - Dispatch Acknowledgement Provided

4.3.3 Dispatch Variation (Non-Compliant Response)

When a Dispatch Acknowledgement received from a Market Participant is deemed **Non-Compliant**, a Dispatch Instruction will be issued to the Market Participant containing the variation identified within the acknowledgement.

NOTE: NO ACKNOWLEDGEMENT REQUIRED FOR A DISPATCH VARIATION.

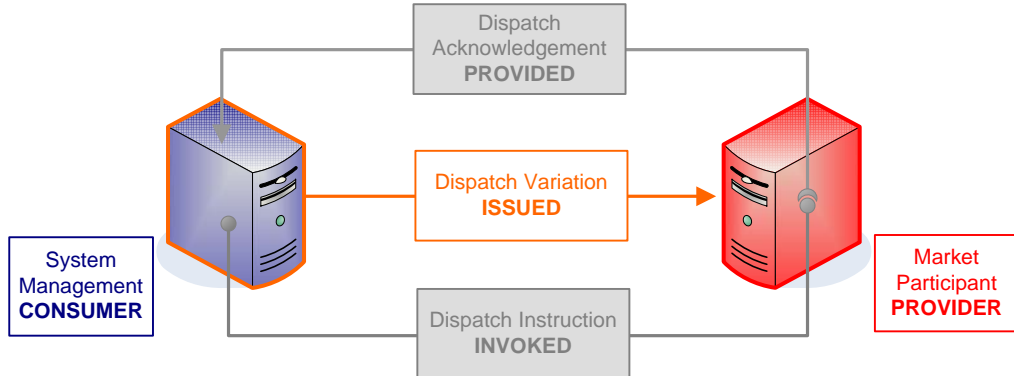

Image 6 - Dispatch Variation Issued

5 Service Specification - Dispatch Instructions

A Dispatch Instruction is an instruction issued by System Management to a Market Participant, other than Verve Energy in respect of its Verve Energy Balancing Portfolio, directing that the Market Participant vary the output or consumption of one of its Registered Facilities

Where a Participant can offer a B2B gateway then Dispatch instructions can be sent to this in place of providing a Web Service based on the accompanying WSD.

5.1 Web Services Specified

1. Issue Dispatch Instruction - Send To Participant.
2. B2B Gateway – Participant delivers Dispatch Instruction Acknowledgement document

5.2 Security

Web Service and B2B Gateways connections will use SSL to secure the interface. Mutual certificate authentication shall be utilised and basic authentication may also be enforced.

Section 6.3.1 contains further details for communicating with the B2B Gateway.

5.3 Web Service Format

5.3.1 Structure

5.3.1.1 Issue Dispatch Instruction

The following tables contain the details of the structure of elements that comprises a Dispatch Instruction/ Dispatch Variation, and the number of times that each element can occur within the containing element.

5.3.1.1.1 Request

The request is composed of an element for B2B transaction information and the related instruction data

Element	Min Occurs	Max Occurs
tns:issueDispatchInstruction	1	1
tns:transaction	1	1
tns:instruction	1	1

Table 5-1 Dispatch Instruction Request

5.3.1.1.2 Response

The following service response, used as proof of receipt, must be returned where a Participant exposes a service based upon the WSD. Where a B2B gateway has been provisioned then a http response code of 200 is expected as confirmation of receipt.

Element	Min Occurs	Max Occurs
tns:issueDispatchInstructionResponse	1	1
tns:response	1	1

Table 5-2 Dispatch Instruction Response

5.3.1.2 Dispatch Instruction Acknowledgement

The Dispatch Instruction Acknowledgement is received via System Managements B2B gateway. Detailed usage and a WAD are provided section 6, B2B Gateway Interaction.

5.3.1.2.1 Request

The request is composed of an element for B2B transaction information and the related acknowledgement data

Element	Min Occurs	Max Occurs
tns:dispatchInstructionAcknowledgement	1	1
tns:transaction	1	1
tns:acknowledgement	1	1

Table 5-3 Dispatch Instruction Acknowledgement Request

5.3.1.2.2 Response

Owing to the generic nature of the B2B gateway, expect a http response code of 200. The following content is also returned.

Element	Min Occurs	Max Occurs
Values	1	1
record	1	1

5.4 Element Definitions

The following table describes constraint codes used when describing the elements.

Code	Definition
NN	Not Null
UK	Unique Key
O	Optional
UB	Unbounded

5.4.1 Global Elements/Types

See attached XSD for details on simple type. These are types used to describe an element without a corresponding table describing it; e.g. tns:responseTimeType

5.4.1.1 Element tns:transaction

This element provides a structure for the transport of B2B specific information

Element	XML Data Type	Max. Field Length	Constraints	Comments
tns:senderId	string		NN	Market Participant identifier of message transmitter

Element	XML Data Type	Max. Field Length	Constraints	Comments
tns:receiverId	string		NN	Market Participant identifier of message target
tns:messageType	string		O	Used to identify message class or process or purpose. Not required for Dispatch instructions
tns:transactionId	string		O, UK	Unique identifier for a message exchange/business conversation. In context of DI should be set to the Dispatch Instruction ID
tns:parameters	tns:keyValueType		O, UB	Generic metadata transport. Not used for DI
tns:routingType	tns:keyValueType		O	Additional information to assist in the routing of the message. Expect B2B for DI
tns:transactionDateTime	dateTime		NN	The date/time that the message was composed for transmission

5.4.1.2 Type *tns:keyValueType*

Element	XML Data Type	Max. Field Length	Constraints	Comments
tns:key	string		NN	Field name/identifier
tns:value	string		O	Field value

5.4.1.3 Type *tns:resourceType*

Element	XML Data Type	Max. Field Length	Constraints	Comments
tns:participantName	tns:participantNameType	12	NN	Market supplied participant short name
tns:resourceId	tns:resourceIdType	15	NN	Market supplied resource identifier
tns:resourceName	tns:resourceNameType	32	NN	Market supplied resource name

5.4.1.4 Type *tns:dispatchVariationType*

Element	XML Data Type	Max. Field Length	Constraints	Comments
tns:resource	tns:resourceType		NN	Describes resource that was dispatched to

tns:instructionId	tns:instructionIdType	15	NN	DI that variation has been made against
tns:issuedDateTime	dateTime		NN	Original DI issue date/time

5.4.2 Dispatch Instruction Elements

5.4.2.1 Request Element *tns:issueDispatchInstruction*

The request message is composed of the tns:transaction (See Global Elements/Types for definition) and the tns:instruction elements, described below.

Element	XML Data Type	Max. Field Length	Constraints	Comments
tns:transaction	tns:transaction		NN	B2B Transaction information
tns:instruction	tns:dispatchInstructionType		NN	Dispatch Instruction Data
tns:dispatchInstructionType				
tns:resource	tns:resourceType		NN	Describes resource being dispatched to
tns:instructionId	tns:instructionIdType	15	UK, NN	Unique DI identifier
tns:issuedDateTime	dateTime		NN	Date/time that DI was issued
tns:responseDateTime	tns:responseTimeType		NN	The time at which to commence movement to the indicated output
tns:targetMw	tns:targetMwType	9.3	NN	Target output that Market Participant should move too
tns:rampRate	tns:rampRateType	9.3	NN	The rate at which the movement should be made
tns:instructionVariation	tns:instructionVariationType		NN	Flag indicating whether this DI is a result of a variation. True/false. The participant should use this field to determine whether an acknowledgement is required.
tns:instructionReason	tns:instructionReasonType	250 (Preserve)	O	Additional comments supporting reason for DI
tns:referenceDispatchInstruction	tns:dispatchVariationType		O	This type is used as reference to the Dispatch Instruction where a non-compliance has been encountered. Should only be present where tns:instructionVariation is true.

5.4.2.2 Response Element *tns: issueDispatchInstructionResponse*

The response to the issueDispatchInstruction request serves to indicate receipt of the message and does not imply acknowledgement

Element	XML Data Type	Max. Field Length	Constraints	Comments
tns:response	tns:responseHeaderType		NN	Describes resource that was dispatched to
tns:responseHeaderType				
tns:responseCode	tns:responseCodeType	5	NN	It is expected that successful processing will result in a response code of 0, all other codes be agreed upon between parties as required
tns:responseCodeDesc	string	250 (preserver)	O	It is expected, though not enforced that this will be populated whenever there is a non-zero response code
tns:receivedDateTime	dateTime		NN	Date/time message was received by participant
tns:executionTime	tns:executionTimeType		O	Optional field that indicates time taken to process receipt of message.

5.4.3 Dispatch Acknowledgement Elements

The date/time of the response will be determined at time of receipt of the acknowledgement request message.

5.4.3.1 Request Element *tns: dispatchInstructionAcknowledgement*

The request message is composed of the tns:transaction (See Global Elements/Types for definition) and the tns:acknowledgement elements, described below.

Element	XML Data Type	Max. Field Length	Constraints	Comments
tns:transaction	tns:transaction		NN	B2B Transaction information
tns:acknowledgement	tns:dispatchAcknowledgementType		NN	Dispatch Instruction Acknowledgement Data
tns:dispatchAcknowledgementType				
tns:instructionId	tns:instructionIdType	15	UK, NN	Unique DI identifier. This should be the same as the value sent in the corresponding issue message.

tns:targetMw	tns:targetMw Type	9.3	NN	Target output that Market Participant should will move too
tns:rampRate	tns:rampRate Type	9.3	NN	The rate at which the movement will be made
tns:participantReference	tns:participantReferenceType	50 (preserve)	O	Any reference from the participant that may be pertinent to the request.

5.4.3.2 Response

The response acts purely as a receipt of the request message where the http response code is 200. The response is generic in nature as provided by System Management's Enterprise Service Bus vendor. Any other http code indicates there has been an issue in accepting the message for processing.

5.5 Sample Requests

5.5.1 Issue Dispatch Instruction

```

<SOAP-ENV:Envelope xmlns:SOAP-ENV="http://schemas.xmlsoap.org/soap/envelope/" xmlns:SOAP-ENC="http://schemas.xmlsoap.org/soap/encoding/" xmlns:xsi="http://www.w3.org/2001/XMLSchema-instance" xmlns:xsd="http://www.w3.org/2001/XMLSchema" xmlns:tns="http://sm.westernpower.com.au/operations.dispatchinstructions.v1">
  <SOAP-ENV:Body>
    <sm:issueDispatchInstructionRequest xmlns:sm="http://sm.westernpower.com.au/operations.dispatchinstructions.issue.v1">
      <tns:issueDispatchInstruction>
        <tns:transaction>
          <tns:senderId>SenderBusinessAssociateID</tns:senderId>
          <tns:receiverId>ReceiverBusinessAssociateID</tns:receiverId>

          <tns:messageType>wp.activity.dispatchinstruction.doc.issueDispatchInstruction</tns:messageType>
          <tns:transactionId>10256</tns:transactionId>
          <tns:parameters />
          <tns:routingType>
            <tns:key>B2B</tns:key>
            <tns:value />
          </tns:routingType>
          <tns:transactionDateTime>2013-03-12T09:20:00.000+08:00</tns:transactionDateTime>
        </tns:transaction>
        <tns:instruction>
          <tns:resource>
            <tns:participantName>Some Generator</tns:participantName>
            <tns:resourceId>45897</tns:resourceId>
            <tns:resourceName>BigTurbine1</tns:resourceName>
          </tns:resource>
          <tns:instructionId>10256</tns:instructionId>
          <tns:issuedDateTime>2013-03-12T09:20:00.000+08:00</tns:issuedDateTime>
          <tns:responseDateTime>2013-03-12T09:30:00.000+08:00</tns:responseDateTime>
          <tns:targetMw>123456.123</tns:targetMw>
          <tns:rampRate>123456.123</tns:rampRate>
          <tns:instructionVariation>false</tns:instructionVariation>
          <tns:instructionReason>That time of the day</tns:instructionReason>
          <tns:referenceDispatchInstruction />
        </tns:instruction>
      </tns:issueDispatchInstruction>
    </sm:issueDispatchInstructionRequest>
  </SOAP-ENV:Body>
</SOAP-ENV:Envelope>

```

5.5.2 Dispatch Instruction Acknowledgment

```
<?xml version="1.0" encoding="UTF-8"?>
<tns:dispatchInstructionAcknowledgement xmlns:tns="http://sm.westernpower.com.au/operations.dispatchinstructions.v1">
  <tns:transaction>
    <tns:senderId> SenderBusinessAssociateID </tns:senderId>
    <tns:receiverId> ReceiverBusinessAssociateID </tns:receiverId>

    <tns:messageType>wp.activity.dispatchinstruction.doc.issueDispatchInstructionAcknowledgement</tns:messageType>
    <tns:transactionId>10256</tns:transactionId>
    <tns:parameters />
    <tns:routingType>
      <tns:key>B2B</tns:key>
      <tns:value/>
    </tns:routingType>
    <tns:transactionDateTime>2013-03-12T09:20:30.023+08:00</tns:transactionDateTime>
  </tns:transaction>
  <tns:acknowledgement>
    <tns:instructionId>10256</tns:instructionId>
    <tns:targetMw>123456.123</tns:targetMw>
    <tns:rampRate>123456.123</tns:rampRate>
    <tns:participantReference/>
  </tns:acknowledgement>
</tns:dispatchInstructionAcknowledgement>
```

5.6 Sample Response

5.6.1 Issue Dispatch Instruction

```
<soapenv:Envelope xmlns:soapenv="http://schemas.xmlsoap.org/soap/envelope/">
  <soapenv:Body>
    <sm:issueDispatchInstructionResponse xmlns:sm="http://sm.westernpower.com.au/operations.dispatchinstructions.issue.v1">
      <tns:issueDispatchInstructionResponse xmlns:tns="http://sm.westernpower.com.au/operations.dispatchinstructions.v1">
        <tns:response>
          <tns:responseCode>0</tns:responseCode>
          <tns:responseCodeDesc>Success</tns:responseCodeDesc>
          <tns:receivedDateTime>2013-03-12T09:20:30.000+08:00</tns:receivedDateTime>
          <tns:executionTime>0.025 </tns:executionTime>
        </tns:response>
      </tns:issueDispatchInstructionResponse>
    </sm:issueDispatchInstructionResponse>
  </soapenv:Body>
</soapenv:Envelope>
```

5.6.2 Dispatch Instruction Acknowledgment

HTTP/1.1 200 OK

Content-Type: text/xml; charset=UTF-8

Content-Length: 227

```
<?xml version="1.0" encoding="UTF-8"?>
```

```
<Values version="2.0">
```

```
  <record name="TN_parms" javaclass="com.wm.util.Values">
```

```
    <value name="$contentType">text/xml</value>
```

```
    <null name="$contentEncoding"/>
```

```
  </record>
```

```
</Values>
```

6 B2B Gateway Interaction

6.1 System Management

System Management's B2B Gateway provides a generic interface for the receipt of Business documents from trading partners. The HTTP protocol is used to POST the Business document whereby rules within the gateway determine what to do with the document. This interface does not use SOAP.

6.2 Market Participant

Should a Market Participant offer a B2B Gateway, System Management can deliver the Dispatch Instruction message to that interface in place of the Web Service described.

6.3 Usage

6.3.1 Endpoint

The end point, excepting host and port, for delivery of documents to the gateways is:

- <https://mpb2b.sm.westernpower.com.au:8080/invoke/wm.tn:receive>

6.3.2 WAD

The attached WAD is used as a means to communicate the mechanism for interacting with the B2B Gateway, however is not required to develop services to that end. It does not specify the composition of the message to be transmitted.

The same effect is achieved by posting a specified XML document as the body of a HTTP POST request to specified URL indicating in the header that the content-type is text/xml

6.3.2.1 Example DI Acknowledgement Built from WAD

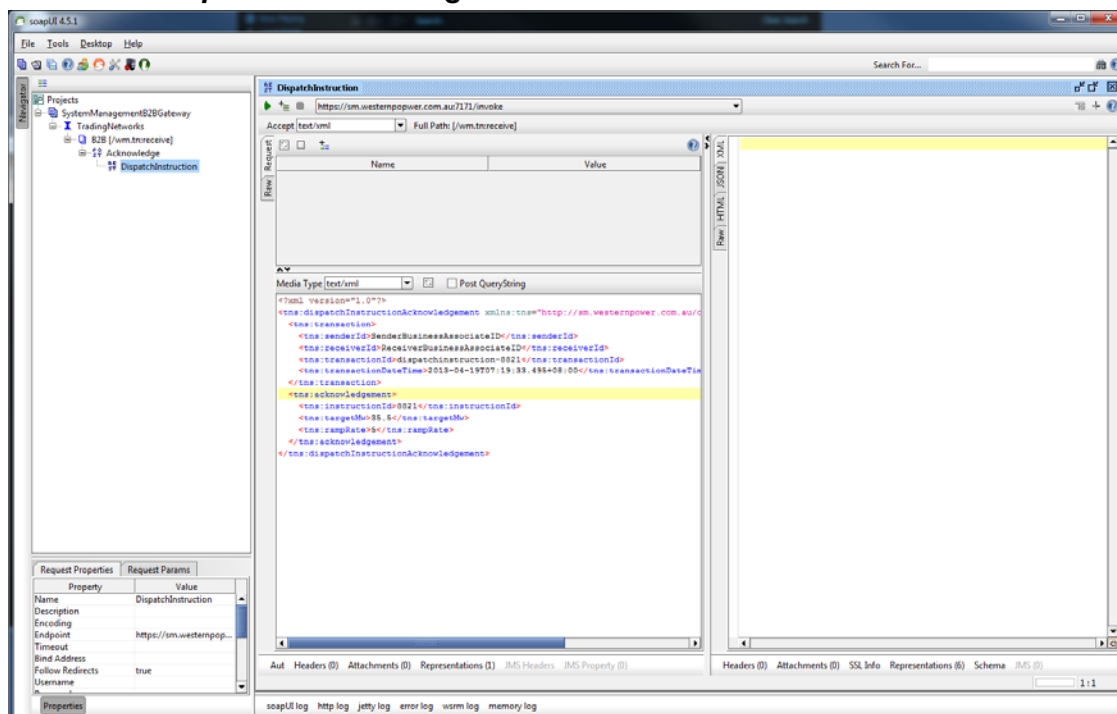

6.3.3 Message Exchange

The message exchange pattern remains the same irrespective of the communication methods used. The use of a B2B Gateway simplifies the interfaces and places greater emphasis on the Business Process and the process data easing the establishment of future exchanges between parties.

6.3.3.1 SOAP and Gateway

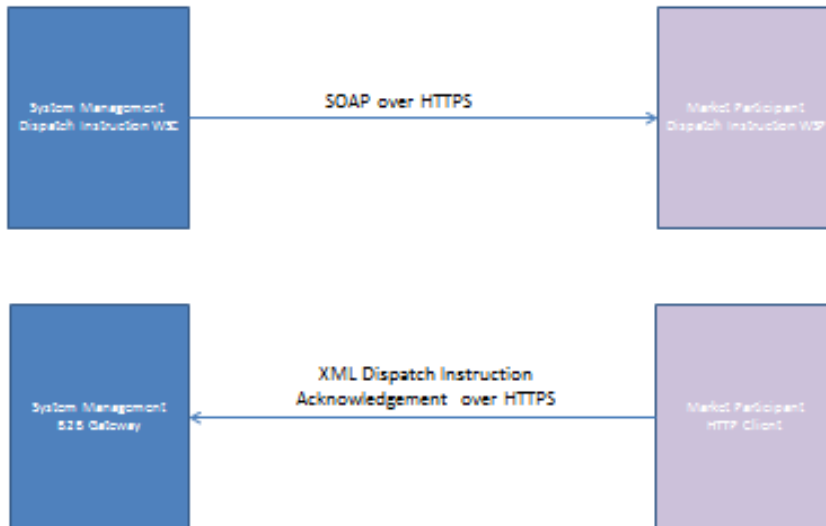

6.3.3.2 Gateway and Gateway

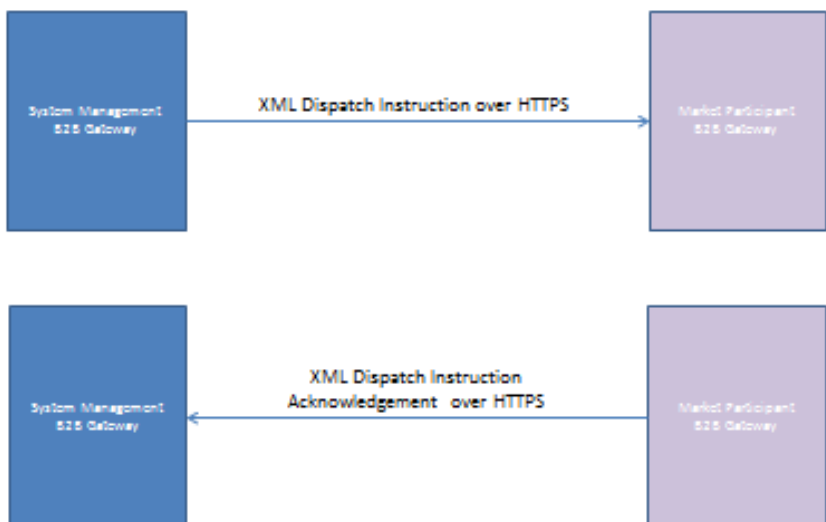

7 Service Contract Files

7.1 Dispatch Instruction XSD

Available from the following URL:

<http://www.westernpower.com.au/documents/retailersgenerators/systemManagement/b2b/DispatchInstruction-v1.1.xsd>

7.2 Dispatch Instruction WSDL

Available from the following URL:

<http://www.westernpower.com.au/documents/retailersgenerators/systemManagement/b2b/DispatchInstructionMPv1.0.wsdl>

7.3 B2B Gateway WADL

Available from the following URL:

<http://www.westernpower.com.au/documents/retailersgenerators/systemManagement/b2b/SystemManagementB2B.wadl>