

Schema Release Notes
AseXML Schema Working Group
Release r14

Document History

Version	Date	Authors	Comments
1.0	07/04/2004	Bhawna Kapoor	Initial draft

Contents

Schema Release Notes.....	1
AseXML Schema Working Group	1
Release r14.....	1
Document History.....	2
Contents.....	3
1. Introduction	4
2. Change Requests	4
3. Schema Manifest	4
4. File Change Summary	5
3.1 Acknowledgements	5
3.2 aseXML.....	5
3.3 BAR	5
3.4 BulkDataTool.....	5
3.5 CATSReport.....	5
3.6 CATSTableReplication	5
3.7 ClientInformation.....	5
3.8 Common	5
3.9 CustomerDetails	7
3.10 CustomerTransfer.....	11
3.11 Electricity.....	11
3.12 Enumerations	17
3.13 Events	17
3.14 Faults.....	17
3.15 Gas	17
3.16 Header.....	18
3.17 MDMTReport	18
3.18 MeterDataManagement	18
3.19 NetworkBilling	19
3.20 NMIDataAccess.....	19
3.21 NOSBooking	21
3.22 NOSCommon	22
3.23 NOSEquipment	23
3.24 Reports.....	23
3.25 ServiceOrder	23
3.26 TableReplication	23
3.27 Transactions.....	23
5. Disclaimer	24

1. Introduction

Version r14 of the schema is developed from r13. This document identifies the changes made to the schema for this release.

2. Change Requests

The following ASWG Change Requests have been included in this schema release:

CR#	Description
16	Modified the existing schema to support National B2B processes for electricity.
17	Updated the schema to include additional Network Outage Scheduler (NOS) transactions.

3. Schema Manifest

The table below shows the schema files included in this release. Files that have been added, removed or modified for this release are marked.

File names	Added	Removed	Modified
Acknowledgements_r9.xsd			
aseXML_r14.xsd			X
BAR_r13			
BulkDataTool_r9			
CATSReports_r9.xsd			
CATSTableReplication_r12.xsd			
ClientInformation_r13.xsd			
Common_r14.xsd			X
CustomerDetails_r14.xsd			X
CustomerTransfer_r12.xsd			
Electricity_r14.xsd			X
Enumerations.xsd			
Events_r14.xsd			X
Faults_r14.xsd			X
Gas_r14.xsd			X
Header_r14.xsd			X
MDMTRReport_r10.xsd			
MeterDataManagement_r14.xsd			X
NetworkBilling_r13.xsd			
NMIDataAccess_r14.xsd			X
NOSBooking_r14			X
NOSCommon_r14	X		
NOSEquipment_r14			X
Reports_r10.xsd			
ServiceOrder_r14.xsd			X
TableReplication_r10.xsd			
Transactions_r14			X
No of files added	1		
No of files removed		0	
No of files modified			14
Total No of files			27

4. File Change Summary

The section identifies and lists any changes between the various versions of the schema files and highlights any issues.

3.1 *Acknowledgements*

- No change

3.2 *aseXML*

- Changed aseXML namespace to aseXML:r14
- Changed names of included files affected by r14
- Added an include statement for NOSCommon_r14

3.3 *BAR*

- No change

3.4 *BulkDataTool*

- No change

3.5 *CATSReport*

- No change

3.6 *CATSTableReplication*

- No change

3.7 *ClientInformation*

- No change

3.8 *Common*

- Added following new simpleType elements:
 - a) ShortUniqueIdentifier defined as

```
<xsd:restriction base="xsd:string">
  <xsd:minLength value="1"/>
  <xsd:maxLength value="15"/>
</xsd:restriction>
```
 - b) AccessDetail defined as

```
<xsd:restriction base="xsd:string">
  <xsd:maxLength value="160"/>
</xsd:restriction>
```
 - c) HazardDescription defined as

```
<xsd:restriction base="xsd:string">
  <xsd:maxLength value="80"/>
</xsd:restriction>
```
- Added a new enumerated list MethodSent defined as

```
<xsd:enumeration value="Faxed"/>
<xsd:enumeration value="OnSite"/>
```
- Moved IndexInvestigationCode from Gas to Common and redefined as

```
<xsd:enumeration value="Confirm Zero Reading"/>
<xsd:enumeration value="Customer Away"/>
<xsd:enumeration value="Customer Query"/>
<xsd:enumeration value="Customer Read"/>
<xsd:enumeration value="Vacant Site"/>
```

```

<xsd:enumeration value="High Account"/>
<xsd:enumeration value="High Reading"/>
<xsd:enumeration value="Incomplete Data"/>
<xsd:enumeration value="Low Reading"/>
<xsd:enumeration value="Require Actual Reading"/>
<xsd:enumeration value="Require Later Version"/>
<xsd:enumeration value="Zero Consumption"/>
<xsd:enumeration value="Other"/>
    
```

- Moved complexType SafetyCertificateID from Electricity to Common and defined as extension of the ShortUniquelIdentifier as follows:

SafetyCertificateID

Attributes		Identity constraints	
Name		Type	
methodSent		MethodSent	

- Modified the complexType AppointmentDetails:
 - Removed the complexType Alternative.
 - added an optional element ScheduledDate.

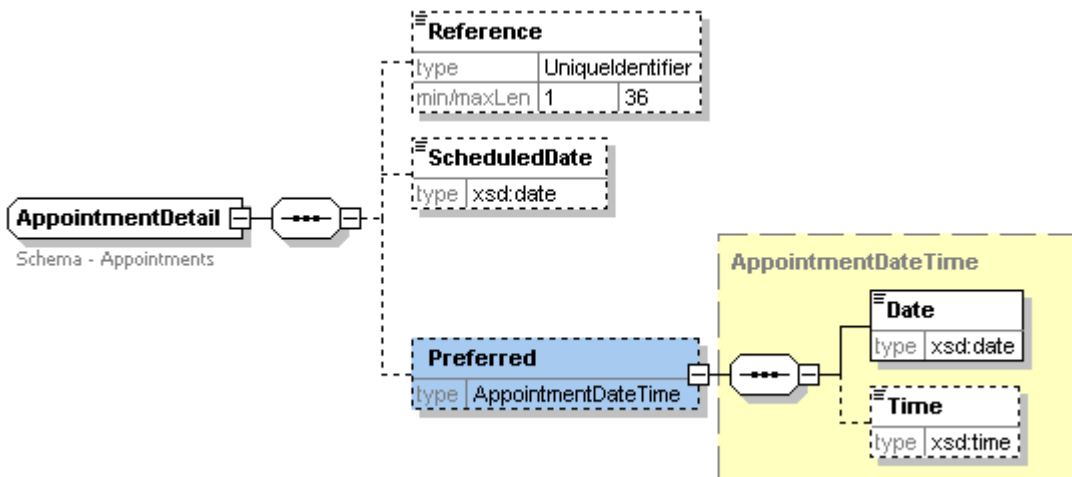

- Modified the complexType ServicePoint:
 - Added an optional element HazardDescription.

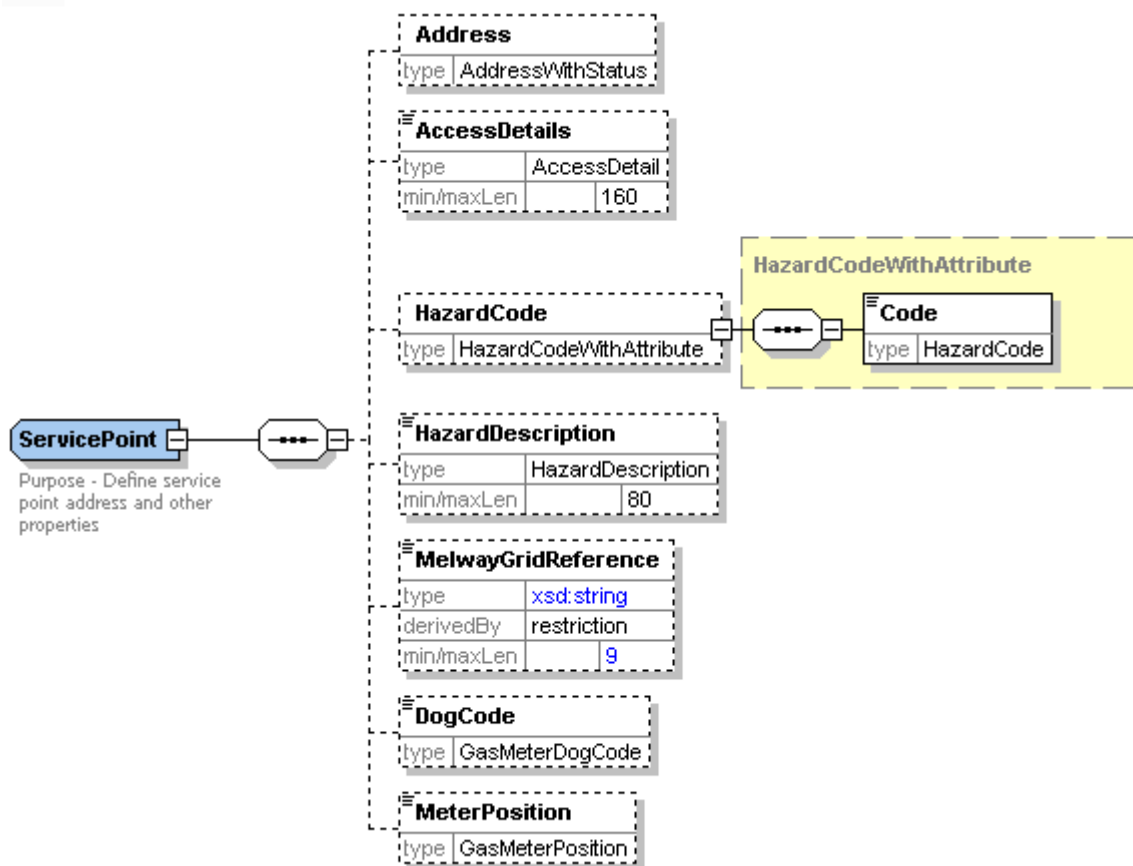

3.9 CustomerDetails

- Added new enumerated lists as follows:
 - a) CustomerType defined as:
 - <xsd:enumeration value="Industrial"/>
 - <xsd:enumeration value="Commercial"/>
 - <xsd:enumeration value="Residential"/>
 - <xsd:enumeration value="Farm"/>
 - <xsd:enumeration value="Lighting"/>
 - b) SensitiveLoadType defined as:
 - <xsd:enumeration value="Life Support"/>
 - <xsd:enumeration value="Sensitive Load"/>
 - <xsd:enumeration value="None"/>
 - c) MovementType defined as:
 - <xsd:enumeration value="Move Out"/>
 - <xsd:enumeration value="Move In"/>
 - <xsd:enumeration value="Update"/>
 - <xsd:enumeration value="Reconciliation"/>
 - d) RequestReason defined as:
 - <xsd:enumeration value="Returned Mail"/>
 - <xsd:enumeration value="Missing Customer Details"/>
 - <xsd:enumeration value="Confirm Sensitive Load"/>
 - <xsd:enumeration value="Other"/>
 - e) RebateType defined as:
 - <xsd:enumeration value="Pension Card"/>
 - <xsd:enumeration value="Health Care Card"/>
 - <xsd:enumeration value="Health Benefit Card"/>
 - <xsd:enumeration value="Veteran Affairs Card"/>

- Defined a new complex type ConcessionCard as follows:

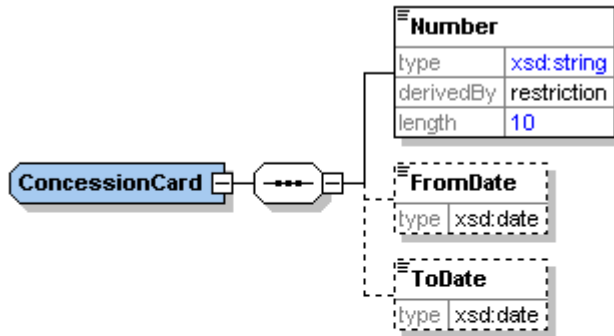

Attributes		Identity constraints	
Name	Type		
rebateType	RebateType		

- Updated the complex type CustomerDetail as follows:
 - Removed SpecialCondition.
 - Added optional elements SensitiveLoad, MovementType, LastModifiedDateTime, ConcessionCard.

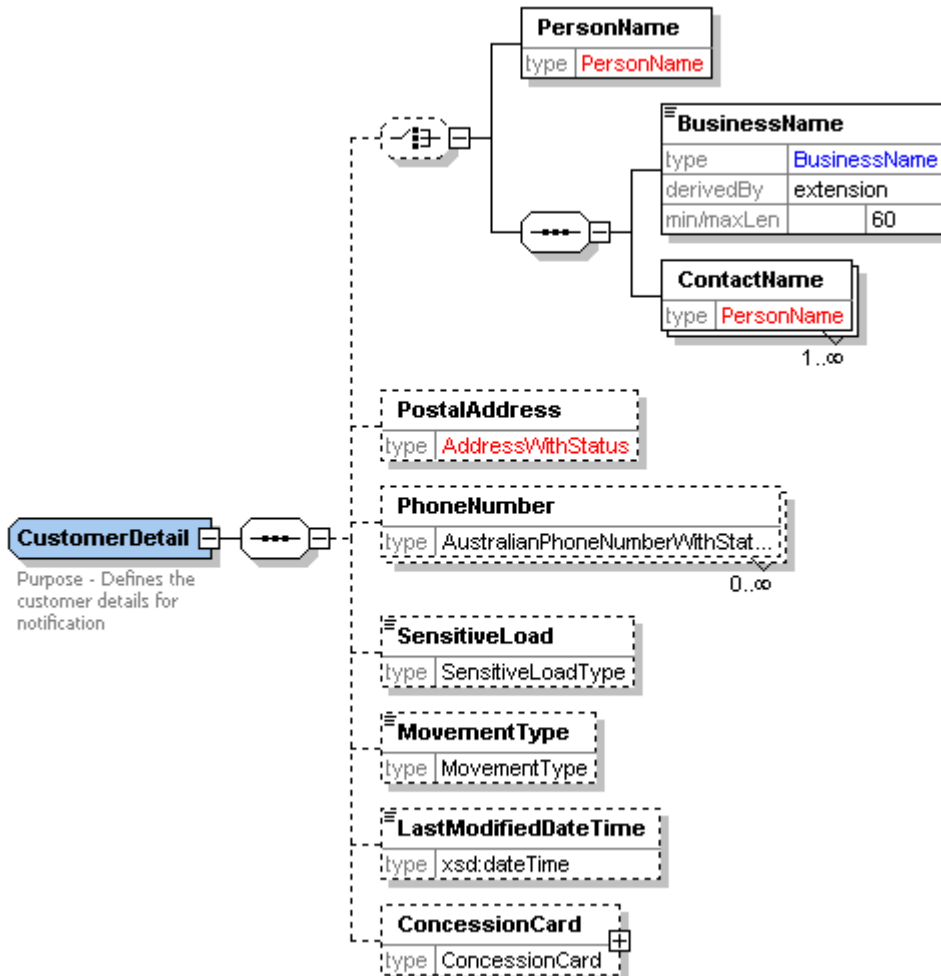

- Deleted complex type CustomerComplaintNotification. *This transaction type was not used in VicGas.*
- Added complex type CustomerDetailsRequest.

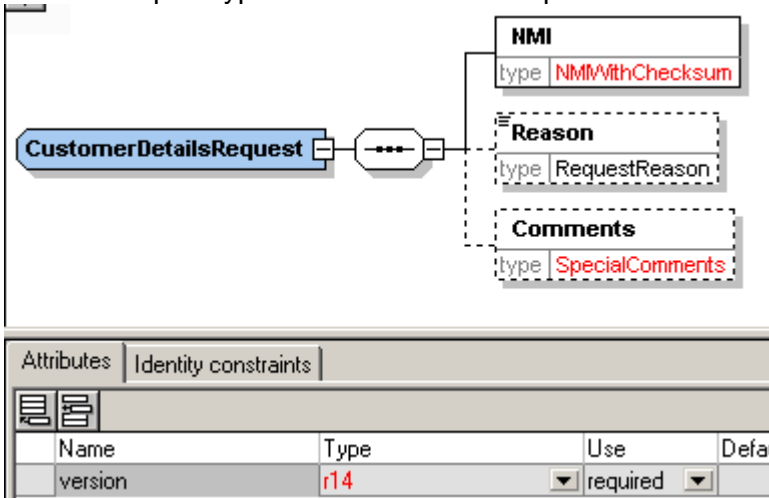

- Updated version attribute of the complex type CustomerDetailsNotification.
- CustomerDetailsNotification/Customer is changed to support only single Customer data instead of multiple Customers.

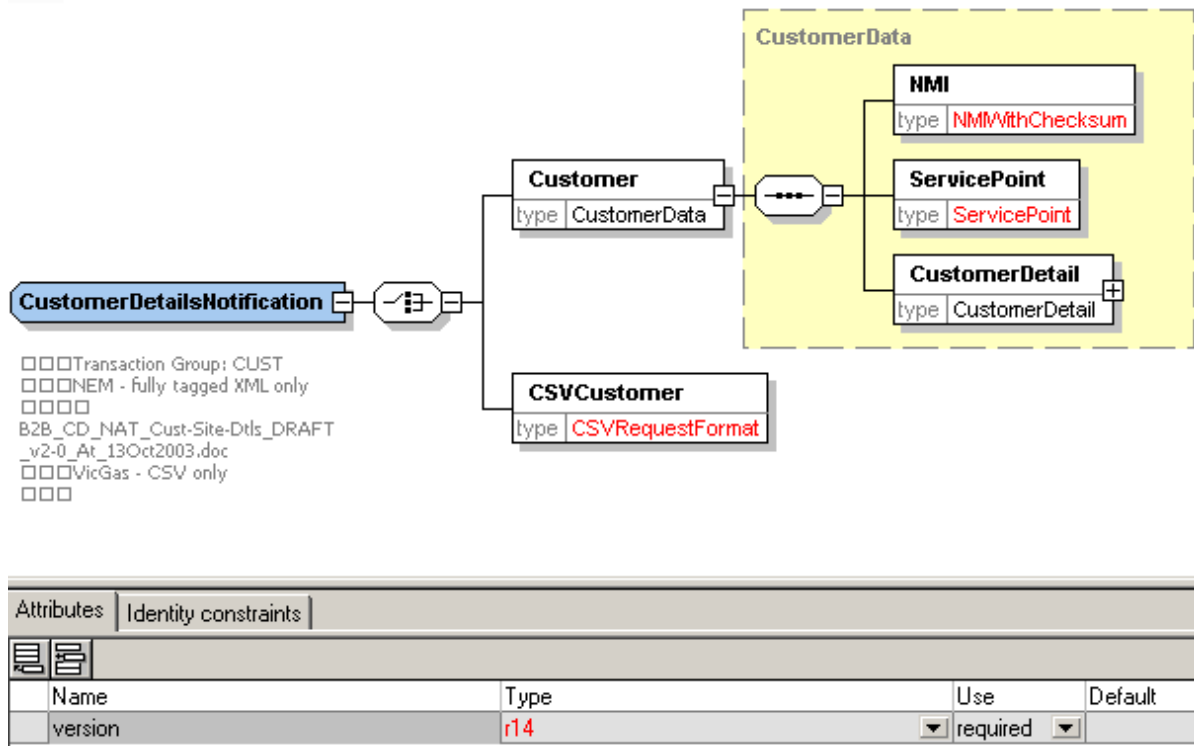

- Deleted complex type CustomerDisconnectionNotification. *This transaction type was not used in VicGas.*
- Added complex type SiteAddressDetails

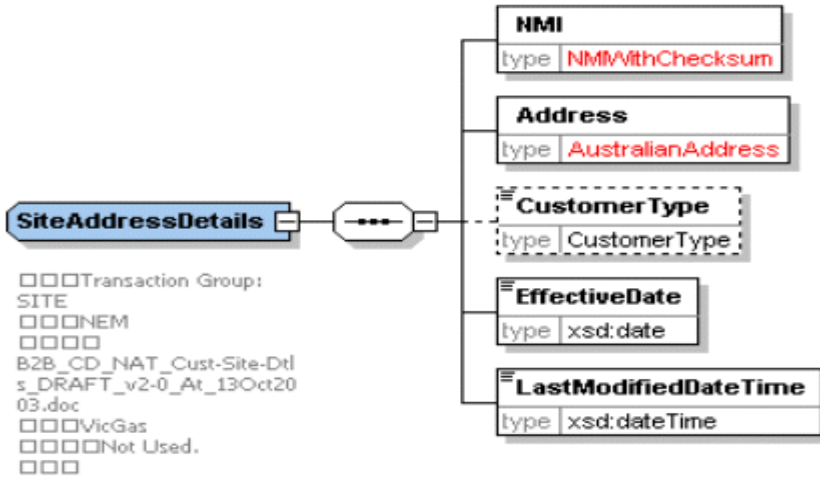

- Added complex type SiteAccessDetails

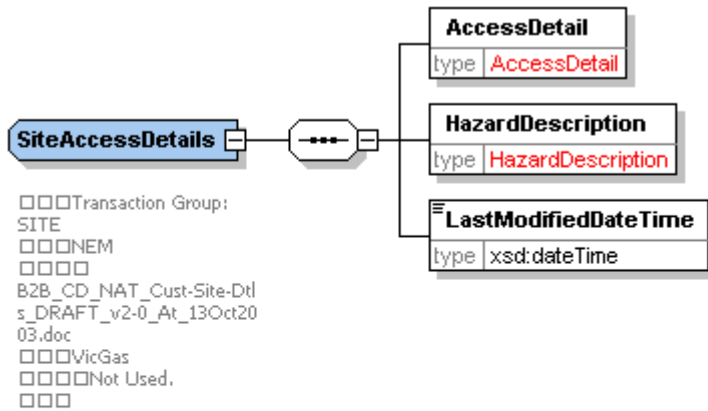

Attributes		Identity constraints	
Name	Type	Use	
version	r14	required	

- Updated complex type AmendMeterRouteDetails as follows:
 - Added an optional SiteAddressDetails element.
 - Updated the version attribute to r14.

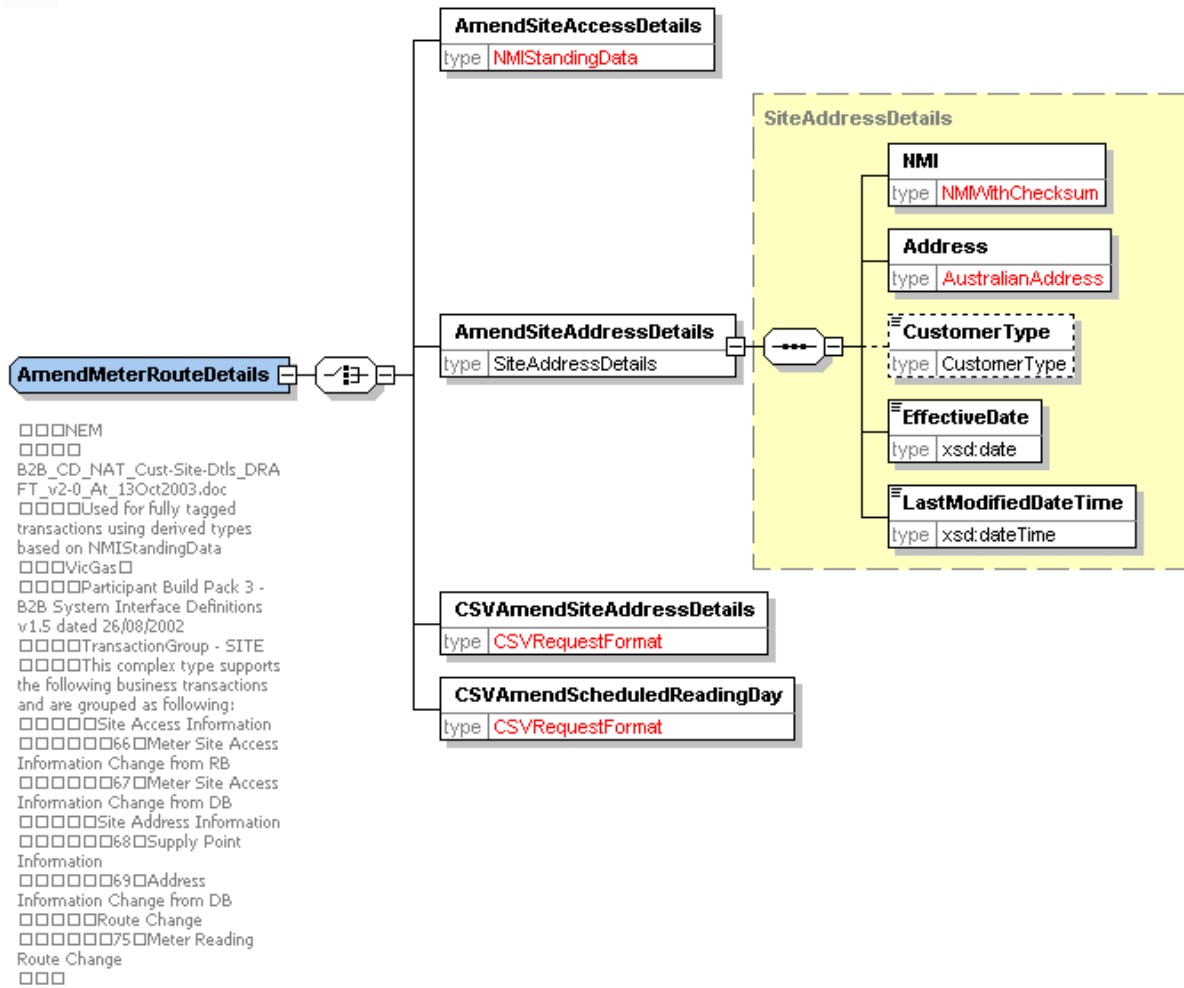

Attributes		Identity constraints	
Name	Type	Use	Default
version	r14	required	

3.10 CustomerTransfer

- No change.

3.11 Electricity

- Added simpleType DirectionIndicator as enumerated list of:
 - `<xsd:enumeration value="Import"/>`
 - `<xsd:enumeration value="Export"/>`
- Added simpleType MeteringType as enumerated list of:
 - `<xsd:enumeration value="Flat Rate"/>`
 - `<xsd:enumeration value="Time Of Use"/>`
 - `<xsd:enumeration value="CT Meter"/>`
 - `<xsd:enumeration value="Other"/>`
- Reduced maximum length of LicenseNumber from 30 to 20 characters.

- Updated complexType License as follows:
 - Added optional BusinessName, DocumentReference and AttendanceRequired elements.

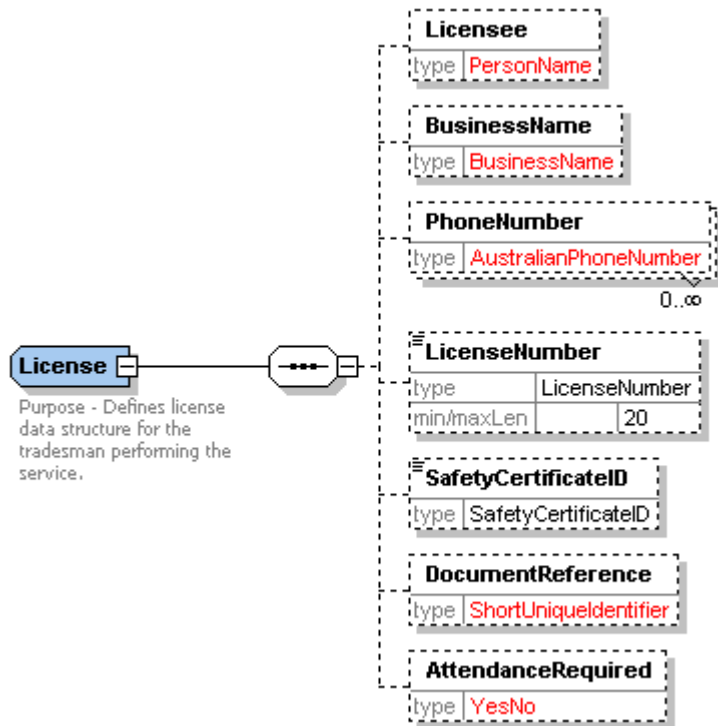

- Redefined simpleType ServiceOrderType

```

            <xsd:enumeration value="DEENERGISE"/>
            <xsd:enumeration value="REENERGISE"/>
            <xsd:enumeration value="SPECIALRD"/>
            <xsd:enumeration value="NEWCONNECT"/>
            <xsd:enumeration value="MTRADDALTS"/>
            <xsd:enumeration value="MTRRECNFIG"/>
            <xsd:enumeration value="MTRINSPECT"/>
            <xsd:enumeration value="SUPABOLISH"/>
            <xsd:enumeration value="MISC"/>
            <xsd:enumeration value="ALLOCNMI"/>
            
```
- Redefined simpleType ServiceOrderSubType

```

            <xsd:enumeration value="After Hours"/>
            <xsd:enumeration value="After Disconnection"/>
            <xsd:enumeration value="Sticker Removal"/>
            <xsd:enumeration value="Pillar-Box Pit Or Pole-Top"/>
            <xsd:enumeration value="Pillar-Box Pit Or Pole-Top (Non-Payment)"/>
            <xsd:enumeration value="Sticker"/>
            <xsd:enumeration value="Remove Fuse"/>
            <xsd:enumeration value="Remove Fuse (Non-Payment)"/>
            <xsd:enumeration value="Install Hot Water"/>
            <xsd:enumeration value="Move Meter"/>
            <xsd:enumeration value="Install Meter"/>
            <xsd:enumeration value="Remove Meter"/>
            <xsd:enumeration value="Exchange Meter"/>
            <xsd:enumeration value="Status Change Read"/>
            <xsd:enumeration value="Check Read"/>
            <xsd:enumeration value="Change Offpeak"/>
            <xsd:enumeration value="Change Tariff"/>
            <xsd:enumeration value="Tamper"/>
            
```

```
<xsd:enumeration value="Inspect"/>
<xsd:enumeration value="Meter Test"/>
```

- Redefined simpleType SupplyPhase

```
<xsd:enumeration value="1-phase"/>
<xsd:enumeration value="2-phase"/>
<xsd:enumeration value="3-phase"/>
<xsd:enumeration value="Other Multi-phase"/>
```
- Redefined simpleType InstallationType

```
<xsd:enumeration value="Underground"/>
<xsd:enumeration value="Overhead"/>
<xsd:enumeration value="Underground To Overhead Mains"/>
<xsd:enumeration value="Overhead To Underground Mains"/>
```
- Redefined simpleType SORDResponseCode

```
<xsd:enumeration value="Unable To Access"/>
<xsd:enumeration value="No Supply"/>
<xsd:enumeration value="Unsafe"/>
<xsd:enumeration value="Sensitive Load"/>
<xsd:enumeration value="Retailer Cancellation"/>
<xsd:enumeration value="LNSP Cancellation"/>
<xsd:enumeration value="Metering Problem"/>
<xsd:enumeration value="Reading Problem"/>
<xsd:enumeration value="Other"/>
<xsd:enumeration value="Customer Prevented"/>
<xsd:enumeration value="Customer Onsite"/>
```
- Updated the version attribute of the complexType ElectricityServiceOrderType to r14.
- Updated complexType ElectricityServiceOrderDetails as follows:
 - a) Added optional MeteringType, OffPeakRequirements, MaximumDemand and NMISstandingData elements.
 - b) Updated the version attribute to r14.

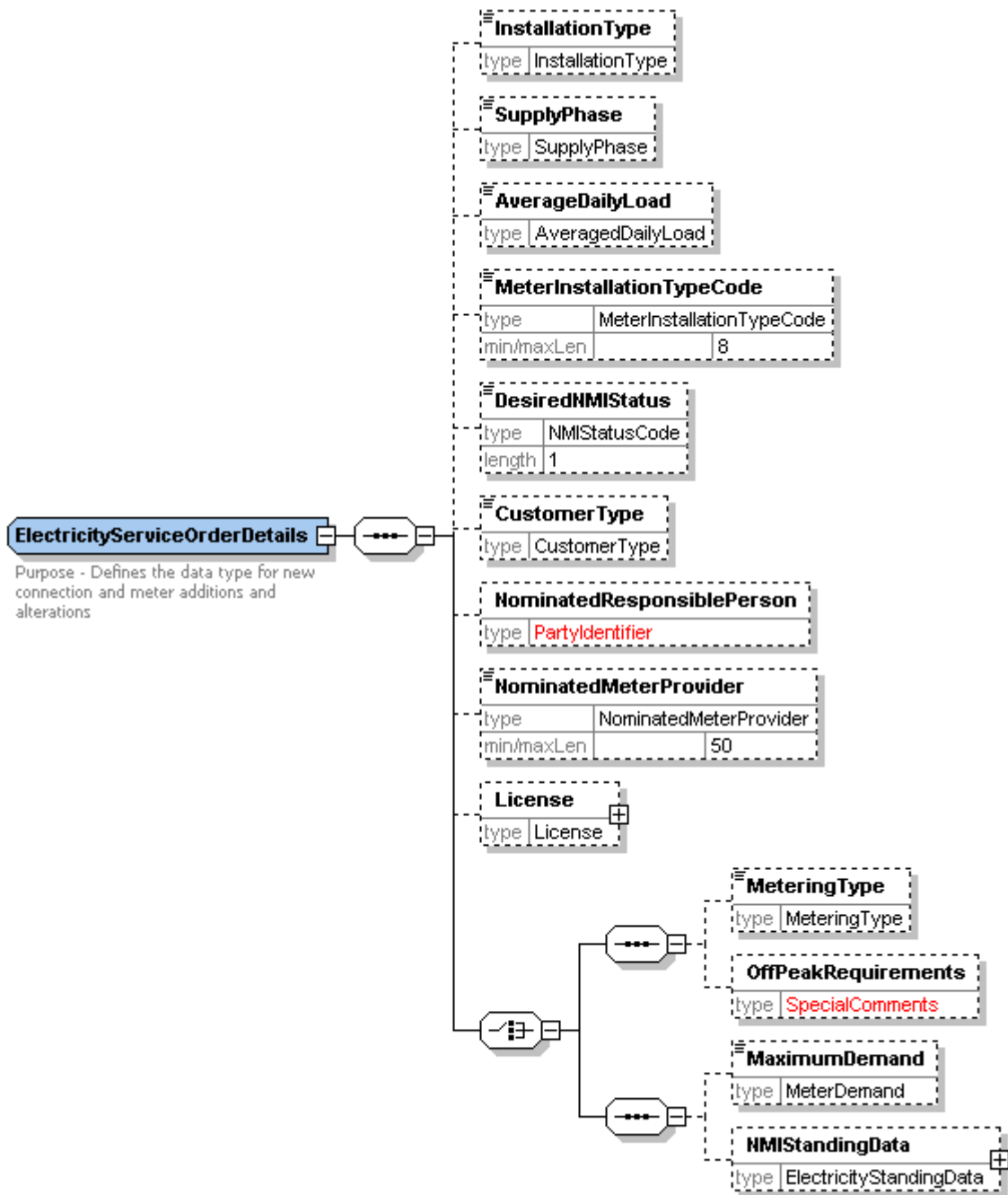

- Updated the complexType ElectricityServiceOrderNotificationData as follows:
 - ActualDate and ActualTime replaced with ActualDateTime.
 - Updated the version attribute to r14.

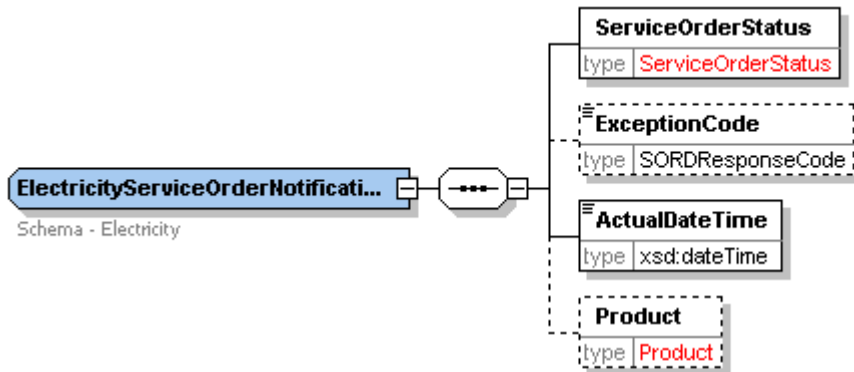

Attributes		Identity constraints	
Name	Type	Use	Default
version	r14	optional	

- Deleted complexTypes: SpecialReadType, SpecialReadData, NewConnection.
- Defined new complexType ElectricityMeterReadData

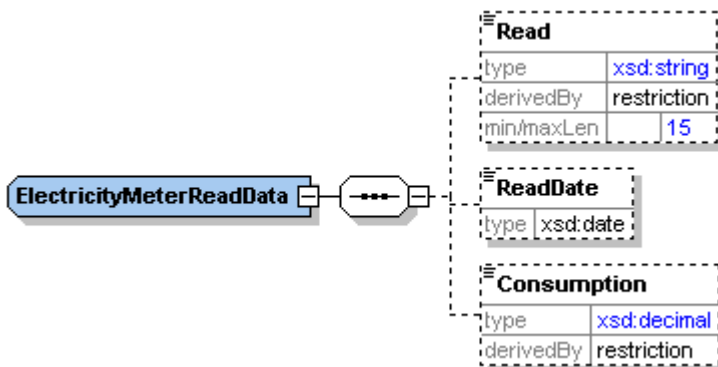

- Defined new complexType ElectricityMeterProvideRequestData

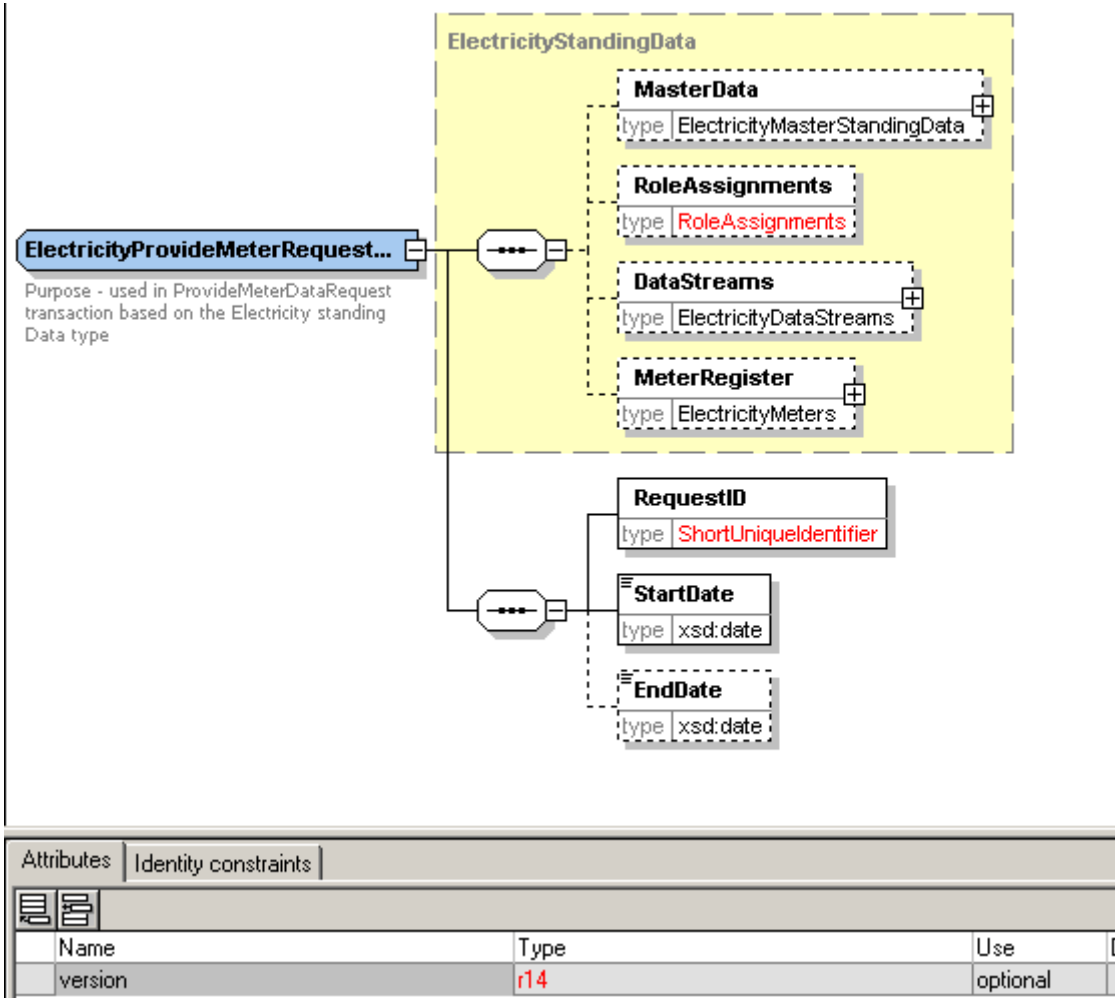

- Defined new complexType ElectricityVerifyMeterRequestData

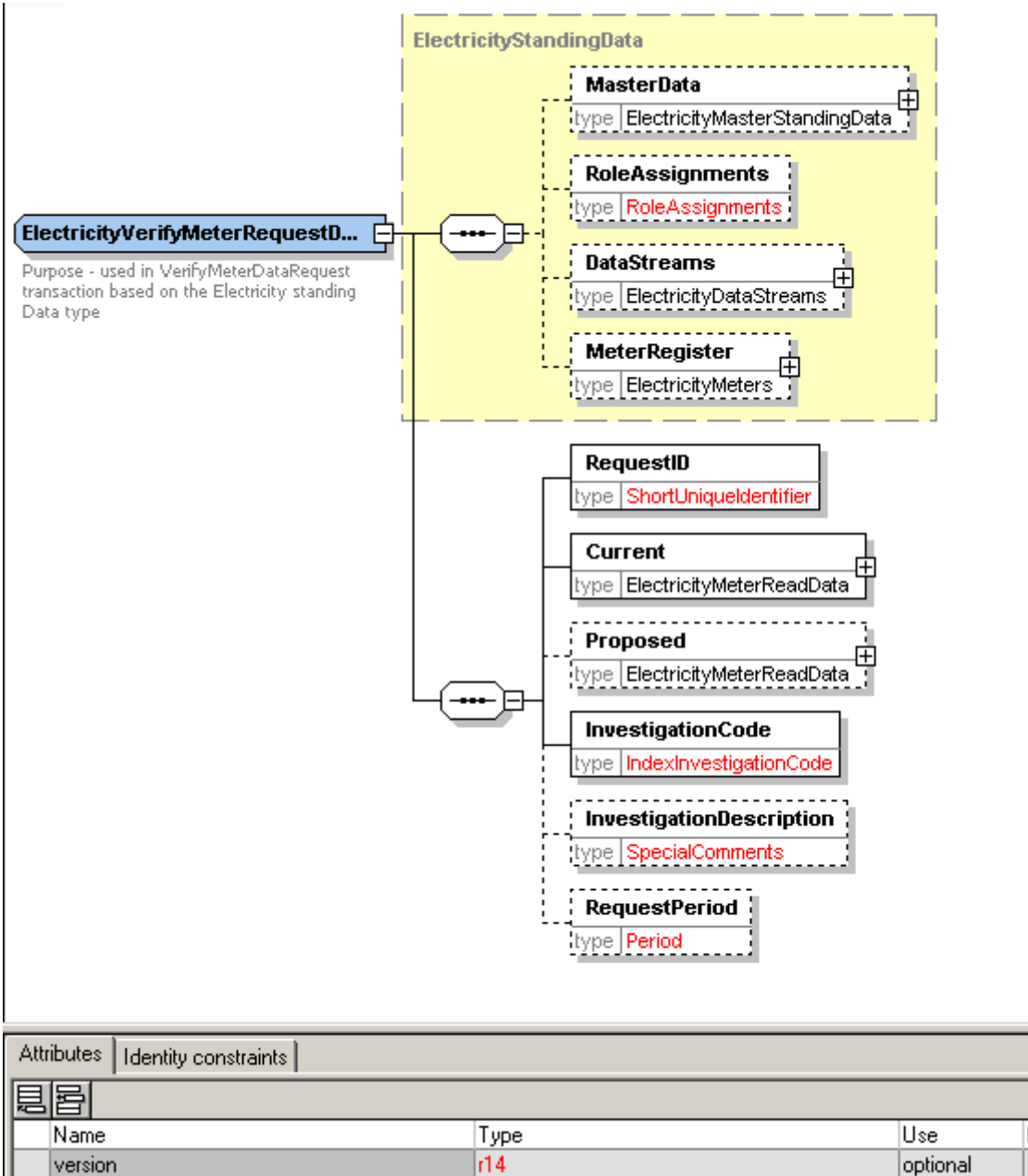

- Moved SafetyCertificateID to Common.

3.12 Enumerations

- No change

3.13 Events

- Added release identifier for r14.

3.14 Faults

- Updated version attributes for complexType FaultNotification and FaultOutageAdvice to r14.

3.15 Gas

- Moved simpleType IndexInvestigationCode to Common.
- Updated version attribute of GasStandingData to r14.
- Modified the base type for the GasMeterVerifyRequestData and updated the version attribute.

3.16 Header

- Added new Transaction Group NMIF.

3.17 MDMTRReport

- No change.

3.18 MeterDataManagement

- Changed the base type for MeterDataVerifyRequest.

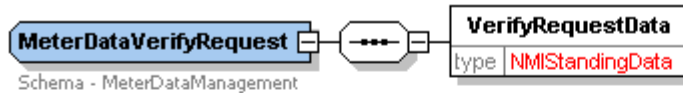

Attributes		Identity constraints	
Name	version	Type	r9
		Use	required

- Updated the complexType MeterDataMissingNotification as follows:
 - Added MissingMeterData element.
 - Updated the version attribute to r14.

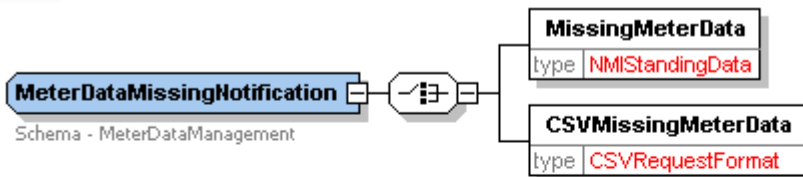

Attributes		Identity constraints	
Name	version	Type	r14
		Use	required

- Updated the complexType MeterDataNotification as follows:
 - Added optional RecordCount, RequestID, BlockNumber and LastBlockFlag elements.
 - Updated the version attribute to r14.

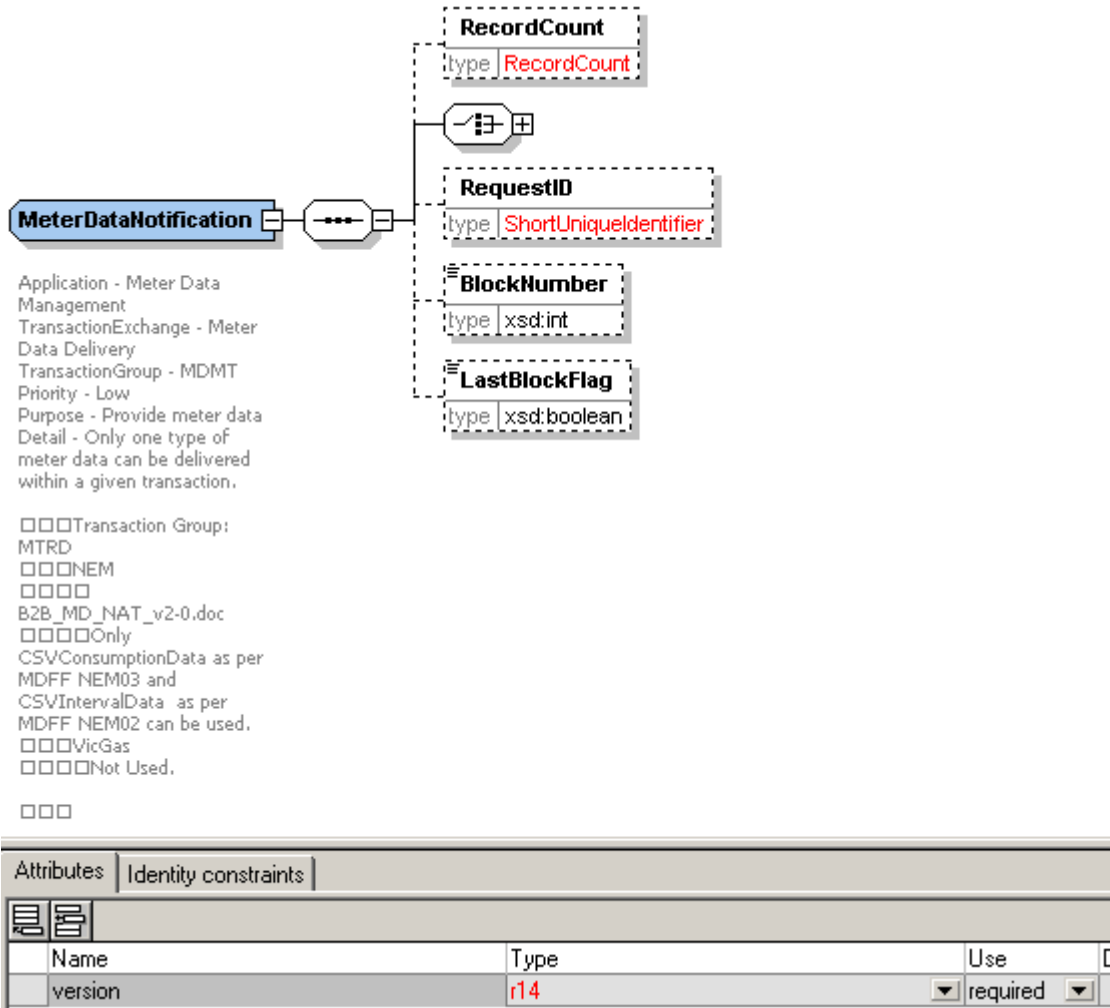

Note: The choice options have not changed and are not shown in this diagram.

3.19 NetworkBilling

- No change.

3.20 NMIDataAccess

- Updated the complexType NMIDiscoveryRequest as follows:
 - a) Added optional RequestID, Retailer, CustomerName and BusinessName elements.
 - b) Updated the version to r14.

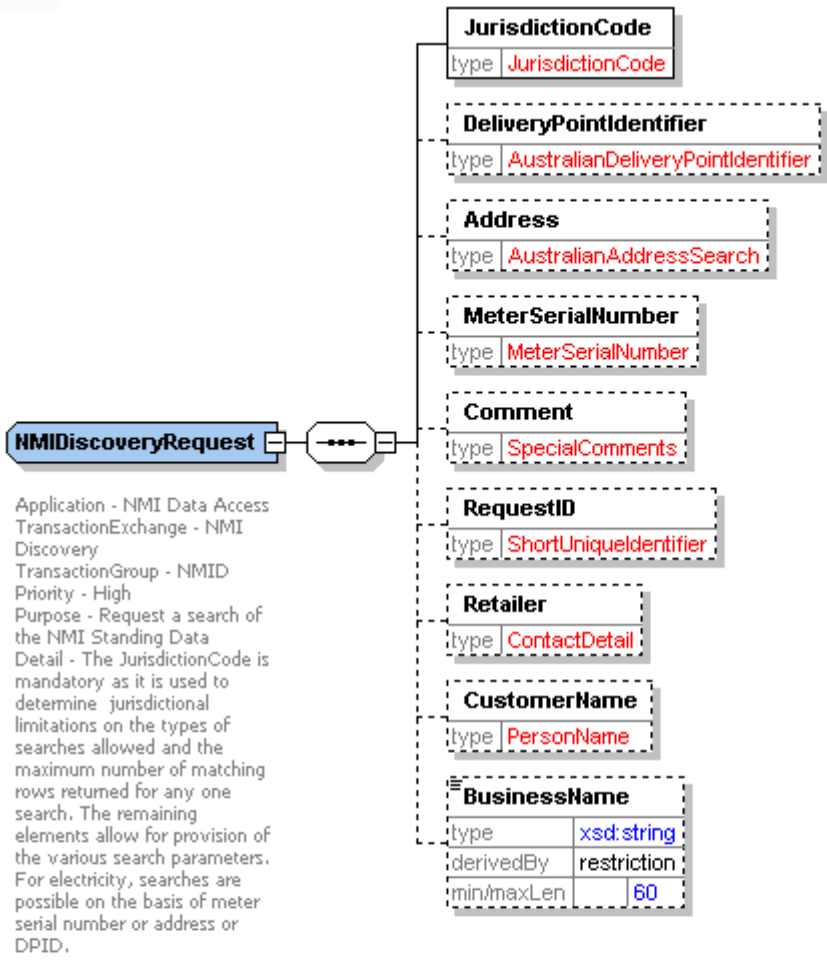

Attributes		Identity constraints	
Name	Type	Use	
version	r14	required	

- Updated the complexType NMIDiscoveryResponse as follows:
 - Added optional RequestID and Comment elements.
 - Updated the version attribute to r14.

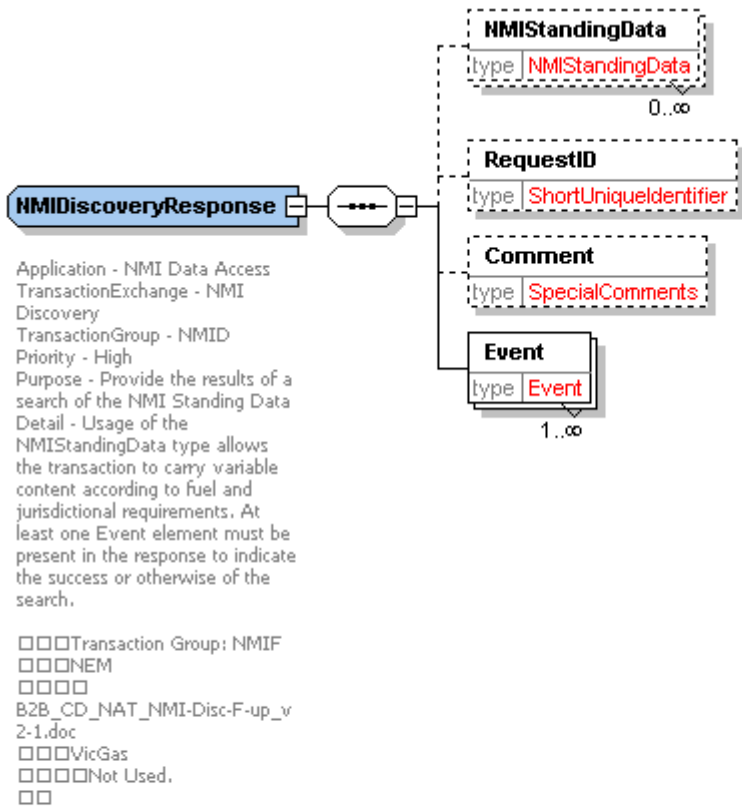

Attributes		Identity constraints	
Name	Type	Use	Cardinality
version	r14	required	1

3.21 NOSBooking

- Added derivedTypes OutageResponseType, CompanyNoteResponseType, BookingElementResponseType, BookingResponseType.
- Added transaction NOSBookingResponse.

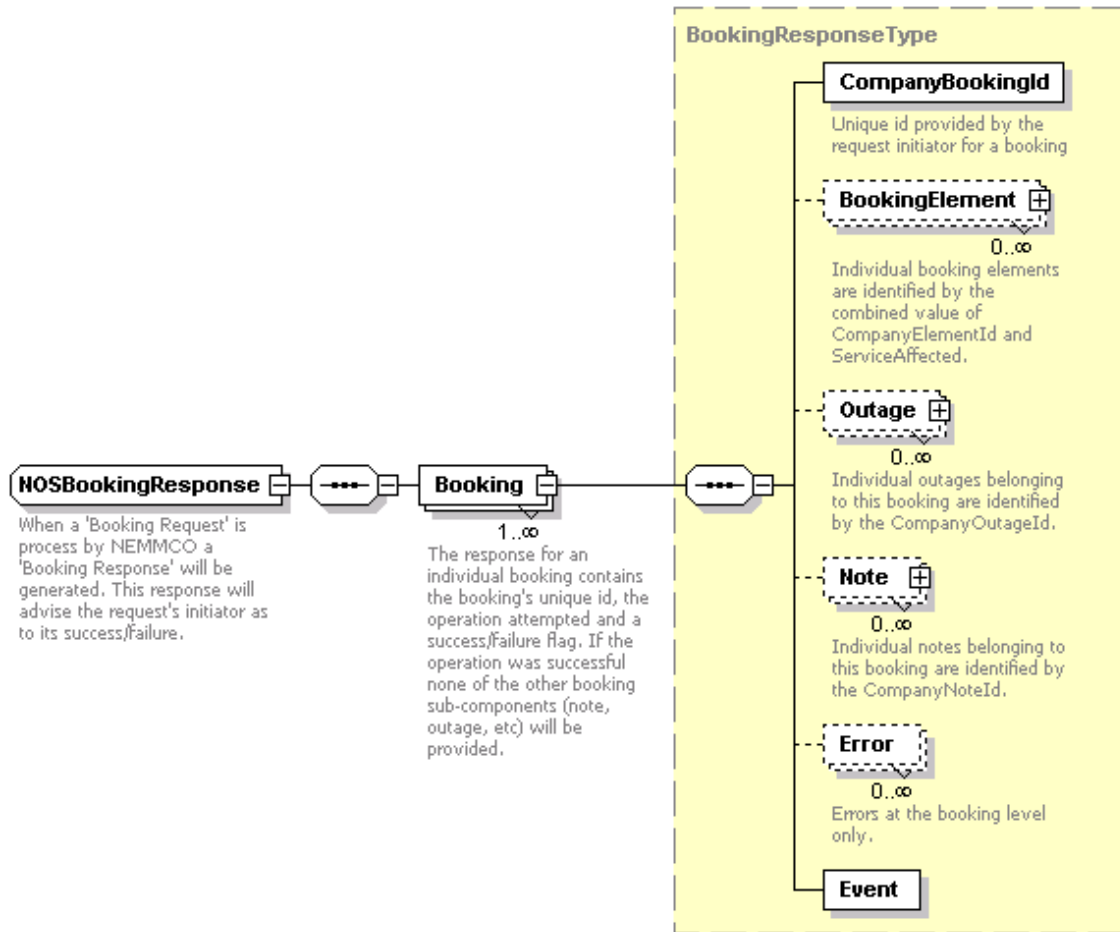

- Updated the element BookingElementType as follows:
 - a) Set the minLength to 1 in ServiceAffectedDetail.
- Moved the following elements to NOSCommon:
 - CompanyElementIdType, CompanyOutageIdType, CompanyBookingIdType, CompanyNoteIdType, CompanyRefCodeType, EnumResubmitReasonType and NoteType.

3.22 NOSCommon

- Updated the element NoteType as follows:
 - a) Set the minLength to 1 in PlainText and FileName.
- Set the minLength to 1 for CompanyElementIdType, CompanyOutageIdType, CompanyBookingIdType, CompanyNoteIdType and CompanyRefCodeType.
- Added complexType NOSErrorType.

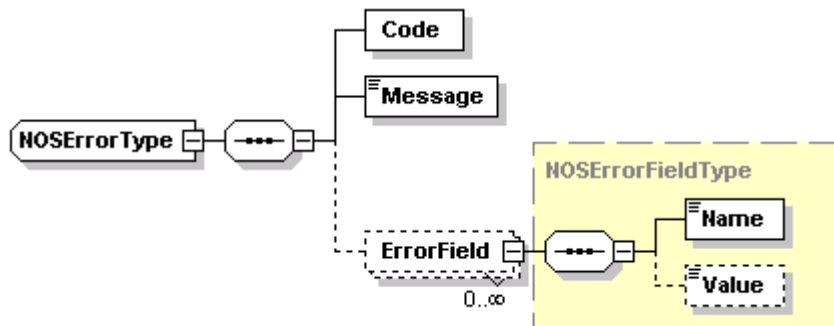

- Updated the enumerated list EnumResubmitReasonType.

```
<xsd:simpleType name="EnumResubmitReasonType">
<xsd:annotation>
```

```

        <xsd:documentation>Enumeration of possible reason for resubmission or withdrawal of an
outage</xsd:documentation>
    </xsd:annotation>
    <xsd:restriction base="xsd:string">
        <xsd:maxLength value="40"/>
        <xsd:whiteSpace value="collapse"/>
        <xsd:enumeration value="Not Supplied"/>
        <xsd:enumeration value="Information Update"/>
        <xsd:enumeration value="Optimising Availability"/>
        <xsd:enumeration value="Environ Hazards"/>
        <xsd:enumeration value="Resource Problems"/>
        <xsd:enumeration value="NEMMCO Request"/>
        <xsd:enumeration value="System Incident"/>
        <xsd:enumeration value="Weather"/>
    </xsd:restriction>
</xsd:simpleType>

```

3.23 NOSEquipment

- Added Derived type EquipmentResponseType.
- Added complexType NOSEquipmentResponse.

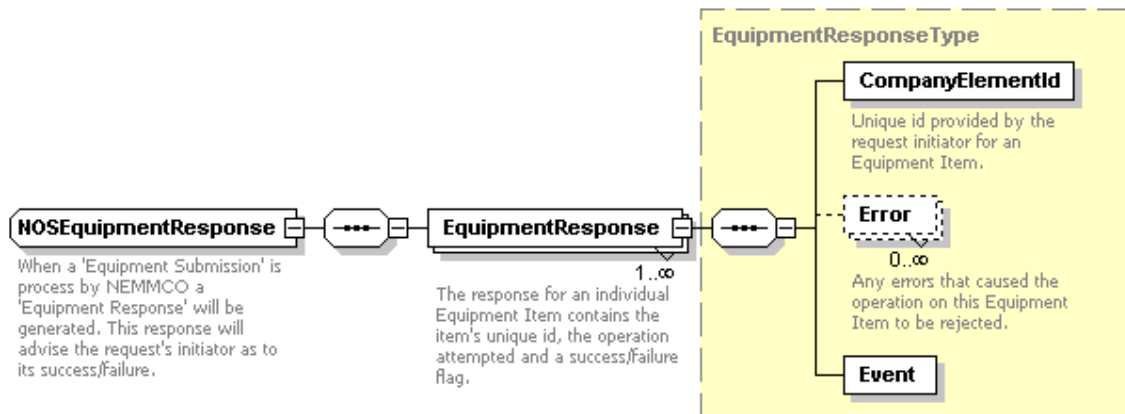

- Set the minLength to 1 for elements EquipmentBaseType.CompanyElementName, NOSEquipmentType.Designation.
- Set the minLength to 1 for attribute NOSEquipmentSubmission.subject.

3.24 Reports

- No change

3.25 ServiceOrder

- Modified the ResponseType to include:

```
<xsd:enumeration value=" Appointment"/>
```
- Updated the version attribute of ServiceOrderRequest and ServiceOrderNotification.

3.26 TableReplication

- No change.

3.27 Transactions

- Added following new transactions:
 - a) CustomerDetailsRequest.

- b) NOSBookingResponse.
- c) NOSEquipmentResponse.
- Removed transactions CustomerComplaintNotification and CustomerDisconnectionNotification.

5. Disclaimer

Independent Confirmation - ASWG strongly advises that all information or material contained in this file should be independently verified before use. The user may need to inform themselves of other relevant information or business processes.

No Warranty – Neither ASWG nor any of ASWG's advisers, consultants or other contributors to this file (or their respective associated companies, businesses, partners, directors, officers or employees) make any representation or warranty, express or implied, as to the currency, accuracy, reliability or completeness of the information or material contained in, referred to in or accessed from this file.

No Liability - To the maximum extent permitted by law, neither ASWG nor any of its advisers, consultants or other contributors to this file (or their respective associated companies, businesses, partners, directors, officers or employees) shall have any liability (whether arising from negligence or otherwise) in respect of the use of the file or information contained in, referred to in or accessed from this file (including any reliance on the currency, accuracy, reliability or completeness of the information).