

POWER SYSTEM INCIDENT REPORT TRIP OF MULTIPLE TRANSMISSION LINES IN THE VICINITY OF BRAEMAR 275 KV SUBSTATION 10 JUNE 2010

PREPARED BY: Electricity System Operations Planning and Performance

FINAL

Disclaimer

- (a) *Purpose - This report has been prepared by the Australian Energy Market Operator Limited (AEMO) for the sole purpose of meeting obligations in accordance with clause 4.8.15 (c) of the National Electricity Rules.*
- (b) *No Reliance or warranty – This report contains data provided by third parties and might contain conclusions or forecasts and the like that rely on that data. This data might not be free from errors or omissions. While AEMO has used due care and skill, AEMO does not warrant or represent that the data, conclusions, forecasts or other information in this report are accurate, reliable, complete or current or that they are suitable for particular purposes. You should verify and check the accuracy, completeness, reliability and suitability of this report for any use to which you intend to put it, and seek independent expert advice before using it, or any information contained in it.*
- (c) *Limitation of liability - To the extent permitted by law, AEMO and its advisers, consultants and other contributors to this report (or their respective associated companies, businesses, partners, directors, officers or employees) shall not be liable for any errors, omissions, defects or misrepresentations in the information contained in this report, or for any loss or damage suffered by persons who use or rely on such information (including by reason of negligence, negligent misstatement or otherwise). If any law prohibits the exclusion of such liability, AEMO's liability is limited, at AEMO's option, to the re-supply of the information, provided that this limitation is permitted by law and is fair and reasonable.*

© 2010 - Australian Energy Market Operator Ltd. All rights reserved

1. Introduction

On 10 June 2010 at 12:57 hrs, a high voltage transmission network fault resulted in disconnection of multiple transmission lines in the vicinity of Braemar 275 kV substation and Braemar 2 power station. Approximately 155 MW of generation was disconnected from the transmission network as a consequence.

This report has been prepared under clause 4.8.15 of the National Electricity Rules to assess the adequacy of the provision and response of facilities and services and the appropriateness of actions taken to restore or maintain power system security.

Information for this report has been supplied to AEMO by Powerlink and ERM Power. Data from AEMO's Energy Management and Market Systems has also been used in analysing the event.

All references to time in this report refer to Market time (Australian Eastern Standard Time).

2. Summary of Events

On 10 June 2010 at 12:57 hrs, a high voltage transmission network fault resulted in the disconnection of both Braemar-Tarong 275 kV transmission lines and the two transmission lines connecting Braemar 2 power station to the transmission network. Braemar 2 power station was generating approximately 155 MW before the event with only the No.1 generating unit in service. Powerlink was conducting testing of the auto-reclose functionality of 8814 Braemar-Tarong 275 kV transmission line prior to the event.

Table 1 lists sequence of events that occurred on 10 June 2010 and subsequent restoration of plant during and after 10 June 2010:

Table 1 - Sequence of events including subsequent restoration of plant during and after 10 June 2010

Time	Event/Action	Impact on Transmission Network
10 June 2010 12:57:31 hrs	A single phase trip was initiated to phase A of the transmission line 8814 as part of auto-reclose functionality testing at Tarong 275 kV substation. Phase A of the circuit breaker 88142 tripped and all phases of bus coupler circuit breaker 5042 tripped. At Braemar 275 kV substation, phase A of circuit breaker 88142 tripped and all phases of coupler circuit breaker 5062 tripped (refer to Figures 1 and 2).	Phase A of Braemar-Tarong 275 kV 8814 transmission line disconnected.
10 June 2010 12:57:36.300 hrs	Phase A pole of circuit breaker 88142 at Braemar 275 kV auto-reclosed to re-energise phase A of 8814 transmission line from Braemar 275 kV substation.	Braemar-Tarong 275 kV 8814 transmission line including the line reactor associated with the failed surge arrester open at

	<p>Immediately on closing of phase A pole of circuit breaker 88142 a high voltage phase to earth fault occurred on the power system. The cause of the high voltage fault was the failure of a 275 kV surge arrester associated with 8814 transmission line reactor at Braemar 275 kV substation.</p> <p>The high voltage fault resulted in the operation of 8814 transmission line protection systems at Braemar 275 kV substation. Protection systems tripped circuit breaker 88142 at Braemar (all phases). The coupler circuit breaker 5062 was already open. Protection systems also tripped 8814 transmission line reactor circuit breaker 88142/1 at Braemar 275 kV substation.</p>	<p>Braemar; line still energised via B and C phases at Tarong.</p>
	<p>Coincident with the high voltage transmission network fault the following 275 kV transmission lines also tripped:</p> <ul style="list-style-type: none"> • Transmission line 8815 Tarong – Braemar 275 kV tripped at the Braemar end only via circuit breaker 88152 and bus coupler circuit breaker 5072. The Tarong end of transmission line 8815 remained closed. • Transmission lines 8840 and 8841 connecting Braemar 2 power station to the transmission network also tripped due to operation of Braemar 2 power station protection systems. 	<p>Braemar-Tarong 275 kV 8815 transmission line including the line reactor and surge arrester open at Braemar; 8815 line still energised from Tarong.</p> <p>Braemar-Braemar 2 power station 275 kV 8840 and 8841 transmission lines disconnected.</p>
<p>10 June 2010 12:57:36.500 hrs</p>	<p>By this time 8814 and 8815 Braemar-Tarong 275 kV transmission lines have been disconnected at Braemar substation. Approximately 200 ms after the phase A auto-reclose of circuit breaker 88142 at Braemar, phase A pole of circuit breaker 88142 at Tarong auto-reclosed to successfully re-energise phase A of feeder 8814.</p> <p>Transmission line 8814 reactor circuit breaker 88142/1 at Braemar was open by this time disconnecting the faulty surge arrester from the transmission line 8814 reactor conductors. At this stage all phases of 8814 transmission line were energised from Tarong 275 kV substation and open at Braemar 275 kV substation.</p>	<p>Braemar-Tarong 275 kV 8814 transmission line open at Braemar 275 kV substation; line still energised via all three phases at Tarong.</p>

10 June 2010 13:05 hrs	8814 transmission line manually opened at Tarong end to allow inspection of plant at Braemar end.	Braemar-Tarong 275 kV 8814 transmission line disconnected at Tarong 275 kV substation.
10 June 2010 13:10 hrs	275 kV circuit breaker 88152 at Braemar manually closed.	Braemar-Tarong 275 kV 8815 transmission line restored to service.
10 June 2010 13:11 hrs	Braemar 275 kV circuit breaker 5072 manually closed.	Braemar-Tarong 275 kV 8815 transmission line coupler breaker restored to service.
10 June 2010 14:15 hrs	Braemar 275 kV circuit breakers 88412 and 50512 manually closed.	Braemar - Braemar 2 Power Station 275 kV 8841 transmission line restored to service.
10 June 2010 14:16 hrs	Braemar 275 kV circuit breakers 88402 and 5012 manually closed.	Braemar to Braemar 2 Power Station 275 kV 8840 transmission line restored to service.
10 June 2010 15:52 hrs	Tarong to Braemar 275 kV line 8814 was returned to service after the 8814 reactor and failed surge arrestor at Braemar were isolated from the feeder (by opening of reactor isolator).	Braemar-Tarong 275 kV 8814 transmission line restored to service.
10 June 2010 16:08 hrs	Transmission line 8814 taken out of service after smoke was identified coming from the base box of Capacitor Voltage Transformer (CVT) at Tarong 275 kV substation.	Braemar-Tarong 275 kV 8814 transmission line out of service.
11 June 2010 14:48 hrs	Restored transmission line 8814 after the phase A line CVT at Tarong was replaced.	Braemar-Tarong 275 kV 8814 transmission line restored to service.
23 June 2010 13:28 hrs	Restored 8814 transmission line reactor at Braemar after replacement of the surge arrestor.	Braemar-Tarong 275 kV 8814 transmission line reactor and surge arrestor restored to service.

Transmission network arrangements and circuit breaker status at Braemar 275 kV substation and Tarong 275 kV substation before and after the high voltage transmission network fault are shown in Figures 1 and 2.

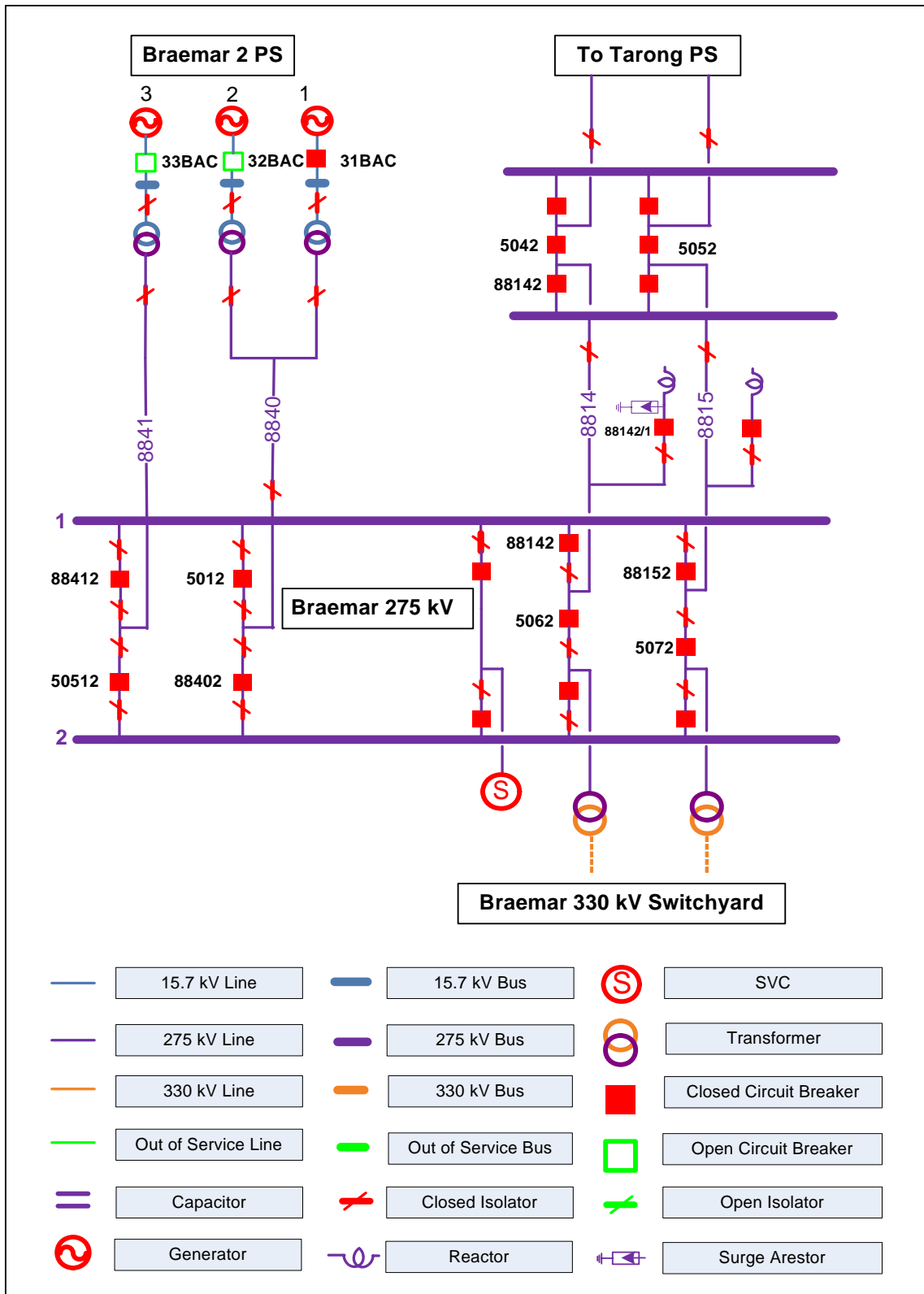

Figure 1: Single line diagram showing status of the relevant transmission plant at Braemar and Tarong 275 kV substation before the high voltage transmission network fault

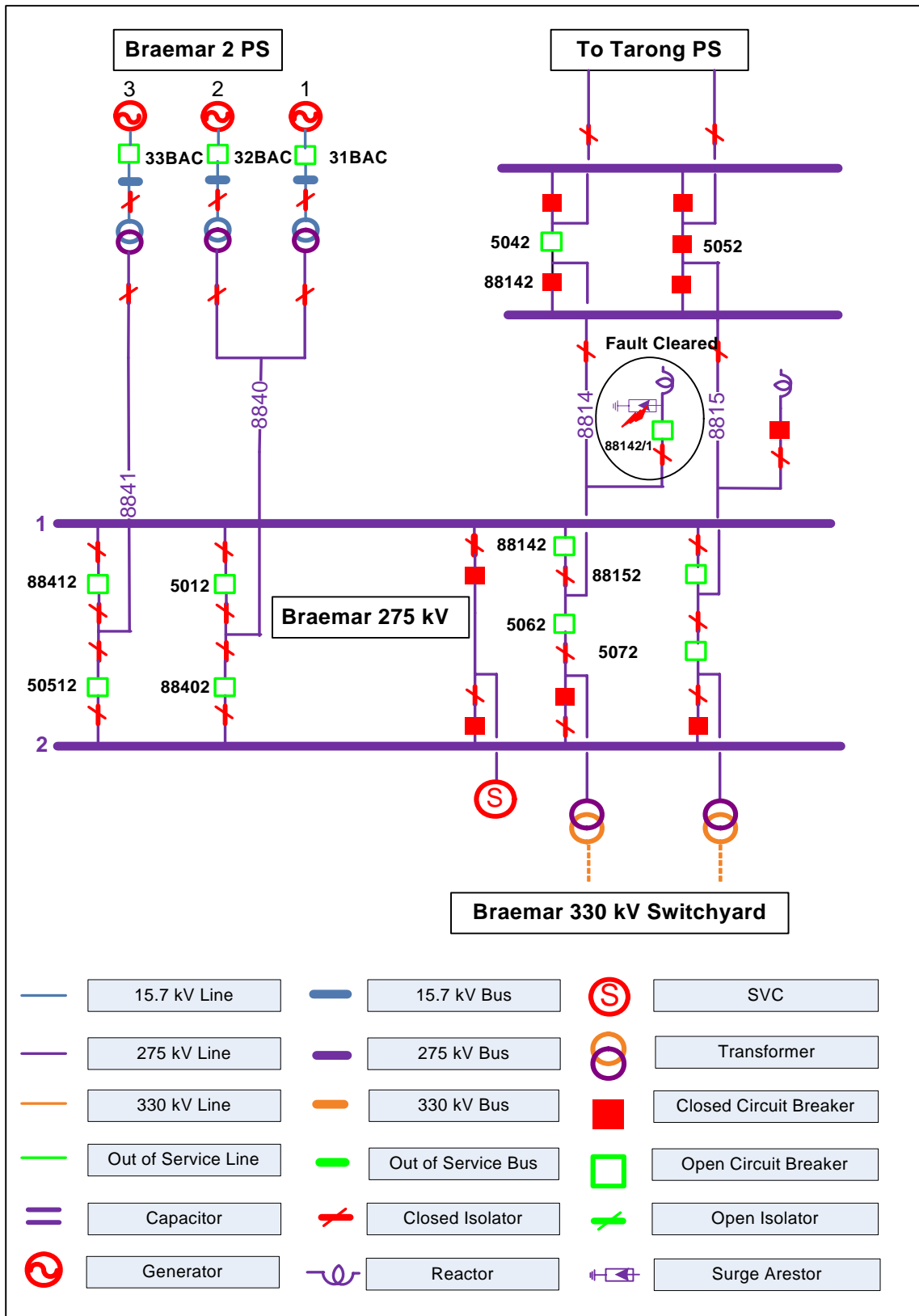

Figure 2: Single line diagram showing status of relevant transmission plant at Braemar and Tarong 275 kV substation after the high voltage transmission fault

3. Management of Power System Security

The high voltage transmission network fault associated with Braemar-Tarong 275 kV 8814 transmission line resulted in disconnection of multiple transmission lines from the transmission network. The only in service No.1 generating unit at Braemar 2 Power Station at the time also tripped from approximately 155 MW.

The power system frequency remained within the normal operating frequency band due to the delivery of contingency FCAS services.

AEMO's real time contingency analysis (RTCA) tool showed violations for the loss of either of the Braemar to Bulli Creek 330 kV lines 9901 or 9902 and the loss of either of the Braemar 330/275 kV transformers. AEMO had produced an automated constraint equation to manage these violations but it did not need to be invoked due to the prompt return to service of Tarong to Braemar 275 kV line 8815.

A constraint set was not invoked for the outage of 8814 line, from 12:57 hrs to 15:52 hrs, as no library constraint set was available. Automated constraint equation(s) were not able to be created because the constraint automation modelling did not include the required line flows. AEMO's RTCA was used to monitor system security during this outage and no violations were reported. There was no interruption to supply.

AEMO's constraint builders subsequently constructed constraint equations for the outage of 8814 or 8815 transmission line. These were invoked at 1620 hrs as Powerlink had informed AEMO that 8814 needed to be taken out of service after smoke was identified coming from the base box of Capacitor Voltage Transformer (CVT) at Tarong 275 kV substation.

The high voltage transmission network fault was cleared by the protection systems at Braemar and Tarong 275 kV substation within the requirements specified in the National Electricity Rules (NER) and there were no power system security violations during the event.

The high voltage transmission network fault existed on conductors associated with Braemar-Tarong 275 kV 8814 transmission line resulting in disconnection of transmission lines 8815, 8840 and 8841.

Based on the information available immediately following the non-credible event on 10 June 2010, AEMO did not reclassify the loss of Braemar 2 power station as a credible contingency. This is because the initiating event that caused the non-credible contingency to occur was external to Braemar 2 power station and the tripping of the lines to Braemar power station appeared to be due to Powerlink equipment.

However, following the subsequent investigation of this event, and a similar event that occurred on 13 November 2009^[1], it was concluded that Braemar 2 power station was prone to tripping for close proximity transmission network faults and that the loss of Braemar power station should be declared credible. This did not occur because the problem that was causing the tripping of multiple Braemar generators was resolved on 18 June 2010; prior to the completion of the investigation. Analysis confirmed that sufficient FCAS services were enabled to cover the largest risk on the power system and by default covered the loss of Braemar 2 power station during the period from 13 November 2009 to 18 June 2010.

The following section describes reasons for disconnection of multiple transmission lines, investigation and remedial actions undertaken by Powerlink and ERM Power.

4. Follow up actions

4.1 Braemar 275 kV Switchyard Events

Investigation undertaken by Powerlink after the event uncovered that the failure of the surge arrester and the CVT associated with Braemar-Tarong 275 kV 8814 transmission line was due to an overvoltage condition. The investigation identified that when a single phase of the 8814 transmission line is open while the other two phases are in service, an overvoltage condition could result on the open phase due to resonance between the 8814 transmission line reactor at Braemar 275 kV substation and the open phase of the transmission line.

This condition occurs as a result of the 8814 transmission line reactor earthing configuration at Braemar 275 kV substation. To eliminate the risk of the occurrence of over-voltage, the single pole auto-reclose on both Braemar-Tarong 275 kV transmission lines (8814 and 8815) has been turned off. Three pole auto-reclose on these lines remains in service.

Investigation found that the feeder 8815 transmission line Y protection relay at Braemar 275 kV substation had a setting issue causing it to operate for the high voltage fault on feeder 8814. Powerlink resolved this issue by modifying the relay setting on 10 June 2010.

4.2 Events at Braemar 2 Power Station

Coincident with the high voltage transmission network fault on the Braemar-Tarong 275 kV 8814 transmission line, Braemar 2 power station sent an inter-trip signal to trip transmission lines 8840 and 8841 connecting Braemar 2 Power Station to the transmission network. At the time of this event, ERM Power was investigating a similar event that occurred in November 2009^[1].

^[1] The power system incident report titled “Trip of multiple transmission lines in the vicinity of Braemar 275 kV substation – 13 November 2009” is available at:

<http://www.aemo.com.au/reports/nemreports.html#ops>

The investigation included revision of the design, commissioning and partial re-testing of the protection systems at Braemar 2 power station. During the course of the investigation, several shortcomings in the implementation of the protection system were identified. However, identification of the exact cause of the tripping of the power station was very difficult.

While the investigation was continuing, the 10 June 2010 close proximity network fault occurred. With the experience of the first event, the operations team was able to gather useful information from this second power station tripping. Using this new information, the likely cause of the power station tripping was identified as non-selection of zero-sequence filtering feature in its overall differential protection and a test to verify this explanation was devised. Site testing confirmed the correctness of the explanation. On the basis of site testing, adjustments were made to the protection system and retested/commissioned on 18 June 2010.

5. Conclusions

During the testing of auto-reclose functionality of Braemar-Tarong 275 kV 8814 transmission line a high voltage transmission network fault was experienced. The fault on the transmission network was caused by high voltages experienced when a single phase of transmission line 8814 was energised from the Tarong end only. The fault resulted in disconnection of other near-by transmission lines as well as the Braemar 2 power station.

Powerlink disabled the single phase auto-reclose functionality on transmission lines 8814 and 8815 as a temporary measure to avoid similar incidents occurring in future. Powerlink is investigating a suitable long term strategy to eliminate the possibility of similar high voltage conditions occurring following single phase auto-reclose on the 8814 or 8815 lines.

Investigations conducted by ERM Power concluded that the Braemar 2 power station overall differential protection system was too sensitive to transmission network faults, resulting in the power station being disconnected from the power system on two occasions. ERM has modified the overall differential protection system so that it can withstand close proximity transmission network faults. The revised protection system has been tested and implemented.

6. Recommendations

Powerlink will advise AEMO of the outcomes of its investigation on suitable measures to avoid high voltage conditions on the Braemar-Tarong 275 kV 8814 or 8815 transmission lines during single pole auto-reclose, by December 2010.

AEMO will modify its Power System Security Guidelines to ensure that following a non-credible contingency event information is sourced from contributing and affected parties as soon as practically possible to determine if the condition that caused the non-credible contingency event has been identified and addressed. If AEMO is unable to obtain the appropriate level of information to determine this, then AEMO will reclassify the event as a credible contingency event. This task will be completed by the end of October 2010.