

# Power System Operating Incident Report – Opening of Dapto – Marulan No.8 330 kV Transmission Line at the Dapto End Only on 28 October 2013

PREPARED BY: AEMO Systems Capability

DATE: 24 December 2013

FINAL

## Contents

1.	Introduction .....	4
2.	The Incident .....	4
3.	TNSP Investigation - TransGrid.....	4
4.	Pre-Incident State .....	4
5.	Incident Event Log.....	4
6.	Post Incident State .....	6
7.	Immediate Actions .....	6
8.	Follow-Up Actions .....	7
9.	Power System Security.....	7
10.	Conclusions .....	7
11.	Recommendations .....	7

## Disclaimer

### Purpose

This report has been prepared by the Australian Energy Market Operator Limited (AEMO) for the sole purpose of meeting obligations in accordance with clause 4.8.15 (c) of the National Electricity Rules (NER).

### No reliance or warranty

This report contains data provided by third parties and might contain conclusions or forecasts and the like that rely on that data. This data might not be free from errors or omissions. While AEMO has used due care and skill, AEMO does not warrant or represent that the data, conclusions, forecasts or other information in this report are accurate, reliable, complete or current or that they are suitable for particular purposes. You should verify and check the accuracy, completeness, reliability and suitability of this report for any use to which you intend to put it, and seek independent expert advice before using it, or any information contained in it.

### Limitation of liability

To the extent permitted by law, AEMO and its advisers, consultants and other contributors to this report (or their respective associated companies, businesses, partners, directors, officers or employees) shall not be liable for any errors, omissions, defects or misrepresentations in the information contained in this report, or for any loss or damage suffered by persons who use or rely on such information (including by reason of negligence, negligent misstatement or otherwise). If any law prohibits the exclusion of such liability, AEMO's liability is limited, at AEMO's option, to the re-supply of the information, provided that this limitation is permitted by law and is fair and reasonable.

© 2013 Australian Energy Market Operator Ltd. All rights reserved

## Version Release History

VERSION	DATE	BY	CHANGES	CHECKED BY	AUTHORISED BY
1	17 Dec 2013	R Wettimuny	FINAL	S Darnell	P Biddle

## Incident Classifications

Time and date and of incident	0724 hrs 28 October 2013
Region of incident	NSW
Affected regions	NSW
Event type	OTH - Other
Primary cause	UNK - Unknown
Impact	Nil
Associated reports	Nil

## Abbreviations

Abbreviation	Term
AEMO	Australian Energy Market Operator
CB	Circuit Breaker
EMMS	Electricity Market Management System
EMS	Energy Management System
kV	Kilovolt
NER	National Electricity Rules

## 1. Introduction

This report reviews a power system operating incident that occurred on 28 October 2013 in the New South Wales region at TransGrid's Dapto sub-station. AEMO is required to review this incident as it is classified as a non-credible contingency that satisfies the requirements of a reviewable operating incident under the National Electricity Rules<sup>1</sup> (NER).

The purpose of this incident review is to assess power system security over the course of the incident. The NER requires AEMO to assess the adequacy of the provision and response of facilities and services and the appropriateness of actions taken to restore or maintain power system security<sup>2</sup>.

This report is largely based upon information provided by TransGrid. Data from AEMO's Energy Management System (EMS) and Electricity Market Management System (EMMS) has also been used in analysing the incident.

All references to time in this report are to National Electricity Market time (Australian Eastern Standard Time).

## 2. The Incident

On Monday 28 October 2013 at 0724 hrs the Dapto – Marulan No.8 330 kV transmission line opened at the Dapto end only. This was an unexpected event. At 0732 hrs, the transmission line was successfully returned to service.

The primary purpose of this reviewing this incident is to investigate the opening of a transmission line at one end only. Generally, protection and control schemes for transmission lines are configured to open transmission lines at both ends under fault conditions.

## 3. TNSP Investigation - TransGrid

TransGrid found that the incident was caused by a firmware problem with a protection relay. Subsequently, in November, TransGrid upgraded the firmware on the protection relay to resolve the problem. TransGrid is also upgrading the firmware across a fleet of similar relays.

## 4. Pre-Incident State

The status of the power system prior to the incident is shown in Figure 1. For clarity only equipment relevant to this incident has been included in the diagram. The diagram shows the Dapto – Marulan No.8 330 kV transmission line in service.

## 5. Incident Event Log

The sequence of events comprising the incident is itemised in Table 1. The incident spanned approximately 8 minutes from No. 82 CB at Dapto opening to the power system being returned to the pre-incident state.

---

<sup>1</sup> NER v59 Clause 4.8.15(a)(1)(i) and AEMC Reliability Panel Guidelines for Identifying Reviewable Operating Incidents.

<sup>2</sup> NER v59 Clause 4.8.15 (b)

**Figure 1 - Status of the power system prior to the incident**

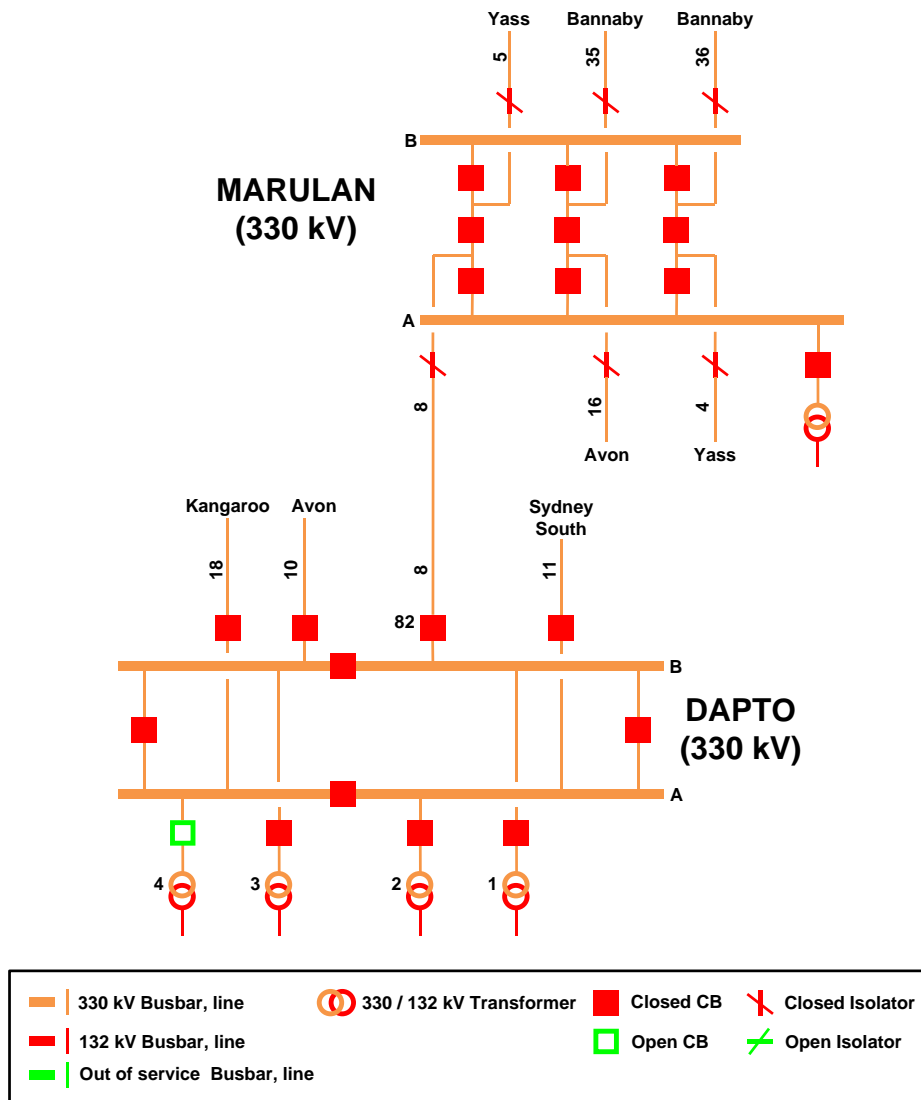

**Table 1 – Event Log**

Time	Event
28 Oct 2013 0724 hrs	Dapto – Marulan No.8 330 kV line CB No. 82 at Dapto opened automatically
28 Oct 2013 0732 hrs	Dapto – Marulan No.8 330 kV line CB No. 82 at Dapto closed manually
28 Oct 2013 1100 hrs	Market Notice 43743 issued to notify the market of the non-credible contingency event
28 Oct 2013 1109 hrs	Market Notice 43744 issued to notify the market that the event has been classified as a non-credible contingency
2 Dec 2013 1409 hrs	Market Notice 44072 issued to notify the market to cancel the reclassification

## 6. Post Incident State

The status of the power system immediately after the incident is shown in Figure 2. The diagram shows the Dapto – Marulan (8) 330 kV transmission line open at the Dapto end.

**Figure 2 - Status of the power system immediately after the incident**

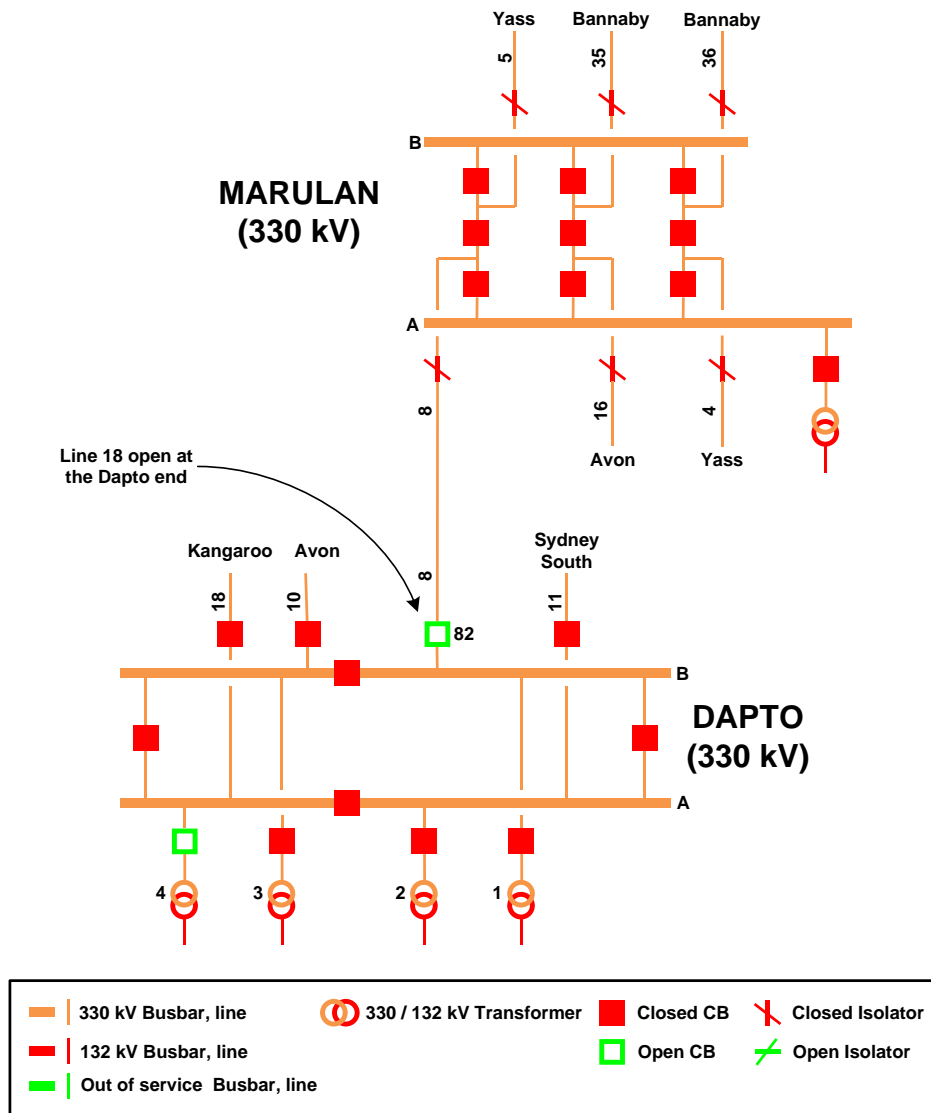

## 7. Immediate Actions

At 0732 hrs, TransGrid reclosed 330 kV CB No. 82 at Dapto substation. This returned to service the Dapto – Marulan No.8 330 kV transmission line.

AEMO did not invoke any constraint sets to manage power system security since the Dapto – Marulan (8) 330 kV transmission line was returned to service within 8 minutes.

AEMO issued Market Notice 43743 to notify the market of the non-credible contingency event. This notice was issued 3 hours and 36 minutes after the initial event which is outside the two hour period that AEMO is required to notify the market of a non-credible contingency event<sup>3</sup>.

<sup>3</sup> AEMO, Power System Security Guidelines, v59 Section 10.3

## 8. Follow-Up Actions

For a non credible contingency AEMO is required to assess whether or not to reclassify the event as a credible contingency<sup>4</sup> and to report how re-classification criteria were applied<sup>5</sup>. AEMO has to determine if the condition that caused the non-credible contingency event has been resolved.

For this event AEMO reclassified as a credible contingency the opening of Dapto – Marulan No.8 330 kV transmission line at one end. AEMO considered that there was insufficient information to determine that the cause of the event had been resolved and was unlikely to re-occur. AEMO issued Market Notice 43744 at 1109 hrs to notify the market that AEMO had reclassified this event.

On 2 December 2013 TransGrid advised AEMO that the firmware for the protection relay at Dapto had been upgraded and problem was unlikely to re-occur. AEMO cancelled the reclassification at 1409 hrs on 2 December 2013 and issued Market Notice 44072 to notify the market of the cancellation.

## 9. Power System Security

AEMO is responsible for power system security in the NEM and is required to operate the power system in a secure operating state<sup>6</sup>. AEMO must thereby ensure that the power system is maintained in, or returned to, a secure operating state within 30 minutes following a contingency event

For the trip of Dapto – Marulan No.8 330 kV transmission line, AEMO would normally invoke constraint sets to ensure the power system was maintained in, or returned to, a secure operating state. In this case constraint sets were not required because TransGrid restored the line back to service within 8 minutes. This prompt action by TransGrid returned the power system to a secure operating state as soon as practicable.

Over the course of the incident the provision and response of facilities and services were adequate to maintain/restore the power system security. AEMO and TransGrid took appropriate actions to maintain power system security.

## 10. Conclusions

1. The opening of the Dapto – Marulan No.8 330 kV transmission line at the Dapto end on 28 October 2013 was caused by a problem with a protection relay firmware. The problem was later resolved.
2. AEMO failed to issue Market notice 43743 within the required times frame.

## 11. Recommendations

There are no recommendations arising from this investigation.

---

<sup>4</sup> NER v59 Clause 4.2.3A (c)

<sup>5</sup> NER v59 Clause 4.8.15 (Ca)

<sup>6</sup> NER v59 Clause 4.2.4 (a)