

GUIDELINES FOR SHARED TRANSMISSION CONNECTIONS IN VICTORIA

PREPARED BY: Transmission Services

VERSION: 2.0

RELEASE DATE: 14 December 2011

FINAL

Version Release History

Version	Date	Approved
1.0	3 Jun 11	Transmission Services
2.0	14 Dec 11	Transmission Services

This document is made available to you on the following basis:

- (a) Purpose – These Guidelines for Shared Transmission Connections in Victoria (Guidelines) have been produced by the Australian Energy Market Operator Limited (AEMO) to provide information about shared network connections in Victoria as at the date of publication.*
- (b) No substitute – These Guidelines are not a substitute for, and should not be read in lieu of, the National Electricity Law (NEL), the National Electricity Rules (NER) or any other relevant laws, codes, rules, procedures or policies. Further, the contents of these Guidelines do not constitute legal or business advice and should not be relied on as a substitute for obtaining detailed advice about the NEL, the NER, or any other relevant laws, codes, rules, procedures or policies, or any aspect of the national electricity market or the electricity industry.*
- (c) No Warranty – While AEMO has used due care and skill in the production of these Guidelines, neither AEMO, nor any of its employees, agents and consultants make any representation or warranty as to the accuracy, reliability, completeness or suitability for particular purposes of the information in these Guidelines.*
- (d) Limitation of liability - To the extent permitted by law, AEMO and its advisers, consultants and other contributors to these Guidelines (or their respective associated companies, businesses, partners, directors, officers or employees) shall not be liable for any errors, omissions, defects or misrepresentations in the information contained in these Guidelines, or for any loss or damage suffered by persons who use or rely on such information (including by reason of negligence, negligent misstatement or otherwise). If any law prohibits the exclusion of such liability, AEMO's liability is limited, at AEMO's option, to the re-supply of the information, provided that this limitation is permitted by law and is fair and reasonable.*

© 2011 - All rights reserved

Contents

1	Purpose.....	5
2	Application.....	5
3	Legal and Regulatory Framework	5
4	Related Policies and Procedures	5
5	Standard Transmission Connection	5
5.1	Determining the Connection Arrangement.....	10
6	Rationale for Acceptability Criteria	11
6.1	Maintainability and Safety.....	11
6.2	Site Expandability.....	12
6.2.1	Negotiated Single Connections.....	12
6.2.2	Sites Developed for Multiple Connections	12
6.2.3	Physical Connection.....	13
6.3	Protection.....	13
6.4	Regulatory and Other Issues.....	14
6.5	Reliability of Shared Transmission Network.....	14
7	Acceptability Criteria	14
7.1	Complexity, Maintainability and Safety	14
7.2	Site Expandability.....	15
7.3	Physical Connection.....	15
7.4	Reliability of Shared Transmission Network.....	15
7.5	Protection.....	15
7.6	Technical Analysis under Schedules 5.2 and 5.3 of the Rules.....	15
7.7	Potential Loss of Generation for a Credible Contingency	15
	Appendix A: Assessment of Alternative Connection Arrangements.....	16

1 Purpose

AEMO has prepared these Guidelines to provide information to assist connection applicants seeking to connect to the Victorian Declared Shared Network (DSN). In Victoria, SP AusNet is the principal (although not the only) transmission asset owner and declared transmission system operator (DTSO). AEMO exercises statutory functions in respect of the DSN, including the provision of shared transmission services by means of the DSN.

These Guidelines have been developed to promote the optimal development of new connections to the DSN. They are consistent with AEMO's current long-term network development plans, the National Electricity Rules (Rules), and present transmission and generating plant and operational practice.

2 Application

These Guidelines apply to new connections to the DSN at the voltage levels of 500 kV, 330 kV, 275 kV and 220 kV.

3 Legal and Regulatory Framework

The Rules set out the processes and procedures that DTSOs and connection applicants must follow to add a new connection to the DSN. Depending on the size, scope, timing and location of new connections, augmentation to the DSN may be required to facilitate a connection.

While a range of technical requirements for the establishment of a connection are detailed in the Rules, certain technical matters regarding acceptable connection point arrangements are not. Section 50C of the National Electricity Law (NEL) outlines AEMO's 'declared network functions' in Victoria, which include an obligation to plan, authorise, contract for, and direct any augmentations to the DSN. AEMO interprets this as acting to ensure that terminal stations are designed and built so that they do not inhibit any future development in line with AEMO's planned augmentations, including planning for ultimate station configurations. In accordance with Clause 6A.9.1(2) of the Rules, AEMO will not require connecting parties to pay more than their stand-alone connection costs for an acceptable connection. Works necessary for anticipated future connections are to be funded as prescribed services. Further information on this can be found in AEMO's Guidelines for Establishing Terminal Stations in Victoria.

4 Related Policies and Procedures

These Guidelines are related to other policies, procedures and guidelines produced by AEMO and should be read in conjunction with the following documents.

- Guidelines for Establishing Terminal Stations in Victoria.
- Cost Allocation Policy in Victoria.
- Connecting Victoria: Transmission Project Development Protocol.

5 Standard Transmission Connection

AEMO understands that, historically, many approaches have been taken in making connections to the DSN; however, AEMO does not believe these set a precedent for any method of connection for the future. The direct connection of new loads or generation to existing transmission lines in Victoria will require the establishment of entirely new connection points. These Guidelines identify acceptably secure connection arrangements for those connections.

While several differing switching arrangements are used across Victoria, in choosing a standard connection arrangement AEMO notes that the majority of new connections cut into a single pre-

existing transmission line. The most appropriate switching arrangement for this type of connection in Victoria is a breaker-and-a-half configuration, which uses a minimum of three circuit breakers to cut into an existing circuit.

While a breaker-and-a-half arrangement requires more circuit breakers when compared to a tee connection it should result in lower equipment costs¹ than a double-busbar arrangement with a similar level of functionality. The reliability and availability of the existing circuit is maintained to a significant extent and, additionally, this arrangement lends itself to augmentation, extension and rearrangement at a later date with minimal disruption to the connecting circuits or existing connection(s).

Within the breaker-and-a-half arrangement, transmission line entry and exits may be made within common or alternate bays. The preferred arrangement will vary according to the location, size and type of connection (i.e. generation or load). Consistent with AEMO’s obligations to all connected parties under Clause 5.2.3 of the Rules, AEMO will select the arrangement that provides an optimal combination of:

- security and continuity of the connecting transmission line(s), which relates to maintaining the connection between the remote terminal stations (Terminal Stations A and B in Figure 5–1); and
- service to the newly connecting generation or load, which relates to maintaining a connection between the newly connecting generation or load and either of the remote terminal stations (Terminal Stations A or B in Figure 5–1).

The practice of connecting transmission line entries and exits in a common bay provides a shorter current path via a centre circuit breaker, which is independent of other plant within the terminal station (including busbars). It allows each circuit to be switched between busbars without outages, maintaining connection for a single-busbar outage and maintains continuity of the line for a double-busbar outage. This arrangement is shown in Figure 5–1.

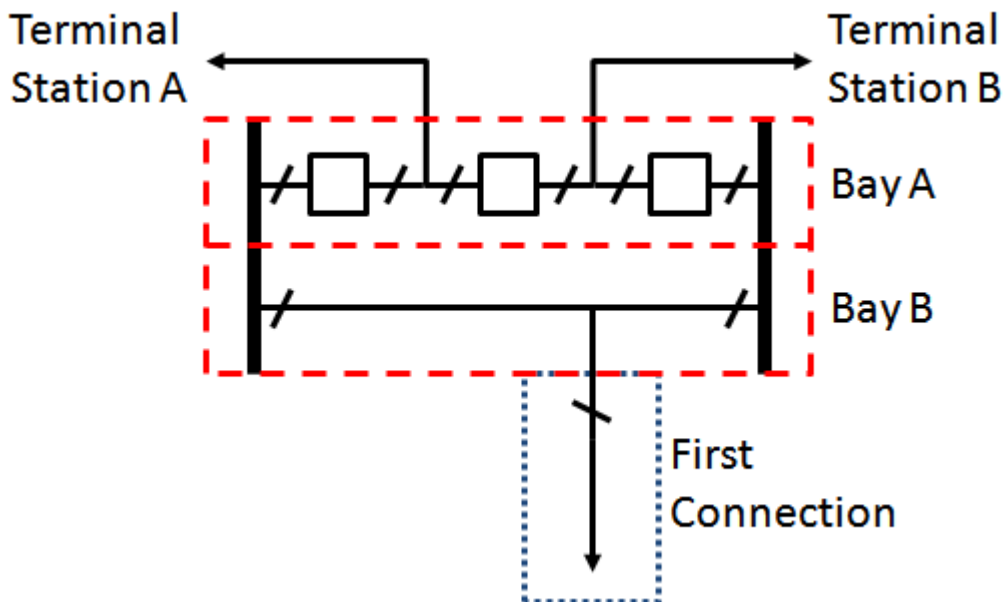

Figure 5-1: Initial establishment of a connection – transmission line connections in a common bay

¹ A breaker-and-a-half arrangement requires three circuit breakers and four busbar sections to cut into a line (only two further busbar sections are required if cutting a station into a second line), while a double-busbar arrangement requires four circuit breakers and four busbar sections to achieve the same.

The arrangement in Figure 5-1 is particularly suited to either of the following circumstances:

- The capacity and loading of the connecting transmission line is large in relation to the proposed generation or load connection.
- A secure generation or load connection cannot usually be maintained without connection to both remote Terminal Stations A and B.

A connection arrangement may be modified from that shown in Figure 5-1 to provide improved levels of flexibility and security if required by the connection applicant. Such an arrangement, which provides improved security and operational flexibility over the minimum three circuit breaker arrangement shown in Figure 5-1, is shown in Figure 5–2.

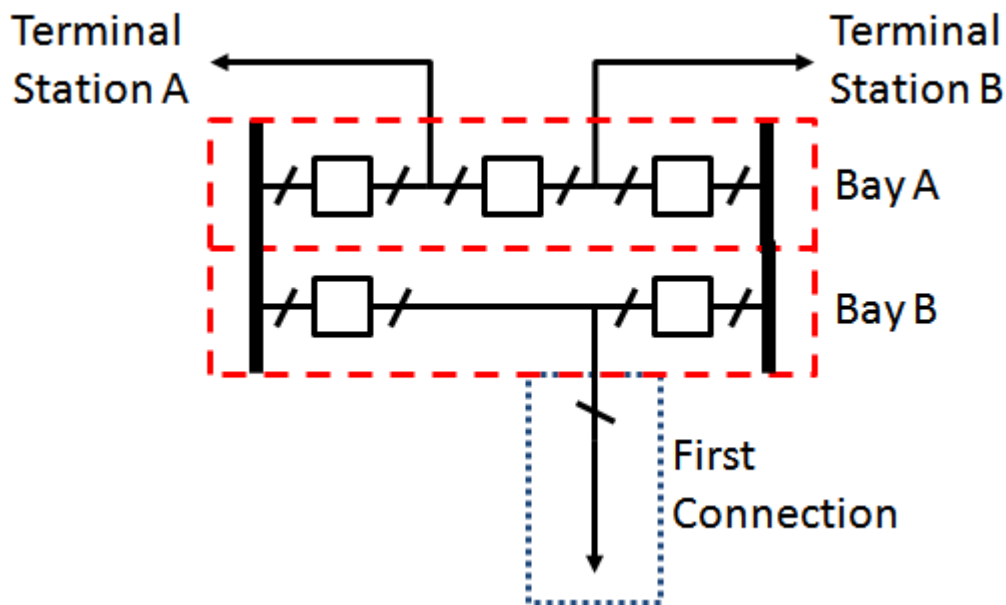

Figure 5–2: Initial establishment of a connection – an alternative five circuit breaker arrangement

The connection can then be further augmented as future connections are made by other parties, as long as nothing is done to impede potential development to the ultimate station configuration. For example, the arrangements shown in Figure 5-1 or Figure 5–2 may be expanded to accommodate a second connection as shown in Figure 5–3. This could be achieved without disrupting the continuity of the connecting line through the station.

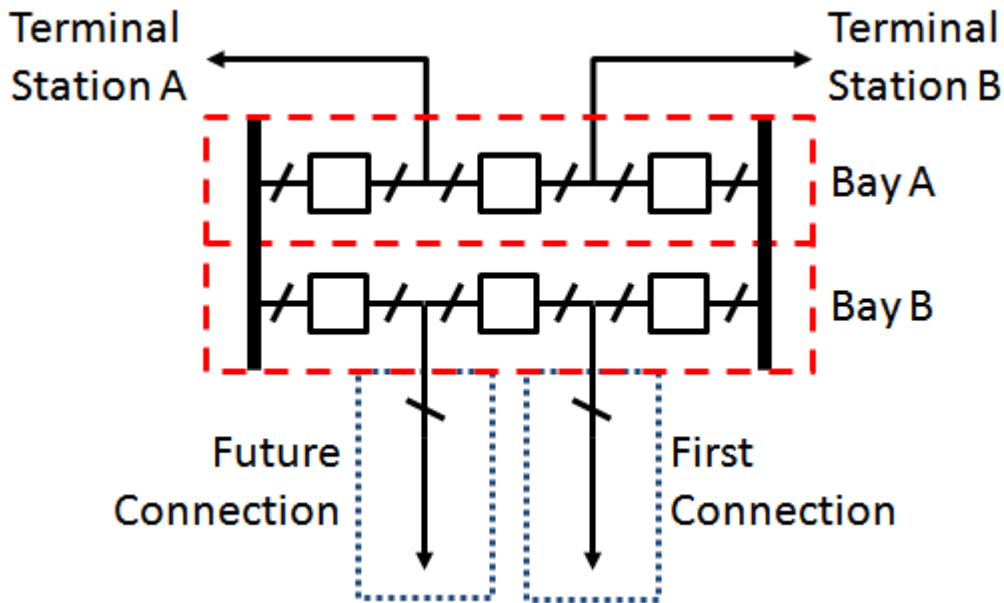

Figure 5-3: Establishing a second connection – transmission line connections in a common bay

Connection of transmission line entry or exits in alternate bays provides a shorter current path between line and generation, or line and load, via a centre circuit breaker that is independent of other plant within the terminal station (including busbars). It maintains connection for a single-busbar outage and can maintain reduced service to a generation or load connection point via a single line for a double-busbar outage. An example of alternating entries and exits in adjacent bays is shown in Figure 5-4.

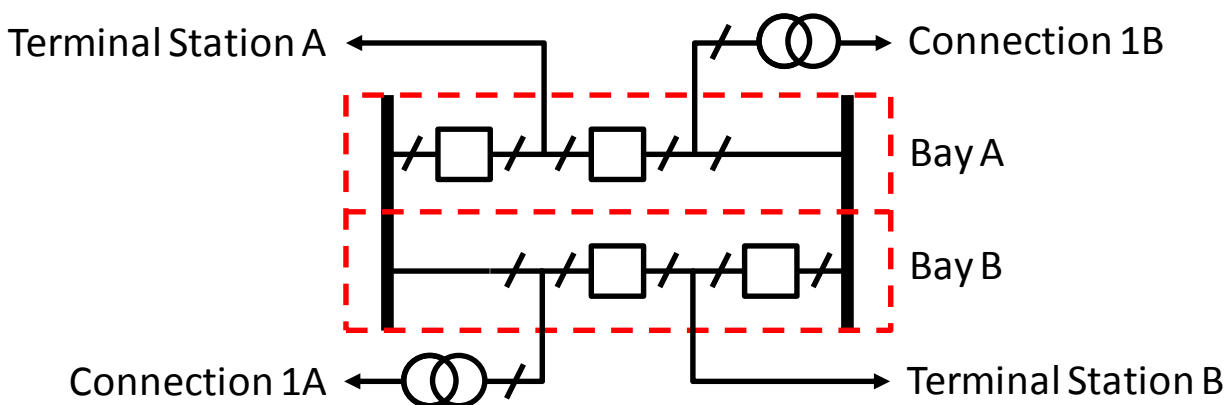

Figure 5-4: Initial establishment of a connection – transmission line connections in alternate bays

The arrangement in Figure 5-4 is particularly suited to the following situations:

- Multiple transmission paths exist between remote Terminal Stations A and B.
- A more secure connection is required from either remote Terminal Station A or B.
- The connecting party is supplied via two or more connection points within the new terminal station (Connections 1A and 1B) and the likelihood of a single outage affecting both connections is to be reduced.

A connection arrangement may be modified from that shown in Figure 5-4 to provide improved levels of flexibility and security if required by the connection applicant. Such an arrangement is shown in Figure 5-5.

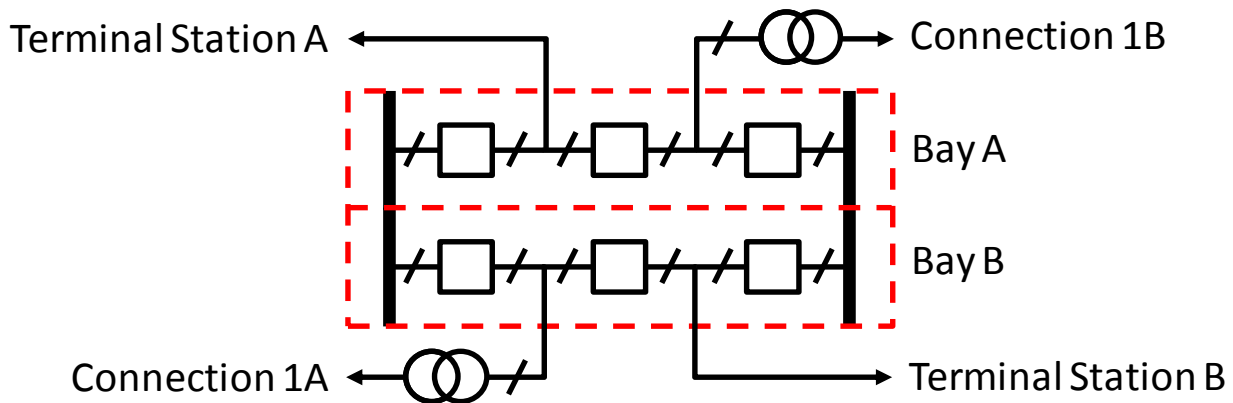

Figure 5–5: Initial establishment of a connection – alternative six circuit breaker arrangement

The arrangement in Figure 5–5 may be expanded to accommodate further connections by the construction of new bays.

It should be noted that the arrangements illustrated by the figures in this section of the Guidelines are indicative schematic representations of possible connection arrangements in Victoria only. The physical layout of equipment will be determined on a site-by-site basis so as not to impede development to the future ultimate station configuration.

AEMO's preference is that all new connection applications be made specifying the breaker-and-a-half configuration. A connection applicant may request a departure from the breaker-and-a-half configuration, particularly if it wants to establish a more secure connection arrangement. Any request for a less secure connection will be assessed against acceptability criteria, set out in Section 7 of these Guidelines.

AEMO currently engages in joint planning with Distribution Network Service Providers (DNSPs) in Victoria, so that AEMO is aware of potential future connections well in advance of any works commencing. The connection arrangement for a new or augmented distribution terminal station would therefore be defined to the acceptability of AEMO and the DNSP before the receipt of a connection application. For more information on the joint planning process please refer to AEMO's Guidelines for Ultimate Station Configurations in Victoria.

5.1 Determining the Connection Arrangement

Figure 5-6 outlines the process to determine the method of connection to the DSN. It is written from the point of view of AEMO’s interaction with the connection applicant and is integrated with current practices, such as joint planning processes with DNSP’s.

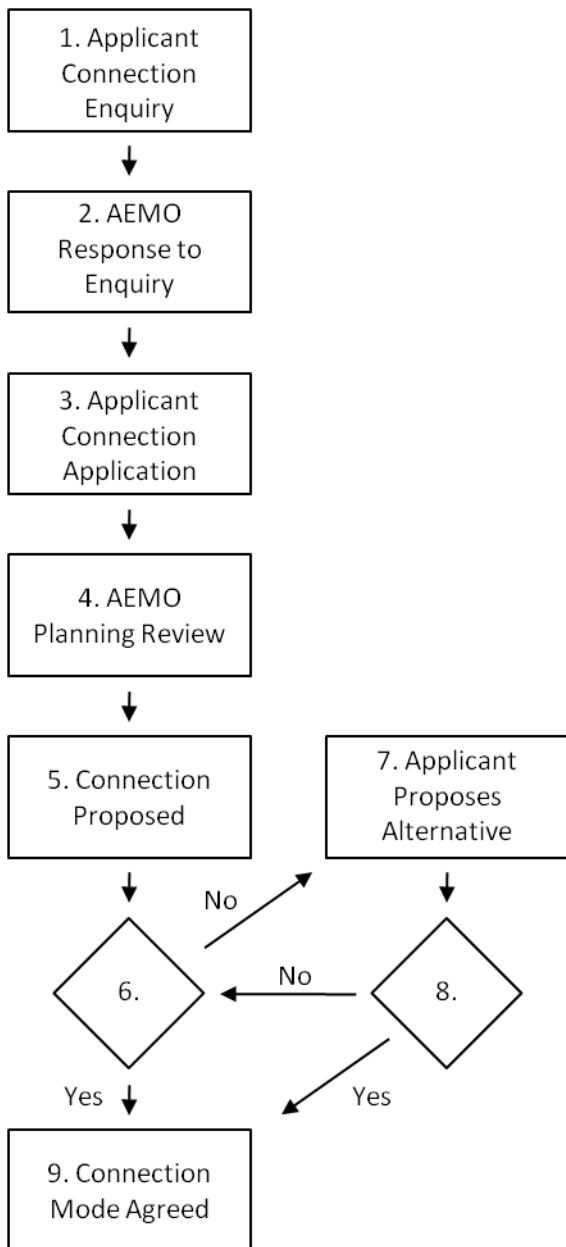

- 1. Applicant Connection Enquiry**
Applicant identifies size, location and preferred voltage for connection.
- 2. AEMO Response to Enquiry**
AEMO identifies known potential issues with the proposed connection and location.
- 3. Connection Application**
Connection applicant provides further technical detail, including the generating system model, proposed connection arrangement and location to cover initial work required by AEMO.
- 4. AEMO Planning Review**
AEMO reviews the proposed connection arrangement and location in consultation with any other affected network service providers. AEMO will accept where it meets, or, with minor alterations, can meet, acceptability criteria. If this proposal is unsuitable or suboptimal, AEMO will propose a suitable alternative arrangement, location, or both.
- 5. Connection Proposed**
AEMO advises connection applicant of method that meets acceptability criteria.
- 6. Connection Applicant Accept/Reject**
Connection applicant accepts or rejects AEMO’s proposal. If the connection applicant accepts the proposal, move to (9). If the applicant rejects the proposal, move to (7).
- 7. Connection Applicant Alternative**
If the connection applicant rejects AEMO’s proposal, the connection applicant proposes a more suitable alternative to meet its needs while still meeting acceptability criteria. This must be submitted with a detailed justification of why it meets acceptability criteria for the nominated alternative arrangement, and alternative location, if proposed.
- 8. AEMO Accept/Reject**
AEMO accepts or rejects the connection applicant’s alternative proposal. If AEMO rejects the proposal, AEMO proposes modifications that meet acceptability criteria; move to (6). If AEMO accepts the connection applicant’s alternative proposal, move to (9).
- 9. Connection Mode Agreed**
Connection mode is accepted by both AEMO and the applicant. If a mutually acceptable connection that complies with the Rules cannot be agreed, then a transmission services access dispute process would be initiated.

Figure 5-6: Process flow chart

6 Rationale for Acceptability Criteria

6.1 Maintainability and Safety

AEMO must ensure that the time required to effect isolation and earthing in preparation for planned or unplanned maintenance work is kept to a minimum. It is important to ensure that the time taken to perform this operation is not disproportionate to the time required to carry out the maintenance. This would lead to inefficiencies in maintenance and repair times and AEMO would not be able to meet the requirements of Clause S5.1.2.1(d) of the Rules or, by remaining within the time required by this clause, require multiple outages over a prolonged period.

The increased complexity in isolation of a line with multiple tee connections increases the risk of human error and the possibility accidents. More tee connections require either more work crews or more movements by each work crew to effect safe isolation. This issue is exacerbated with increasing line length and distance between connections on the line.

Any new terminal station should be considered in the light of the number of existing terminations on the circuit(s) to which the new station is to be connected and also any adjacent circuits. Consideration must be given to the ease with which the connecting circuit(s) can be safely isolated once the connection is made. To this end, AEMO proposes:

- to limit the facilities by which any DSN circuit may be isolated and earthed to three individual sites²; and
- the normal operational procedure for the isolation and earthing of DSN circuits shall not require the operation of more than five circuit breakers³ in total.

AEMO developed this approach from its review of current international practice and it is consistent with that adopted in the United Kingdom by National Grid in its National Electricity Transmission System Security and Quality of Supply Standard⁴, which forms part of the Grid Code. The approach is also consistent with the experience of other Australian TNSPs (transmission network service providers) and transmission asset owners. The intent of these requirements is to limit the potential for human error resulting from complex circuit arrangements and even tighter timeframes within which work must occur.

The existence of multiple tees on non-radial lines leads to unnecessary interruptions to other users when one user requires work on its branch. Further, the involvement of multiple parties in determining timings for outages can become unworkable as the number of parties and the diversity of interests increase. Similarly, if unplanned outages occur, the diversity of stakeholders and the potentially large geographical region that must be covered to ensure safe re-establishment of supply can be problematic.

Once an outage is arranged, isolations and earthing are labour-intensive for lines with multiple tees. While isolation is often done via motorised equipment, earthing is almost always done on-site through manually operated earth switches. Increasingly, practice is to use earth switches where possible; but, portable earths can still be used where earth switches are not available, for example when a line repair is required mid-circuit. If this is to occur at multiple sites (i.e. more than three), this becomes an onerous requirement on a TNSP and an inefficient use of resources. The manual

² A 'site' is defined as the location where the points of isolation at one end of a circuit are within the same terminal station. Only one suitably qualified person is required on that site to enable the safe, efficient and effective earthing, isolation and subsequent restoration of the circuit.

³ If the design of a substation is such that two circuit breakers of the same voltage are used to control a circuit (e.g. in a mesh-type substation), the two circuit breakers are to be considered as a single circuit breaker. This also applies where duplicate circuit breakers control a circuit, including those used for busbar selection. Circuit breakers connecting separate generating systems (such as several wind farms), or generating units (such as several large Gas Turbines) are to be considered separately.

⁴ National Grid Electricity Transmission plc. "National Electricity Transmission System Security and Quality of Supply Standard". Version 2.1, 7 March 2011.

application of either earth switches or portable earths is driven by Good Electricity Industry Practice (GEIP) with respect to the safety of personnel and equipment.

6.2 Site Expandability

6.2.1 Negotiated Single Connections

AEMO recognises that property development across Victoria can result in a low availability of land for new terminal stations, a high cost of purchase, or both when extending the DSN in densely populated areas. The land around existing terminal stations can become constrained, severely limiting expansion potential and restricting AEMO's ability to meet the requirements of a growing load and a greater penetration of generation. This issue is dealt with in AEMO's document, *Connecting Victoria: Transmission Project Development Protocol*.

Therefore, new connections to the DSN will require suitable land to accommodate the ultimate station configuration as identified in AEMO's long-term planning documents the National Transmission Network Development Plan and the Victorian Annual Planning Report and developed in accordance with its *Guidelines for Establishing Terminal Stations in Victoria*. If an applicant's connection triggers the development or augmentation of the footprint of a site, then any initial establishment must be developed in a manner consistent with development of the station up to the ultimate station configuration. This means that the arrangement of equipment on the site must allow for the ultimate station configuration to be built, if needed, and that the reliability of the connections to the site are not reduced.

Due to the difficulty in performing additional civil works once connection assets have been installed, the connection applicant may be required to provide sufficient land for the ultimate station configuration. The land should be levelled and drained to the extent that works to expand the station in the future do not impede the operation of existing assets or connection of new users to the DSN. The earth-grid should be established to allow safe operation while the site is partially realised, and be easily extended to cover the ultimate station configuration.

Therefore, if a connection applicant proposes to secure less land than would be required to fulfil this requirement, it would need to justify this to AEMO. In this case AEMO would still require the site to be laid out in a manner so as to be readily modified to a breaker-and-a-half connection in the future with a minimum of works. The site would also need to include an earthing system, installed so as to maintain step and touch potential to a safe level. At a minimum this will cover the initial arrangement, but should not be limited to this if earthing studies identify a potential issue or if construction issues at a later date would not allow safe extension of the earth-grid.

As the site is developed to the ultimate station configuration, the costs of purchasing land and preparing it to a suitable standard will be shared according to AEMO's Cost Allocation Policy in Victoria.

6.2.2 Sites Developed for Multiple Connections

As detailed in its *Guidelines for Establishing Terminal Stations in Victoria*, AEMO proposes to develop terminal stations to enable multiple connections in areas where there is a sufficient concentration of proposed generation or load developments in proximity to an existing transmission line. This seeks to minimise the overall cost of connection, reduce the number of transmission network connection points, and maintain or increase power system security.

AEMO requires that, where multiple connections are likely, terminal stations are developed in a manner that is consistent with the breaker-and-a-half arrangement. This is to ensure that outages to existing generation and the DSN are minimised when works are required to facilitate future connections.

Considerations, such as stability of the power system following a transmission fault, may require more secure connection arrangements. Further enhancement of the reliability of the breaker-and-a-half switching arrangement may therefore be considered on a case-by-case basis after AEMO undertakes more detailed analysis.

As detailed in Section 6.2.1 of these Guidelines, sufficient land will be required for the ultimate station configuration. The costs associated with purchasing and preparing the land will be shared across future connection applicants as they connect and in accordance with AEMO’s Cost Allocation Policy in Victoria.

AEMO does not intend to propose these stations as alternatives to the Australian Energy Market Commission’s (AEMC’s) Scale Efficient Network Extensions (SENEs) framework, but will endeavour to develop them in a manner consistent with any rule change that may eventuate from the AEMC’s SENEs framework consultations or similar processes.

6.2.3 Physical Connection

In all cases, where a new connection is to be made to an existing DSN transmission line, that line must be diverted into a terminal station switch bay. At a minimum, overhead lines may be diverted, landed and connected onto bus structures that are appropriate for the voltage level with appropriate isolation and earthing facilities. This may be the case where a connection other than the breaker-and-a-half standard has been agreed with AEMO.

An example of how this diversion could be achieved for the construction of a new terminal station, connecting to a single circuit of an existing double circuit line, is shown in Figure 6-1.

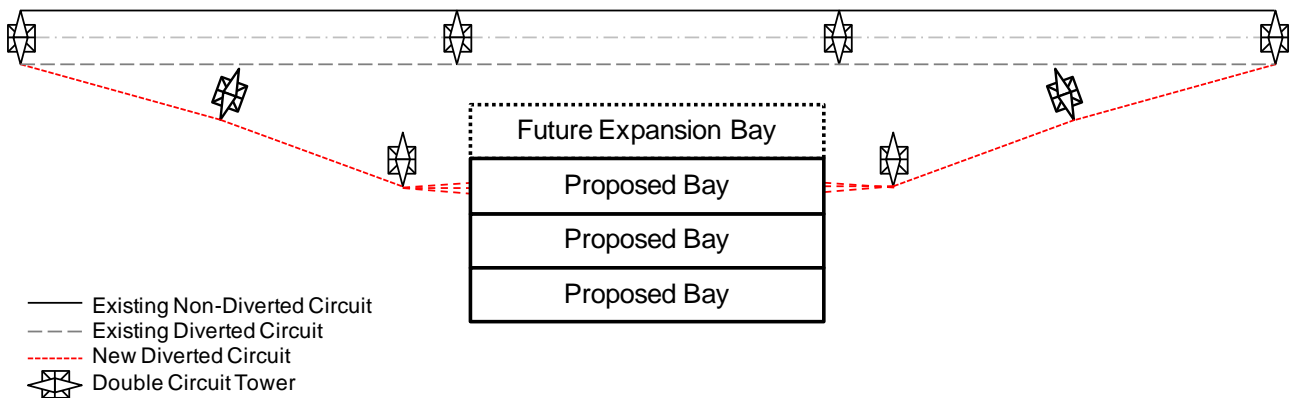

Figure 6-1: Line diversion example

The so called ‘hard tee’, made by connecting to the existing conductors of a 220 kV, 275 kV, 330 kV or 500 kV transmission line without breaking and diverting the line, does not meet the minimum requirements. The hard tee connection is therefore not an acceptable method of making a connection to the DSN. This is in keeping with considerations of maintainability and safety (Section 6.1 of these Guidelines) and site expandability, although practical considerations have also led to this position. Existing towers in the DSN are rarely able to accommodate the additional lateral loadings applied through a hard tee connection. Allowing this style of connection would therefore result in non-standard tower modification and stand-off structures being used. In addition the lack of any ability to reconfigure the connection means that there is a greater potential for longer periods of time where load is unable to be fed or generation is unable to contribute to the National Electricity Market (NEM). These factors are not in keeping with GEIP.

6.3 Protection

Any protection scheme established on existing lines as part of a new connection must be of at least the same performance, speed of operation and security as existing schemes for protection of the lines. There may be a need to increase the speed of protection operation if the connection reduces the critical clearing times in the area.

Optical Ground Wire (OPGW) is used in Victoria for differential protection relay communications. There may be a requirement to upgrade from existing Power Line Carrier (PLC) systems to OPGW in order to accommodate some new connections.

The process for determining a connection to the DSN (Section 5.1 of these Guidelines) provides for a connection applicant to demonstrate an alternative protection scheme that would support a connection arrangement that differs from the breaker-and-a-half arrangement. This alternative must provide equal or improved performance compared with the existing scheme. AEMO will consider the following when determining if this alternative is practicable:

- whether a consistent method of protection is applied across areas of the network;
- the degree to which the protection scheme meets the requirements of the Rules; and
- the impact of the upgrade on existing connections.

These considerations may therefore impose alterations to the proposed alternative protection scheme.

6.4 Regulatory and Other Issues

Connection modes of a lesser standard than the breaker-and-a-half may impact on the operator or TNSP discharging its responsibilities under the Rules, but more likely will impact other aspects of its business operations. The added management requirements around coordination of outages and dispatch of work teams to multiple sites, and the corporate reputation issues associated with outages (planned and unplanned), may be considerable.

6.5 Reliability of Shared Transmission Network

The reliability of major transmission lines, be they interconnectors between regions or significant intra-area transmission paths within regions, is critical to the efficient operation of the DSN and the NEM as a whole. AEMO's planning obligations will generally preclude the development of connections on these lines that reduce reliability. This is due to the effects that outages can have on the market, and the potential market volatility that can result from access at a lower performance level. In general, reduction in reliability and availability of the existing DSN and the impact on existing and future users should be minimised or avoided if possible.

7 Acceptability Criteria

On the basis of the considerations detailed in Section 6 of these Guidelines in specifying a connection to the DSN, AEMO will use the nine criteria described in this section to assess whether the connection may differ from the breaker-and-a-half configuration. Appendix A presents an assessment of several alternative connection arrangements against each of these criteria.

7.1 Complexity, Maintainability and Safety

- **Criterion 1:** When the connection is made in the alternative manner proposed, switching can still occur so that maintenance can be carried out in accordance with Clause S5.1.2.1(d) of the Rules⁵.
- **Criterion 2:** When the connection is made in the manner proposed, isolation and earthing of the entire line can be achieved by operation of equipment at no more than three sites.
- **Criterion 3:** When the connection is made in the manner proposed, isolation and earthing can be achieved by operation of no more than five circuit breakers.

⁵ The network service provider must ensure that all protection systems for lines at a voltage above 66 kV, including associated inter-tripping, are well maintained so as to be available at all times other than for short periods (not greater than eight hours) while the maintenance of a protection system is being carried out.

7.2 Site Expandability

- **Criterion 4:** Provision is to be made to accommodate the land requirements of the ultimate station configuration as determined by AEMO.
- **Criterion 5:** Sufficient connection equipment is to be installed at the initial connection stage to allow future expansion with:
 - minimal interruption to existing and future connected parties; and
 - no additional degradation in power transfer capability occurring, during expansion, above that which would exist if the initial connection had been made with a breaker-and-a-half layout.

7.3 Physical Connection

- **Criterion 6:** The proposed connection is made via a line diversion into the proposed new terminal station.

7.4 Reliability of Shared Transmission Network

- **Criterion 7:** The proposed connection does not cause a reduction in power transfer capability through the DSN.

7.5 Protection

- **Criterion 8:** The proposed protection and communications schemes meet the requirements of the Rules.
- **Criterion 9:** The connection arrangement allows consistent application of the existing protection and communications schemes with no degradation in performance, or the connection arrangement requires upgrade to either or both the existing protection and communications schemes to achieve no degradation in performance. If upgrades are required, they will form part of the connection works.

7.6 Technical Analysis under Schedules 5.2 and 5.3 of the Rules

Once all of the acceptability criteria have been assessed, reviewed and accepted by both AEMO and the connection applicant, AEMO will commence its assessment of the proposed connection against the requirements of Schedules 5.2 and 5.3 of the Rules where relevant. It is important to note that these assessments may identify issues that require a modification to the proposed connection arrangement if it does not comply with these requirements.

7.7 Potential Loss of Generation for a Credible Contingency

When considering the connection arrangement of generation projects to the DSN, AEMO will consider the capacity of generation that may be disconnected following a credible contingency event. AEMO will advise connection applicants on the acceptable limits of this capacity, and assess any proposed connection arrangements that differ from the standard against those limits.

Appendix A: Assessment of Alternative Connection Arrangements

This Appendix shows a series of arrangements for connecting to a single existing transmission line between Terminal Stations A and B. These arrangements are intended to represent proposals that connection applicants might put forward to AEMO for connection to the DSN. The series of arrangements is not intended to be exhaustive.

Diagrams of the arrangements are provided in Figures A–1 to A–8 as schematic representations of the various connection arrangements. Physical layouts of the equipment would need to be determined on a site-by-site basis and arranged so as not to impede development up to the final layout. To simplify the examples, double line connection arrangements are not shown, although the same criteria should be applied to these connections.

Table A-1 presents the likely assessment outcomes for each of the connection arrangements against the criteria presented in Section 7 of these Guidelines for connection to the DSN. Note that many of these arrangements are unlikely to satisfy all criteria and so would not normally be acceptable.

Configuration	Criteria								
	1	2	3	4	5	6	7	8	9
Hard tee – No CBs	N	N	Y	N/A	N	N	SD	N	N
Hard tee – 1 CB	N	Y	Y	N/A	N	N	SD	SD	SD
Soft tee – 1 CB	SD	Y	Y	N/A	N	Y	SD	SD	SD
Single-busbar – 3 CBs	SD	Y	Y	N/A	N	Y	SD	SD	SD
Main and transfer busbar	SD	Y	Y	N/A	N	Y	SD	SD	SD
Ring busbar	SD	Y	Y	N/A	N	Y	SD	SD	SD
Breaker-and-a-half	SD	Y	Y	N/A	Y	Y	SD	SD	SD
Double-busbar	SD	Y	Y	N/A	Y	Y	SD	SD	SD

NOTE: Y = Acceptable
 N = Not Acceptable
 N/A = Not Applicable
 SD = Site Dependent

Table A-1: Alternative connection arrangements against acceptability criteria

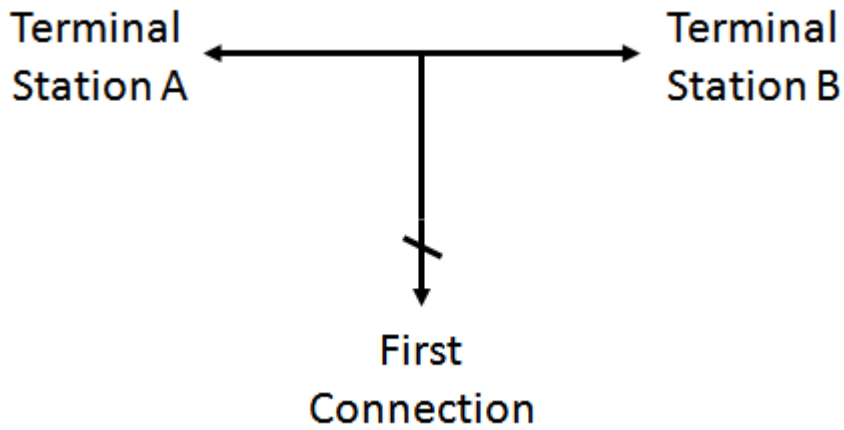

Figure A-1: Hard tee – no breakers

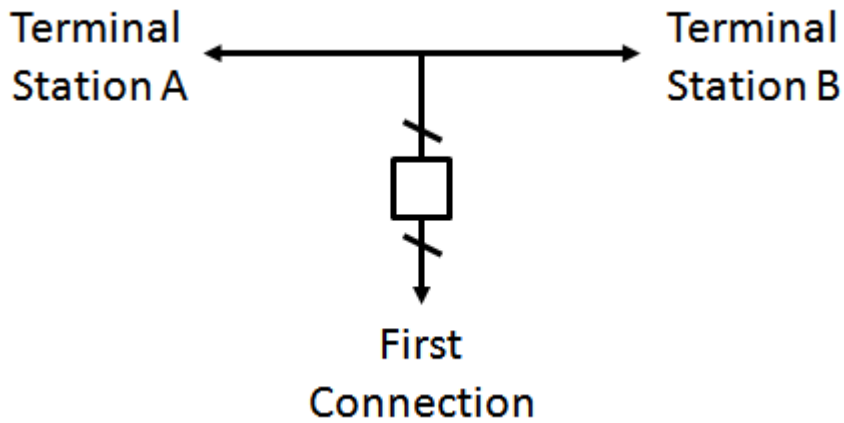

Figure A-2: Hard tee – with a breaker

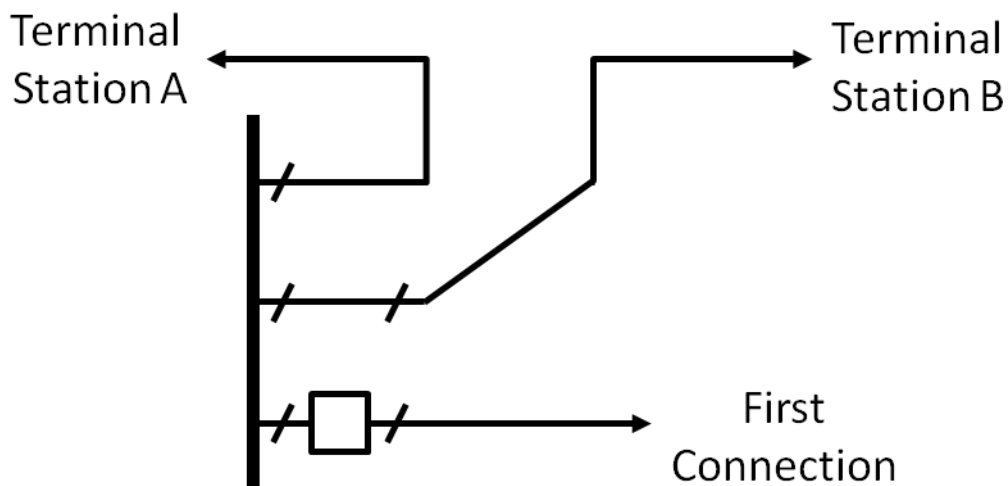

Figure A-3: Soft tee – with a breaker

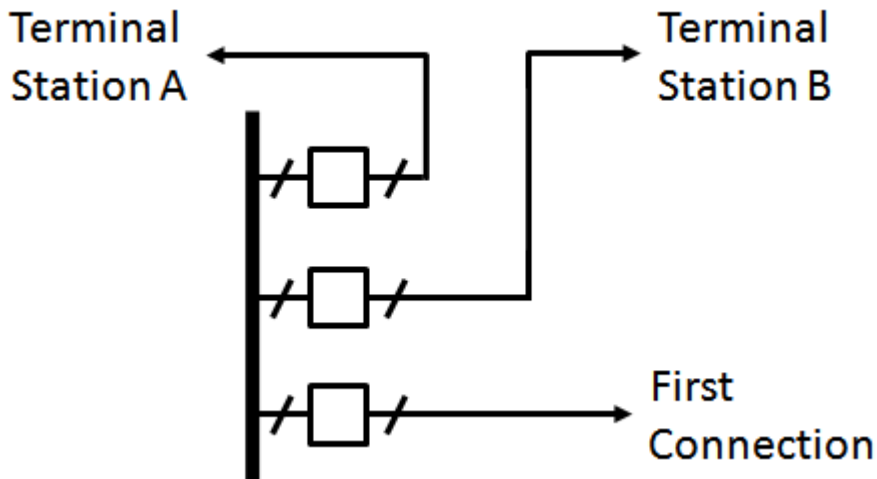

Figure A-4: Single-busbar

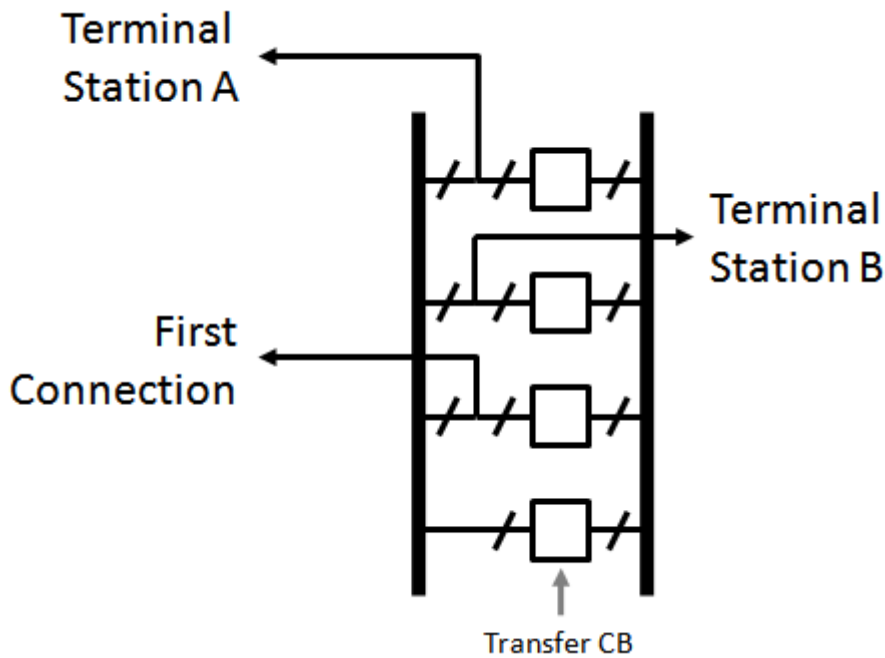

Figure A-5: Main and transfer busbar

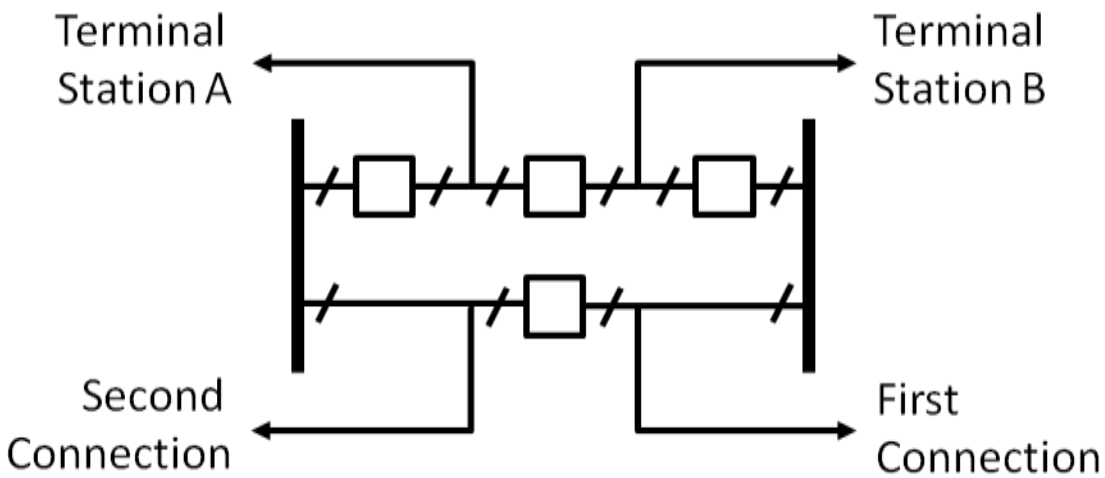

Figure A-6: Ring busbar

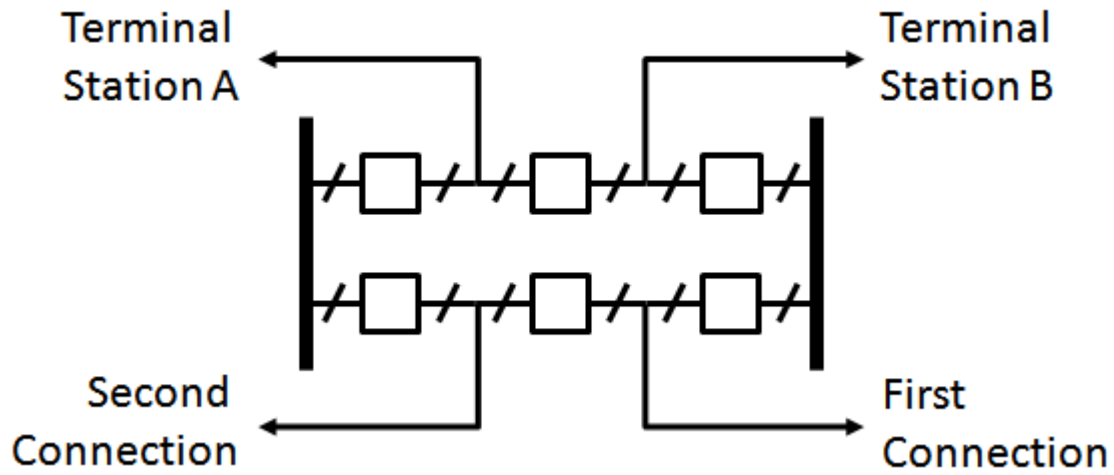

Figure A-7: Breaker-and-a-half

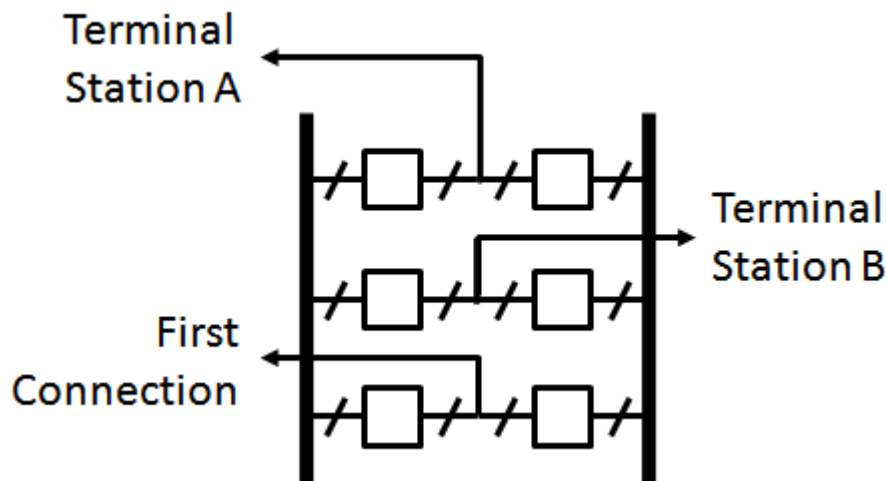

Figure A-8: Double-busbar, double-breaker