

## APPLICATIONS

- Suburban Roads
- Driveways
- School Grounds
- Pathways
- Shopping Malls
- Parklands

# BOSTON SE & TE

Traditional shape lanterns for traditional suburban streets, urban areas and streetscapes. The lantern reflector design eliminates unwanted upward light, providing higher lumination at ground level.

## Dimensions

A Spigot as per AS/NZS1158

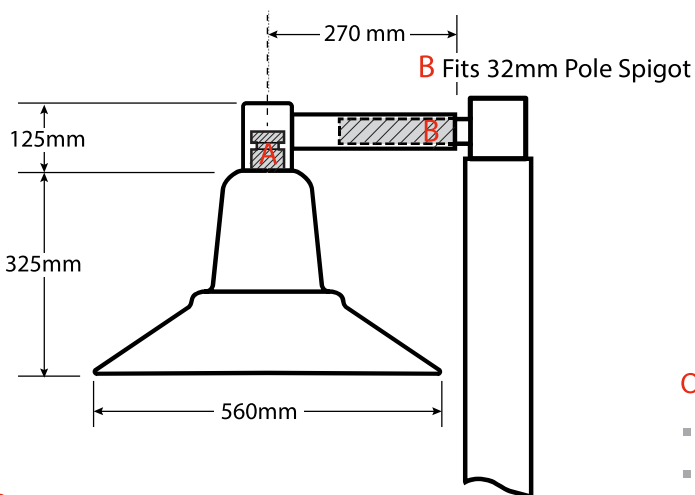

## Features

- Designed to meet stringent Australian Standards
- Self cleaning housing and PMMA optical diffuser
- High Performance LED and Optics to meet AS/NZ1158
- Integrated thermal management
- Hinged 'quick access latch'
- Complies with AS/NZ 1158.6 & AS/NZ 1158.1
- 10 year warranty

## Options

- Photocell: 7-pin Nema receptacle (7PN)
- Fuse Terminal Block: (FTB)
- Surge Protection Device: (SPD - 10KVA, 20KVA)
- Class II: (DB - Double Insulated)
- Colour: Green (GR), Black (BK-Standard)
- CCT: 3000K, **4000K (Standard)**, 5000K
- Visor: Glareshield/spill light kit (GV)

## Technical Data

- Body:** High Pressure Marine Grade Die Cast Aluminum
- Optics:** P4 & P5 Distribution
- Wattage:** 15 - 17 - 23 - 30 Watts
- Finishing:** Powder Coat Black (Standard)
- Mounting:** 4 - 9 Metres
- Fixing:** Fits 32mm Pole Spigot
- IP rating:** IP66
- IK rating:** IK06
- Voltage:** 220 - 240V 50/60Hz
- Power Factor:** >0.9

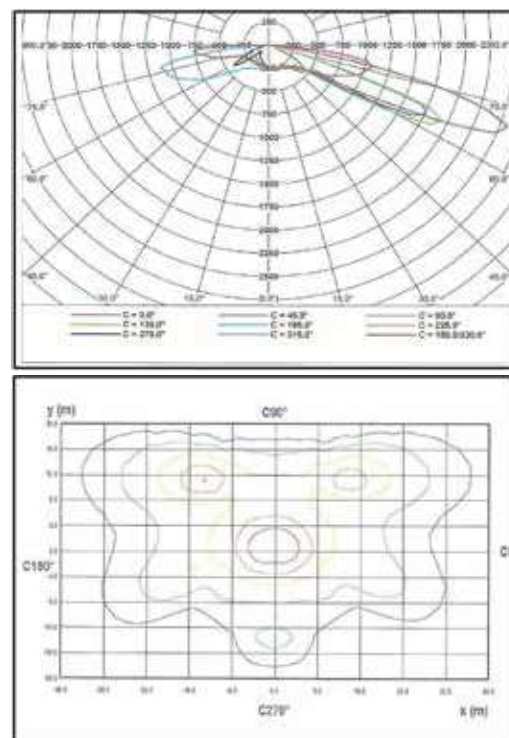

## Specification BOSTON-SE - Side Entry

PRODUCT CODE	BOS2.TE.515	BOS2.TE.514	BOS2.TE.520	BOS2.TE.530
Photometric Distribution	P4 - P5	P4 - P5	P4 - P5	P4 - P5
Power Watts (W)	15W	17W	23W	30Wncv8
Input Voltage (V)	220V - 240V 50/60Hz	220V - 240V 50/60Hz	220V - 240V 50/60Hz	220V - 240V 50/60Hz
CCT (K)	3000K/ 4000K/ 5000K	3000K/ 4000K/ 5000K	3000K/ 4000K/ 5000K	3000K/ 4000K/ 5000K
CRI (Ra)	Ra>80	Ra>80	Ra>80	Ra>80
IP Protection	IP66	IP66	IP66	IP66
IK Protection	IK06	IK06	IK06	IK06
Weight (Kg)-max.	15kg	15kg	15kg	15kg

Dimensions

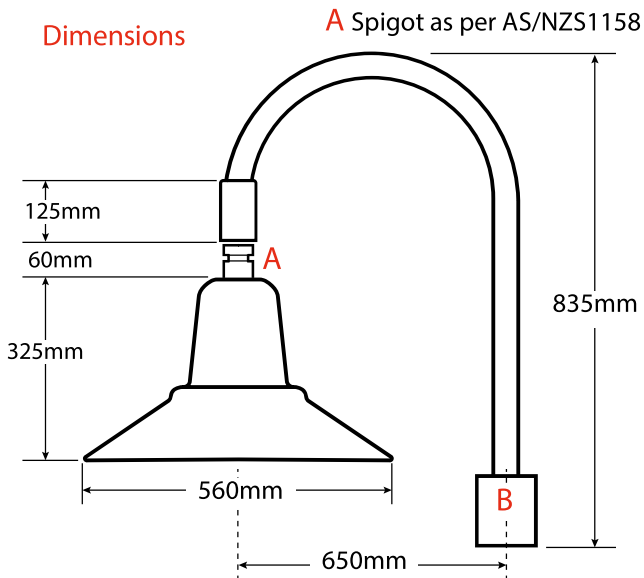

Features

- Designed to meet stringen
- Self cleaning housing and PMMA optical diffuser
- High Performance LED & Optics to meet AS/NZ1158
- Integrated thermal management
- Hinged 'quick access latch'
- Complies with AS/NZ 1158.6 & AS/NZ 1158.1
- 10 year warranty

Options

- **Photocell:** 7-pin Nema receptacle (7PN)
- **Fuse Terminal Block:** (FTB)
- **Surge Protection Device:** (SPD - 10KVA, 20KVA)
- **Class II:** (DB - Double Insulated)
- **Colour:** Green (GR), Black (BL-Standard)
- **CCT:** 3000K, **4000K (Standard)**, 5000K
- **Visor:** Glareshield/spill light kit (GV)



Technical Data

- **Body:** High Pressure Marine Grade Die Cast Aluminum
- **Optics:** P4 & P5 Distribution
- **Wattage:** 15 - 17 - 23 - 30 Watts
- **Finishing:** Powder Coat Black (Standard)
- **Mounting:** 4 - 9 Metres
- **Fixing:** Fits 32mm Pole Spigot
- **IP rating:** IP66
- **IK rating:** IK06
- **Voltage:** 220 - 240V 50/60Hz
- **Power Factor:** >0.9

Photometric Design Data

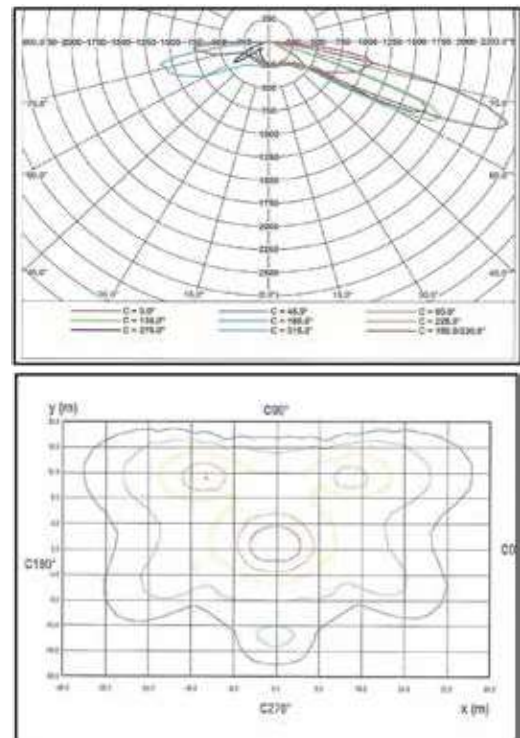

Specification BOSTON-TE - Top Entry

PRODUCT CODE	BOS2.TE.515	BOS2.TE.514	BOS2.TE.520	BOS2.TE.530
Photometric Distribution	P4 - P5	P4 - P5	P4 - P5	P4 - P5
Power Watts (W)	15W	17W	23W	30W
Input Voltage (V)	220V - 240V 50/60Hz	220V - 240V 50/60Hz	220V - 240V 50/60Hz	220V - 240V 50/60Hz
CCT (K)	3000K/ 4000K/ 5000K	3000K/ 4000K/ 5000K	3000K/ 4000K/ 5000K	3000K/ 4000K/ 5000K
CRI (Ra)	Ra>80	Ra>80	Ra>80	Ra>80
IP Protection	IP66	IP66	IP66	IP66
IK Protection	IK06	IK06	IK06	IK06
Weight (Kg)-max.	15kg	15kg	15kg	15kg

