

GUIDE TO MIS-PRICING INFORMATION RESOURCE

PREPARED BY: Electricity Market Performance

VERSION: 2.0

DATE: 27 October 2011

Contents

1	Introduction	5
2	Mis-Pricing: General Definition.....	5
3	Mis-Pricing: Calculation.....	6
4	Terminology and Definitions for Information Provided.....	7
4.1	Hours of Mis-Pricing per Connection Point	7
4.2	Average Duration of Mis-Pricing per Region.....	7
4.3	Average Amount of Mis-Pricing per Connection Point	8
4.4	Average Amount of Mis-Pricing per Region	8
4.5	Positive Mis-Pricing	8
4.6	Negative Mis-Pricing	9
4.7	Mis-Pricing under System Normal Conditions.....	9
4.8	Mis-Pricing under Outage Conditions	9
5	Scope of Mis-Pricing Information	9
5.1	Graphical sets provided.....	9
5.2	Examples of graphs.....	10
5.3	Regional Comparison Graphs	10
5.3.1	NEM - Quarterly Comparison.....	13
5.3.2	Region Specific – Quarterly Comparison	16
5.3.3	Regional per Connection Point	20
6	References.....	23
7	Appendix A.....	24
8	Appendix B.....	25

Disclaimer

This document is made available to you on the following basis:

- (a) **Purpose** – *This Guide to Mis-Pricing Information Resource (**Guide**) has been produced by the Australian Energy Market Operator Limited (**AEMO**) to provide information about the Mis-Pricing Information Resource as at the date of publication.*
- (b) **No substitute** – *This Guide is not a substitute for, and should not be read in lieu of, the National Electricity Law (**NEL**), the National Electricity Rules (**Rules**) or any other relevant laws, codes, rules, procedures or policies. Further, the contents of this Guide do not constitute legal or business advice and should not be relied on as a substitute for obtaining detailed advice about the NEL, the Rules, or any other relevant laws, codes, rules, procedures or policies, or any aspect of the national electricity market or the electricity industry.*
- (c) **No Warranty** – *While AEMO has used due care and skill in the production of this Guide, neither AEMO, nor any of its employees, agents and consultants make any representation or warranty as to the accuracy, reliability, completeness or suitability for particular purposes of the information in this Guide.*
- (d) **Limitation of liability** - *To the extent permitted by law, AEMO and its advisers, consultants and other contributors to this Guide (or their respective associated companies, businesses, partners, directors, officers or employees) shall not be liable for any errors, omissions, defects or misrepresentations in the information contained in this Guide, or for any loss or damage suffered by persons who use or rely on such information (including by reason of negligence, negligent misstatement or otherwise). If any law prohibits the exclusion of such liability, AEMO's liability is limited, at AEMO's option, to the re-supply of the information, provided that this limitation is permitted by law and is fair and reasonable.*

© 2010 - All rights reserved.

Purpose of this Document

Information on historical incidences of mis-pricing can improve the ability of market participants to manage risks resulting from congestion on the transmission network. Information on historical mis-pricing trends can assist in identifying the significance of intra-regional congestion in the National Electricity Market (NEM).

AEMO is obligated by the National Electricity Rules to publish an analysis on the extent and pattern of mis-pricing caused by congestion. The information published will meet the requirement of Rule 3.7A(b):

To implement the congestion information resource objective, AEMO must develop and publish, in accordance with this rule 3.7A, an information resource comprising:

(2) historical data on mis-pricing at transmission network nodes in the national electricity market.

AEMO will publish mis-pricing information within the time frames stipulated in the Spot Market Operations Timetable, published at

<http://www.aemo.com.au/electricityops/108-0029.html>

This document and the information that is published for market participants do not attempt to measure the potential economic impact of mis-pricing on the NEM. It simply provides historical information regarding the frequency and duration of mis-pricing in the market.

The information provided in the document focuses on the number of connection points affected by mis-pricing, the duration of the mis-pricing (in hours) and the mis-pricing amount (in \$/MWh). The information is supplied at connection point level for the separate regions in the NEM. Aggregated information is also provided per region across five consecutive quarterly intervals, to allow for the recognition of both inter-regional trends and trends over time. Distinctions are further made between system normal conditions and outage conditions, and between positive and negative mis-pricing.

More constraint information can be found on the AEMO website:

- Constraint Naming Guidelines, published at www.aemo.com.au/electricityops/200-0141.html
- Generic Constraints due to Network Limitations, published at <http://www.aemo.com.au/electricityops/3709.html>
- The Network Outage Schedule, published at <http://www.aemo.com.au/planning/NOS.html>

Participants should note that this document is intended as a guide to interpret mis-pricing trends only. The document and quarterly published graphs should not be used to assist in business decisions as several assumptions were made (detailed in Section 3).

1 Introduction

In an electricity market, the price for electricity will vary across different locations on the network due to losses and the presence of binding transmission constraints or “network congestion”. The NEM allows for a degree of price separation by calculating and publishing five locational prices, one in every geographic region or state (known as the Regional Reference Price or RRP). This practice forces prices within a region to be the same (ignoring marginal loss factors), effectively ignoring the effect of transmission constraints on prices at the different connection points within a region – the RRP may reflect this effect by being higher or lower than it would be without the congestion, but the price separation is not reflected intra-regionally.

Congestion causes divergences between the RRP and local nodal prices in the NEM. This impact is not reflected in differences in the prices paid or received by participants located at those other nodes in the region. As noted above, all generators (and loads) within a region receive (and pay) the same price (the RRP) for the energy they are dispatched to produce (and consume) within a trading interval regardless of whether their implied local nodal price is the same as their RRP. This disjunction between the implied nodal prices yielded by the dispatch process and the RRP used for settlement is commonly referred to as “mis-pricing”. Mis-pricing can create risks for participants and promote behaviours that reduce economic efficiency.

Generators do not have an incentive to offer their generation to the market at the true marginal cost, and may revert to other strategies to ensure that they are dispatched or decommitted. These strategies may affect the short term efficiency of the dispatch process.

In the longer term economic signals for investment at different locations on the network are weakened. This may affect investment decisions by generators and large industrial and commercial users about where to invest in transmission and/or generation. Generators and large loads may therefore locate at a point which exacerbates congestion, or alternatively may not be aware of opportunities to invest in a location which may alleviate congestion problems.

2 Mis-Pricing: General Definition

The term “Mis-pricing” is used to describe the deviation in the “local” or “nodal” price at each generator connection point from the regional reference price in the same region, due to the presence of network congestion.

Mis-pricing occurs when the dispatched energy of a generator is directly subjected to a binding constraint equation. The local price may be higher or lower than the relevant RRP. Positive mis-pricing occurs when the local price is lower than the RRP, as is shown in Appendix A. Negative mis-pricing occurs when the local price is higher than the RRP, as is shown in Appendix B.

If the local price at a given location varies often and significantly from the relevant RRP, the problem of intra-regional congestion may be significant.

For the purpose of this document and the mis-pricing information that AEMO provides, mis-pricing will only refer to generator connection points. Load connection points do not normally appear on the left-hand side of constraint equations, and it is therefore not possible to determine whether a load connection point is subjected to mis-pricing.

3 Mis-Pricing: Calculation

The mis-pricing calculation described in this section applies to “general” or the usual pricing conditions only. In some cases, e.g. when over-constrained dispatch occurs or administered price caps are in place, some adjustments will be made. These adjustments will not change the formulas, but may have an impact on the values of the inputs.

The mis-pricing calculation uses 5-minute dispatch data. The calculated mis-pricing value is based on the product of the coefficient of the generator term in the constraint equation’s left-hand side and the marginal value of the constraint equation¹ (this marginal value is zero when the constraint is not binding). If the generator term appears in more than one binding constraint for a given dispatch interval, the mis-priced values are summed for all constraints.

Mathematically (ignoring losses), the local price at connection point i can be written as:

$$LocalPrice_i = RRP + \sum_n (k_i^n \times MV^n)^2 \quad (1)$$

where

$LocalPrice_i$ is the local or nodal price at connection point i
 RRP is the regional reference price at the regional reference node, associated with connection point i
 k_i^n is the coefficient of the i^{th} connection point in the n^{th} binding constraint
 MV^n is the marginal value of the n^{th} binding constraint.

The mis-pricing amount at connection point i is defined as

$$MPA_i = - \sum_n (k_i^n \times MV^n) = RRP - LocalPrice_i \quad (2)$$

therefore $LocalPrice_i = RRP - MPA_i$. (2b)

Assume that energy prices in the NEM are bound by a market floor price of -\$1000/MWh and a market price cap of \$12500/MWh³. It follows that

$$-\$1000 \leq LocalPrice_i \leq \$12500$$

i.e. from (2b) $-\$1000 \leq RRP - MPA_i \leq \12500 ,

implying that the mis-pricing amounts are always bounded by

$$-\$1000 - RRP \leq -MPA_i \leq \$12500 - RRP$$

i.e. $-\$12500 + RRP \leq MPA_i \leq \$1000 + RRP$.

¹ For the purpose of mis-pricing, only binding **network constraints** are considered. Constraints that are not considered as contributing to price separation include

- FCAS constraints
- Quick constraints created to deal with non-conformance of generators
- Constraints invoked under Network Support Agreements between Transmission Network Service Providers and market participants.

² The National Electricity Market Dispatch Engine (NEMDE) minimises the supply cost subject to constraints. The marginal cost of the constraint is defined as $\frac{\partial OF}{\partial RHS}$, which is the change in objective function (OF) for a marginal change in the Right Hand Side (RHS) of the constraint.

If the constraint type is LHS \leq RHS, an increase in the RHS will relax the constraint, decreasing the OF so that the MV of the constraint is negative. If LHS \geq RHS, an increase in the RHS will tighten the constraint, increasing the OF so that the MV of the constraint is positive.

³ Ignoring the impact of loss factors.

Since it is also true that $-\$1000 \leq RRP \leq \12500 , the mis-pricing amount at any connection point i will be bound by

$$-\$12500 + (-\$1000) \leq MPA_i \leq \$1000 + (\$12500)$$

i.e. $-\$13500 \leq MPA_i \leq \13500 .

4 Terminology and Definitions for Information Provided

Information will be supplied at connection point level and at regional level.

The formulas and definitions provided in sections 4.1 to 4.8 are used in the document “Mis-Pricing due to Network Congestion”, published quarterly by AEMO.

Data is provided for the number of connection points affected by mis-pricing, the hours of mis-pricing per connection point and the average mis-pricing amount per connection point (in \$/MWh), as defined in Sections 4.1 and 4.3.

Similar aggregated data is then provided at regional level, i.e. the average time a connection point in region R was subjected to mis-pricing (in hours) and the associated average mis-pricing amount of a typical connection point in region R (in \$/MWh). Sections 4.2 and 4.4 provide the relevant definitions for these two situations.

The dispatch process can clear a marginal energy offer *higher* than the *RRP*, but the generator only gets paid the *RRP*. This will typically occur when a generator is constrained-on. Similarly the dispatch process may not clear an offer below the *RRP*. This will typically occur when a generator is constrained-off. Sections 4.5 and 4.6 provide the relevant definitions for these two situations.

In order to identify the “base line” power system congestion without system outages, mis-pricing information will also be provided for “system normal “ conditions and for “system outage” conditions separately, as per the definitions in Section 4.7 and 4.8.

4.1 Hours of Mis-Pricing per Connection Point

The **hours of mis-pricing at connection point i** is calculated by taking the sum of all the dispatch intervals where connection point i was mis-priced and expressing this time value in terms of hours. The hours of mis-pricing is displayed only for connection points where the hours of mis-pricing exceed a specific threshold (in hours).

4.2 Average Duration of Mis-Pricing per Region

The average number of hours a typical connection point in a region was mis-priced, is defined as the **average duration of mis-pricing for a given region R** and is calculated as

$$\frac{\sum_{i=1}^n (\text{hours of mis-pricing at connection point } i)}{n}$$

where n is the number of all **mis-priced connection points** in region R.

The average duration of mis-pricing is only displayed for connection points where the hours of mis-pricing exceed a specific threshold (in hours).

4.3 Average Amount of Mis-Pricing per Connection Point

The **average amount of mis-pricing at connection point i** is calculated as

$$\frac{\sum_{t=1}^{T_i} (MPA_{i,t})}{T_i}$$

where $MPA_{i,t}$ = the mis-pricing amount in \$/MWh at connection point i at time t and

T_i is the number of dispatch intervals during which connection point i was mis-priced.

4.4 Average Amount of Mis-Pricing per Region

The average amount with which a typical connection point in a region is mis-priced per dispatch interval, is defined as the **average amount of mis-pricing for a given region R** and is calculated as

$$\frac{\sum_{i=1}^n \left(\sum_{t=1}^{T_i} \frac{MPA_{i,t}}{T_i} \right)}{n}$$

where $MPA_{i,t}$ = the mis-pricing amount in \$/MWh at connection point i at time t ,

T_i is the number of dispatch intervals during which connection point i was mis-priced and

n is the number of all mis-priced connection points in region R .

4.5 Positive Mis-Pricing

Positive mis-pricing occurs when $MPA_i > 0$.⁴

From equation (2) it follows that

$$RRP - LocalPrice_i > 0$$

or alternatively

$$RRP > LocalPrice_i .$$

In this case there is generation available, offered at less than the RRP which was not cleared in the dispatch process. This will typically occur when a generator is constrained-off.

⁴ Refer to Appendix A for a numerical example.

4.6 Negative Mis-Pricing

Negative mis-pricing occurs when $MPA_i < 0$.⁵

From equation (2) it follows that

$$RRP - LocalPrice_i < 0$$

or alternatively $RRP < LocalPrice_i$.

In this case the dispatch process cleared a marginal energy offer *higher* than the *RRP*, but the generator only gets paid the *RRP* . This will typically occur when a generator is constrained-on.

4.7 Mis-Pricing under System Normal Conditions

Mis-pricing events may occur when a generator is constrained by system normal constraints. The set of constraint equations reflecting a network configuration in the absence of any outages is referred to as a set of system normal constraints. These constraints are always applied in NEMDE.

4.8 Mis-Pricing under Outage Conditions

Mis-pricing events may occur when a generator is constrained by network outage constraints or reclassification constraints. It is necessary for AEMO to build additional network outage constraints to manage system security due to the occurrence of unusual network outage configurations.

5 Scope of Mis-Pricing Information

The following section lists the scope of the mis-pricing information that is provided.

5.1 Graphical sets provided

Four sets of information are included. The first set is the **Regional Comparison** graphs. The set contains three graphs showing regional mis-pricing trends over time. The second set is the **NEM Quarterly Comparison** graphs. The set contains six graphs showing mis-pricing information for the NEM over time. The third set of graphs is the **Region Specific – Quarterly Comparison** set. The set contains six graphs for each region in the NEM, encompassing 30 graphs in total. The last set is the **Regional per Connection Point: Current Quarter** graphs, where mis-pricing information is provided at connection point level, but for the most recent quarter only. This set contains 30 graphs, i.e. six graphs for each region in the NEM.

- The first set of results show the number of connection points where mis-pricing occurred, the average dollar value (amount) of the mis-pricing and the average time (duration) mis-pricing occurred for. Data is provided for all regions in one graph, across a five-quarter time frame. This allows for trend comparison across time and region.
- The second set of results provides mis-pricing for the NEM as a whole. The first 3 graphs provide the average amount of mis-pricing. The last 3 graphs focus on the average duration of mis-pricing across

⁵ Refer to Appendix B for a numerical example.

all mis-priced connection points. Information is displayed for five quarters, which allows for trend comparison over time.

- The third set of results is similar to those of the second set, but information is given for each region separately for five consecutive quarters. For illustrative purposes the information in this document is for Queensland only.
- The fourth set of results provides mis-pricing information at connection point level. The average number of hours a connection point was mis-priced for is given for the last quarter. The average amount of mis-pricing per connection point is also provided per region, for the latest quarter. The information is provided for every region separately, but for indicative purposes the information in this document is for New South Wales only.

With the exception of the Regional Comparison Graphs (Figures 1.1, 1.2 and 1.3 in section 5.2) which provide trends between the regions over time, every set of mis-pricing information is displayed in three ways:

- The relevant mis-pricing information (exceeding the threshold values, where specified)
- The relevant mis-pricing information, plotted separately for positive and negative mis-pricing⁶
- The relevant mis-pricing information, plotted for system normal conditions and for outage conditions, i.e. where outage constraints were in place.

The published graphs can be used to answer questions such as:

- How many connection points are affected in every region?
- How often does each connection point price differ from the relevant regional reference price?
- How large is the deviation of the local price from the regional reference price (mis-pricing amount)?
- Is the situation worse in some regions than others?
- Is the situation improving, or getting worse over time?
- Are more connection points affected during network outages?

5.2 Examples of graphs

This section contains examples of the graphs provided in the quarterly publication “Mis-Pricing due to Network Congestion”. The information in sections 5.2.1 to 5.2.3 is provided for five consecutive quarters.

For easy reference, the numbering of the graphs in the guide corresponds to the numbering of the published graphs.

5.3 Regional Comparison Graphs

This section provides mis-pricing information for all the regions and the NEM, as listed below:

- The total number of connection points affected by mis-pricing, given for each region (Figure 1.1).
- The average dollar value per mis-priced connection point, given for each region (Figure 1.2).
- The average time that a connection point was mis-priced for, for each region (Figure 1.3).

⁶ When a generator is subjected to multiple binding constraints during a review period, positive and negative mis-pricing amounts may off-set each other, thereby masking the overall mis-pricing effect. It was therefore decided to also provide mis-pricing information where this distinction was made.

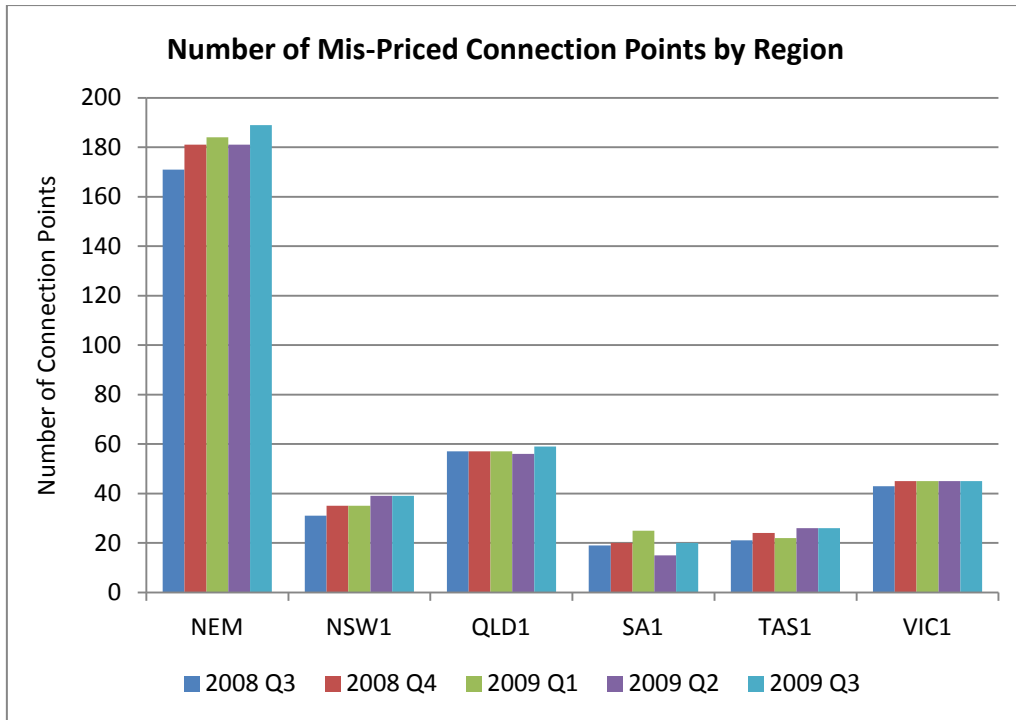

Figure 1. 1 All Regions: Number of mis-priced connection points

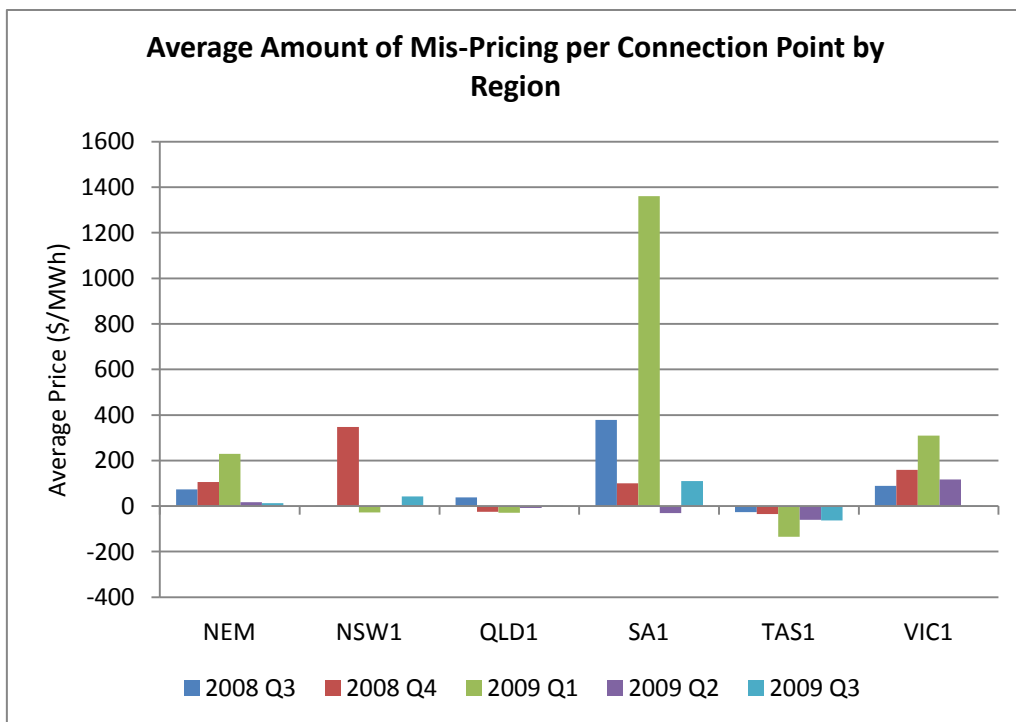

Figure 1. 2 All regions: Average amount of mis-pricing

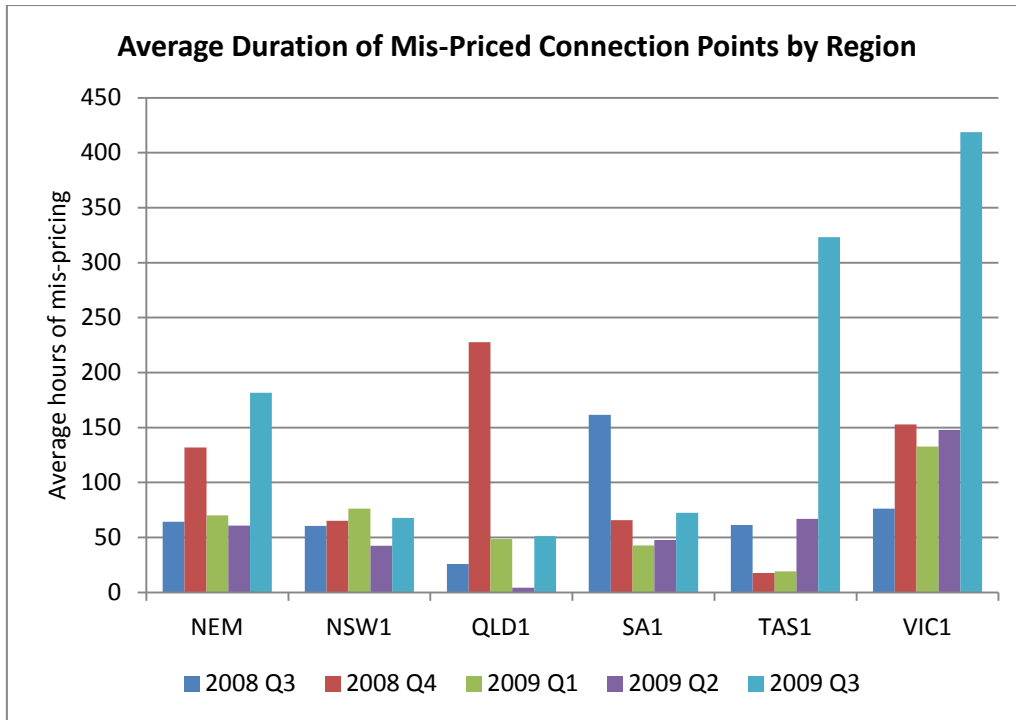

Figure1. 3 All Regions: Average duration of mis-pricing

5.3.1 NEM - Quarterly Comparison

The section NEM - Quarterly Comparison provides mis-pricing information for the NEM regions combined. The information includes the total number of mis-priced connection points, the average amount (\$/MWh) of mis-pricing per typical connection point and the average time (duration) a connection point was mis-priced, as listed below:

- The number of mis-priced connection points and the average amount of mis-pricing (Figure 2.1).
- The number of mis-priced connection points and the average positive and negative mis-pricing amounts (Figure 2.2).
- The number of mis-priced connection points and the average mis-pricing amount, with the distinction made between mis-pricing incurred during system normal conditions and during outage conditions (Figure 2.3).
- The number of mis-priced connection points and the average duration mis-pricing occurred for (Figure 2.4).
- The number of mis-priced connection points and the average duration mis-pricing occurred for, with the distinction made between positive mis-pricing and negative mis-pricing (Figure 2.5).
- The number of mis-priced connection points and the average duration mis-pricing occurred for, with the distinction made between mis-pricing incurred during system normal conditions and during outage conditions (Figure 2.6).

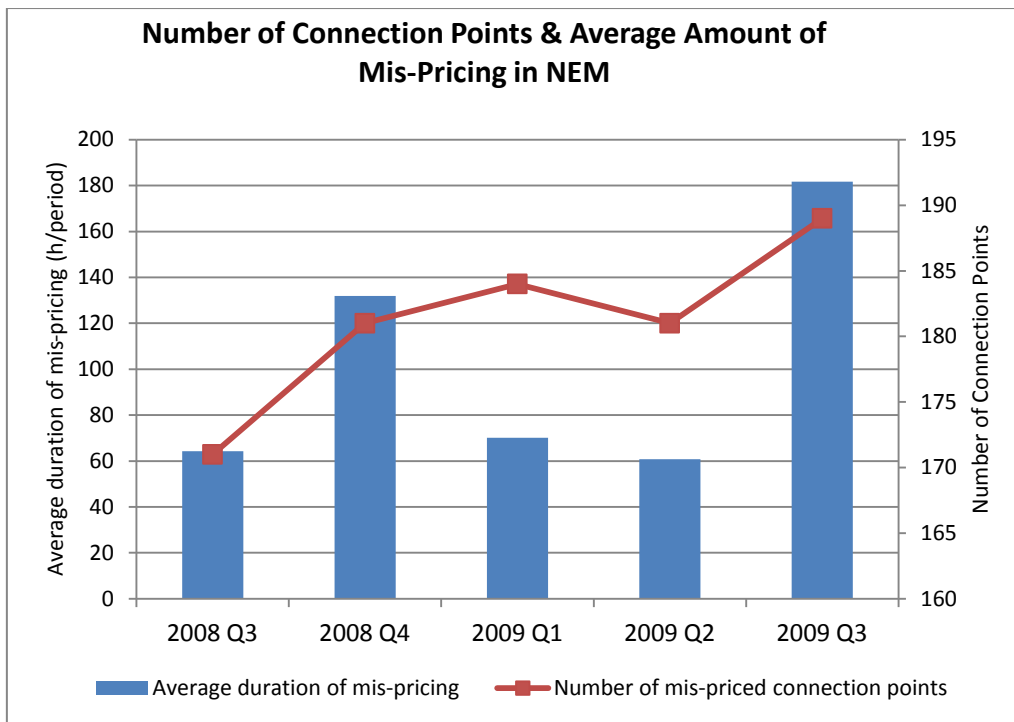

Figure 2. 1 NEM: Number of mis-priced connection points and average amount of mis-pricing

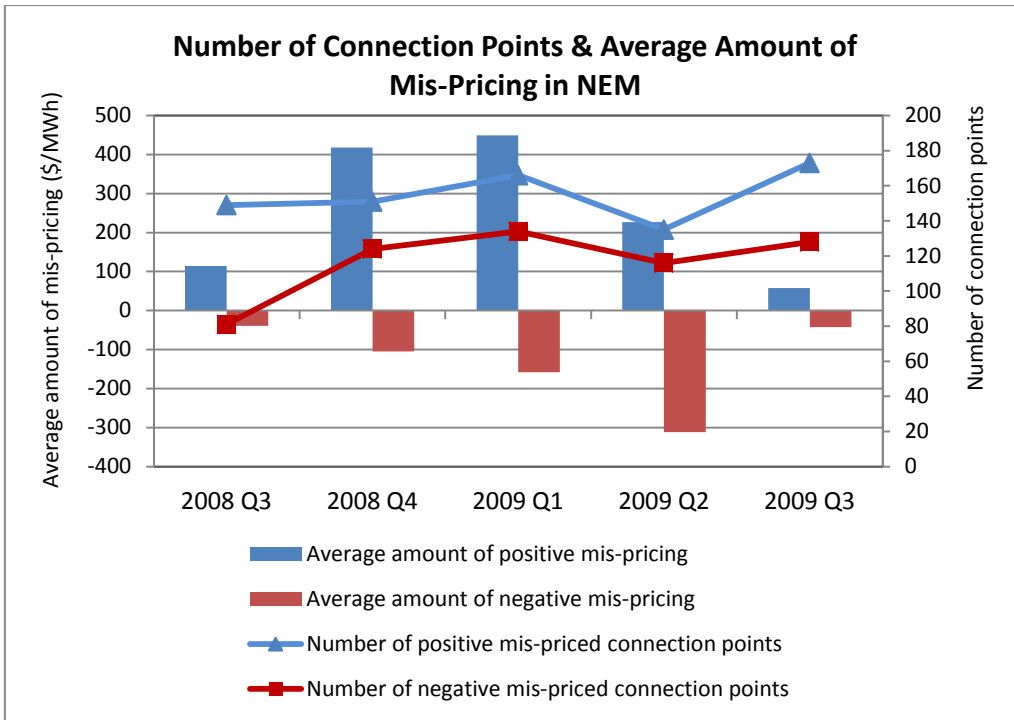

Figure 2. 2 NEM: Number of mis-priced connection points and average amount of mis-pricing - Positive and Negative Mis-Pricing

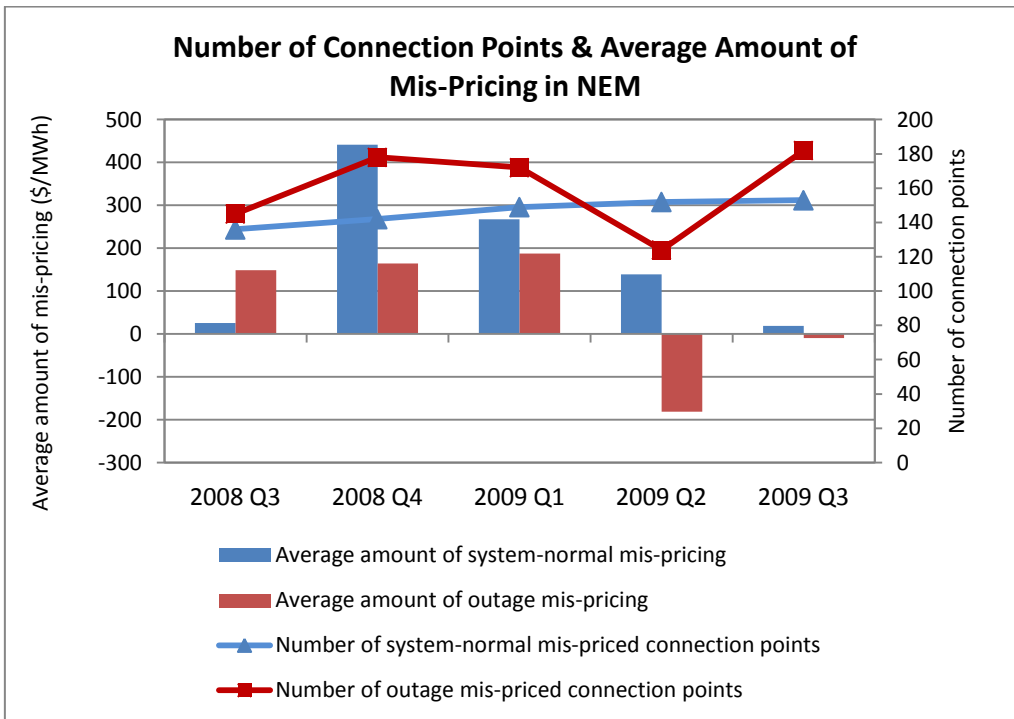

Figure 2. 3 NEM: Number of mis-priced connection points and average amount of mis-pricing - System Normal and Outage

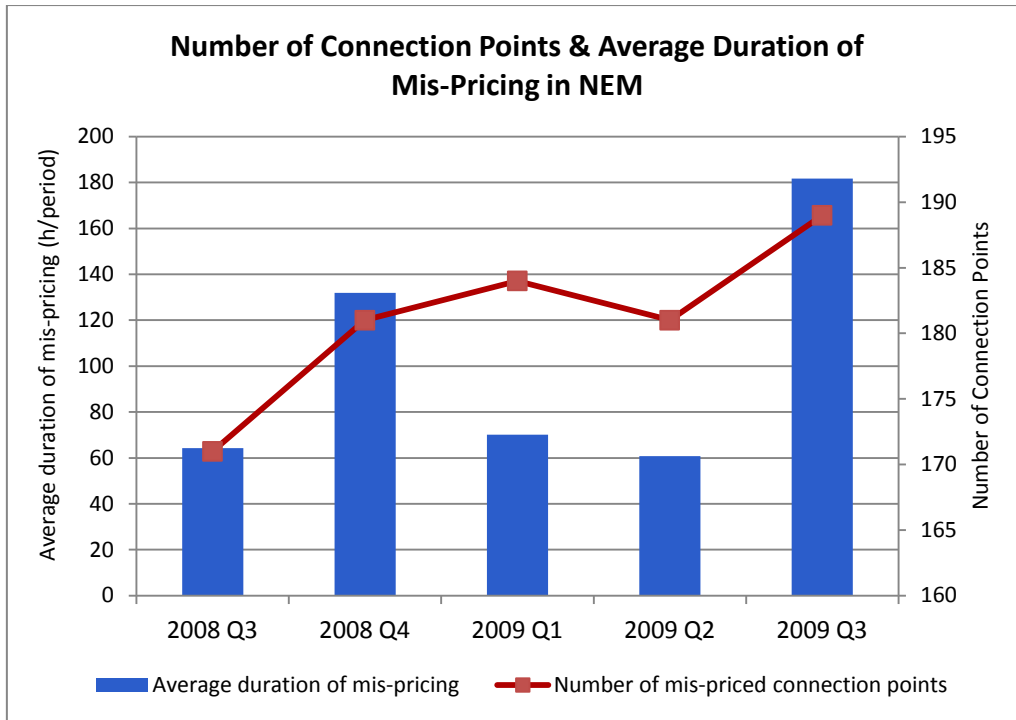

Figure 2. 4 NEM: Number of mis-priced connection points and average duration of mis-pricing

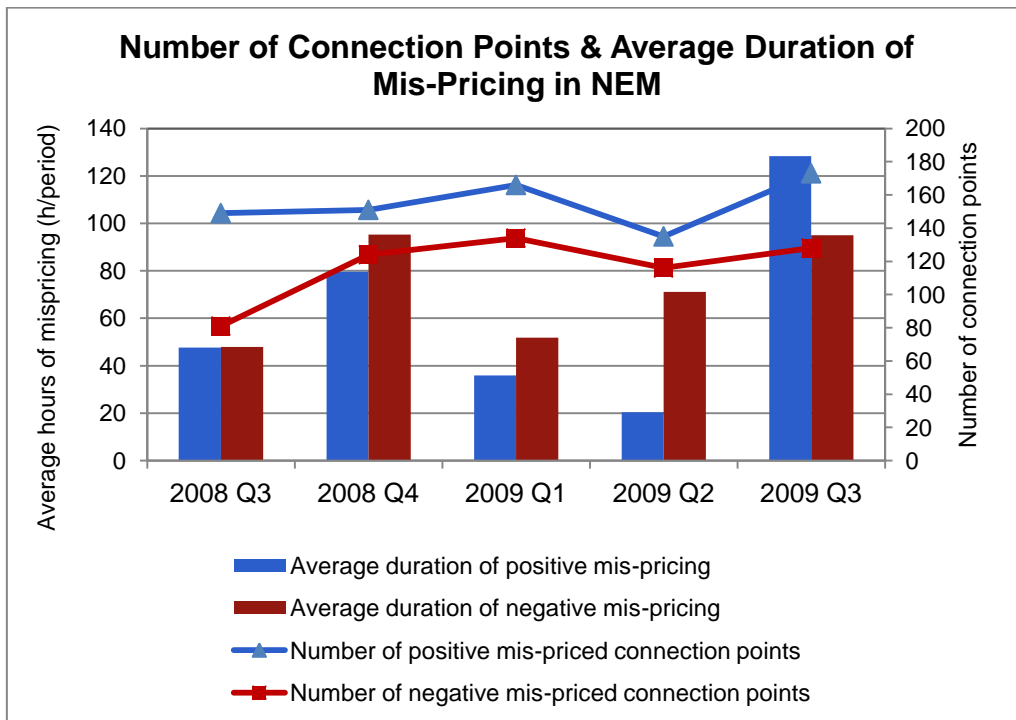

Figure 2. 5 NEM: Number of mis-priced connection points and average duration of mis-pricing - Positive and Negative Mis-Pricing

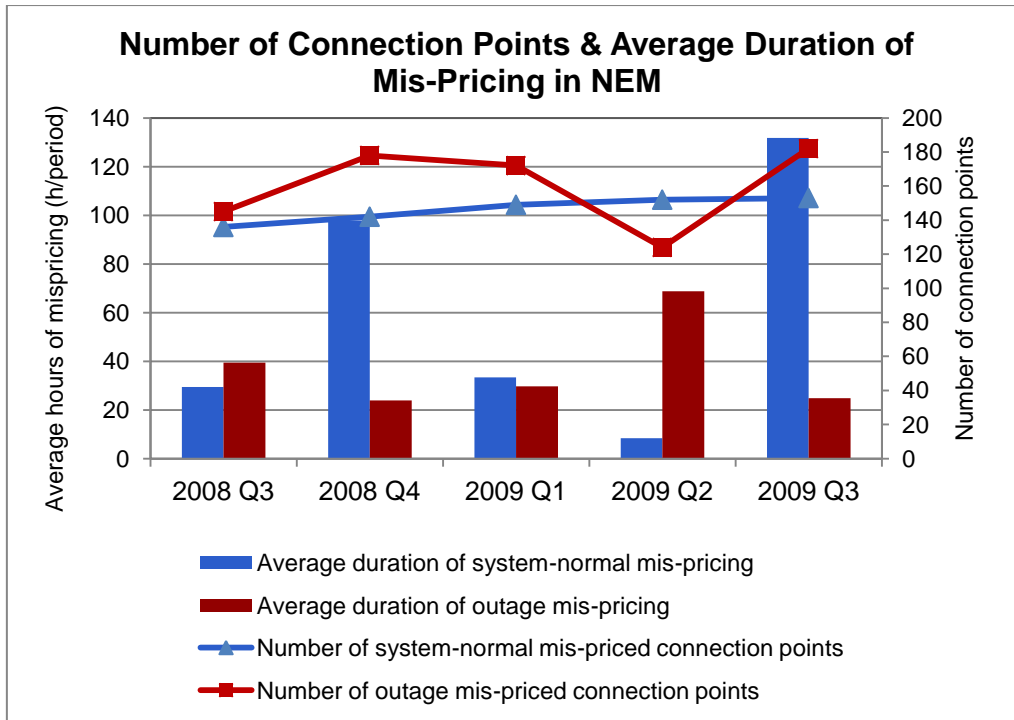

Figure 2. 6 NEM: Number of connection points and average duration of mis-pricing
- System Normal and Outage

5.3.2 Region Specific – Quarterly Comparison

This section presents mis-pricing information across all affected connection points at regional level. The corresponding section in the accompanying publication “Mis-Pricing due to Network Congestion” is divided into five sub sections.

- Sub-section 3.1 provides information pertaining to Queensland
- Sub-section 3.2 provides information pertaining to New South Wales
- Sub-section 3.3 provides information pertaining to Victoria
- Sub-section 3.4 provides information pertaining to South Australia and
- Sub-section 3.5 provides information pertaining to Tasmania

The results provide information on the number of mis-priced connection points, the average amount (\$/MWh) of mis-pricing and the average duration of mis-pricing in a given region (in this case Queensland) across five consecutive quarters, as listed below:

- The number of mis-priced connection points and the average amount of mis-pricing (Figure 3.1.1).
- The number of mis-priced connection points and the average positive mis-pricing amounts and negative mis-pricing amounts shown (Figure 3.1.2).
- The number of mis-priced connection points and the average mis-pricing amount, with the distinction made between mis-pricing incurred during system normal conditions and during outage conditions (Figure 3.1.3).
- The number of mis-priced connection points and the average duration mis-pricing occurred for (Figure 3.1.4).
- The number of mis-priced connection points and the average duration mis-pricing occurred for, with the distinction made between positive mis-pricing and negative mis-pricing (Figure 3.1.5).
- The number of mis-priced connection points and the average duration mis-pricing occurred for, with the distinction made between mis-pricing incurred during system normal conditions and during outage conditions (Figure 3.1.6)

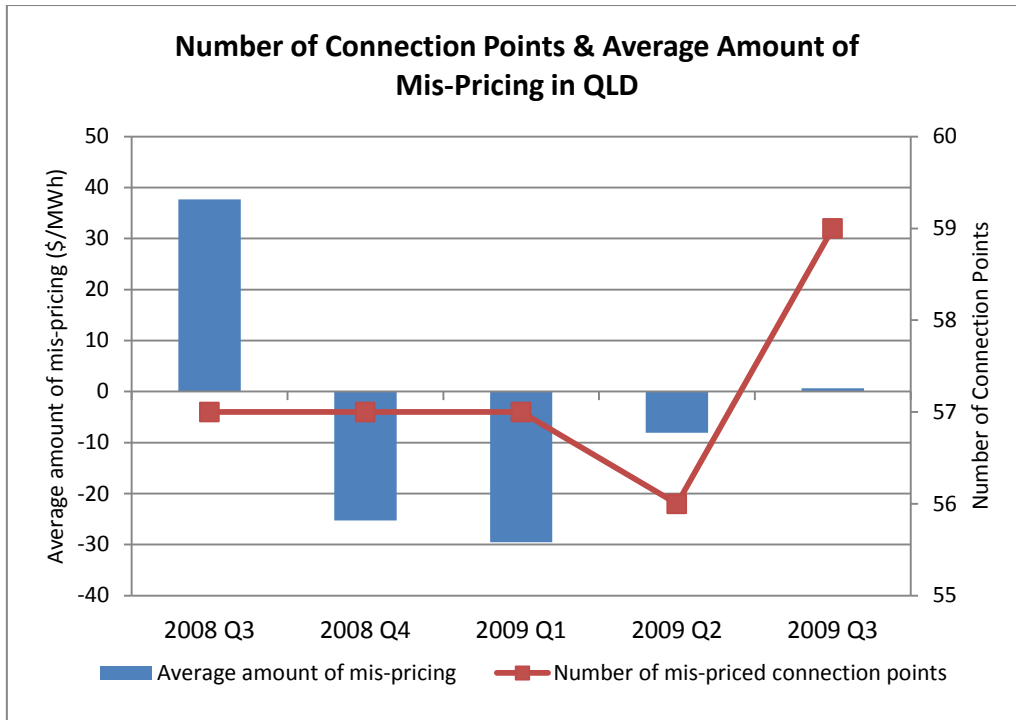

Figure 3.1. 1 QLD: Number of connection points and average amount of mis-pricing

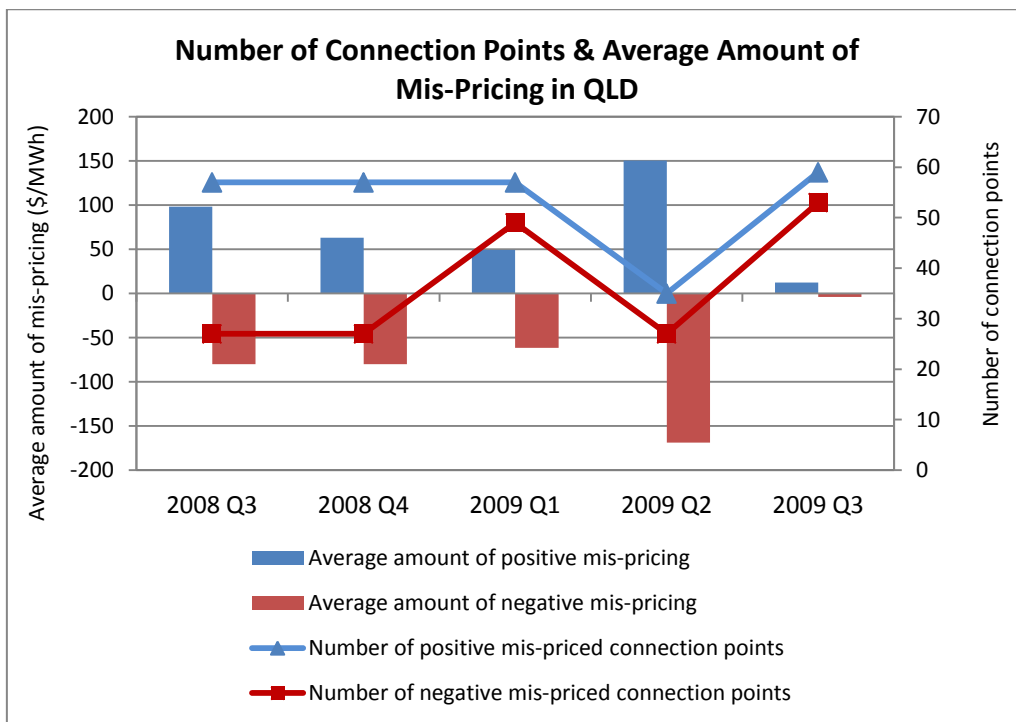

Figure 3.1. 2 QLD: Number of connection points and average amount of mis-pricing - Positive and Negative Mis-Pricing

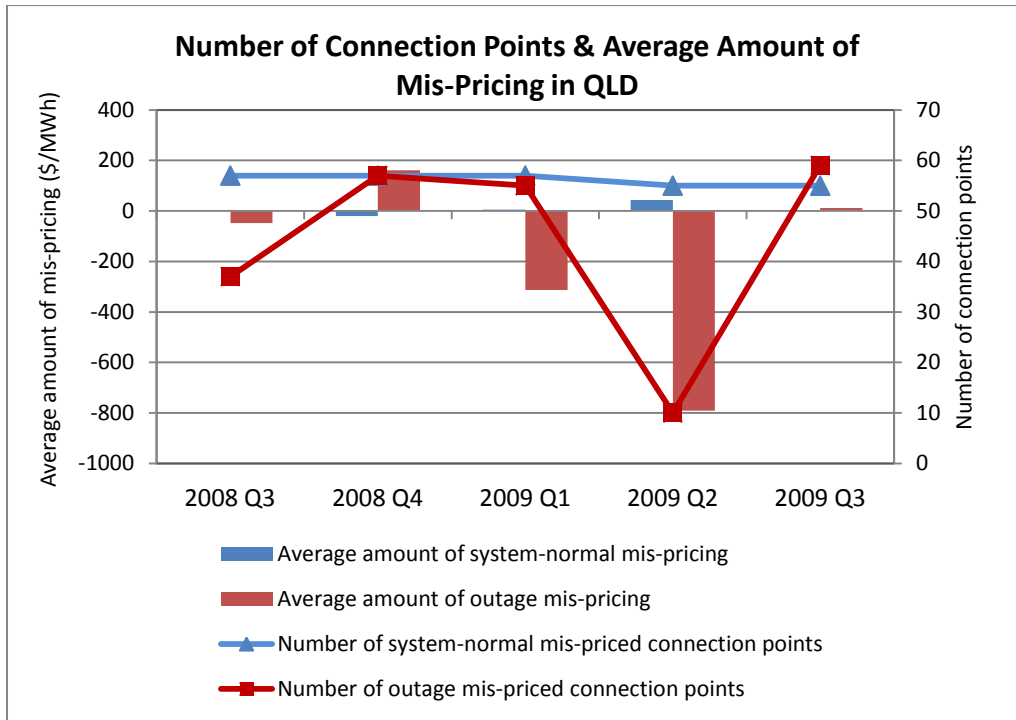

Figure 3.1. 3 QLD: Number of connection points and average amount of mis-pricing - System Normal and Outage

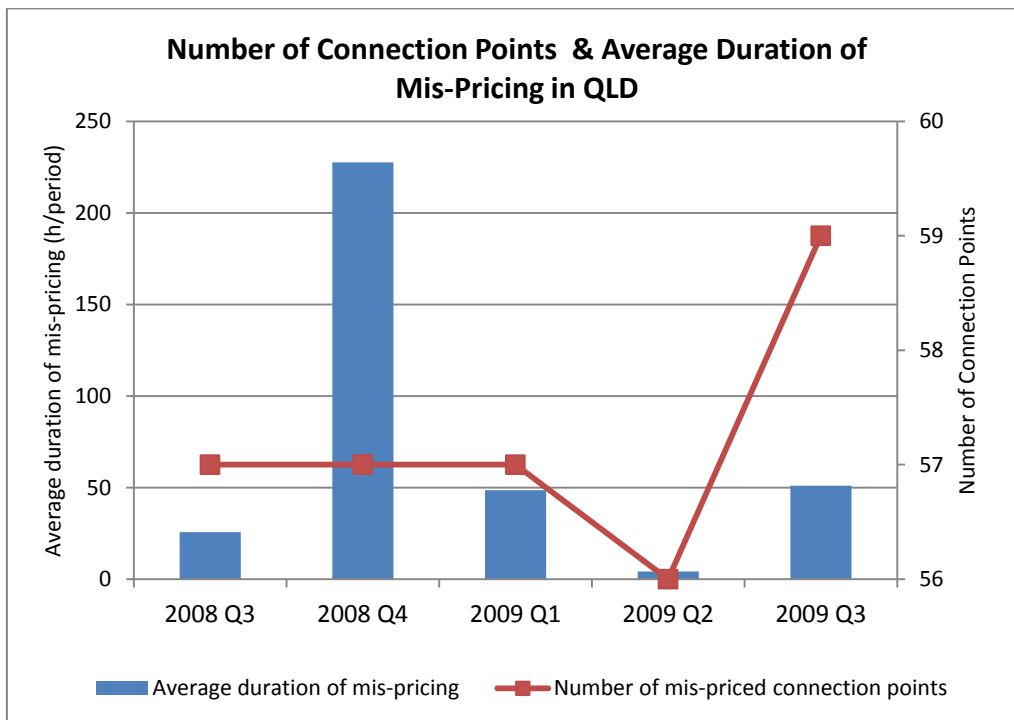

Figure 3.1. 4 QLD: Number of connection points and average duration of mis-pricing

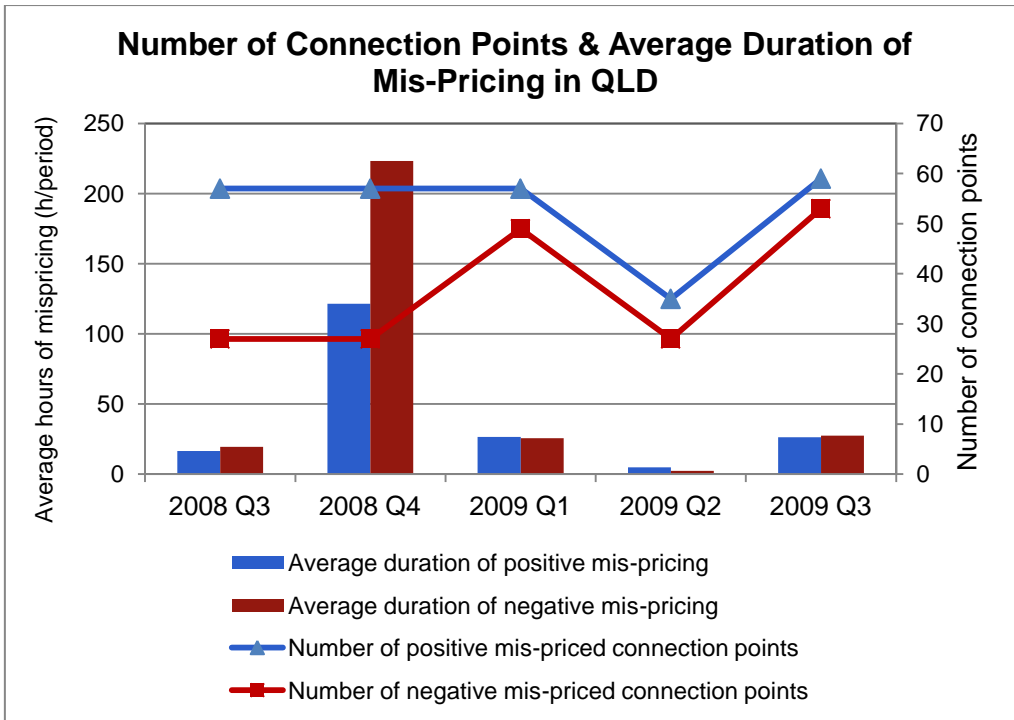

Figure 3.1. 5 QLD: Number of connection points and average duration of mis-pricing - Positive and Negative Mis-Pricing

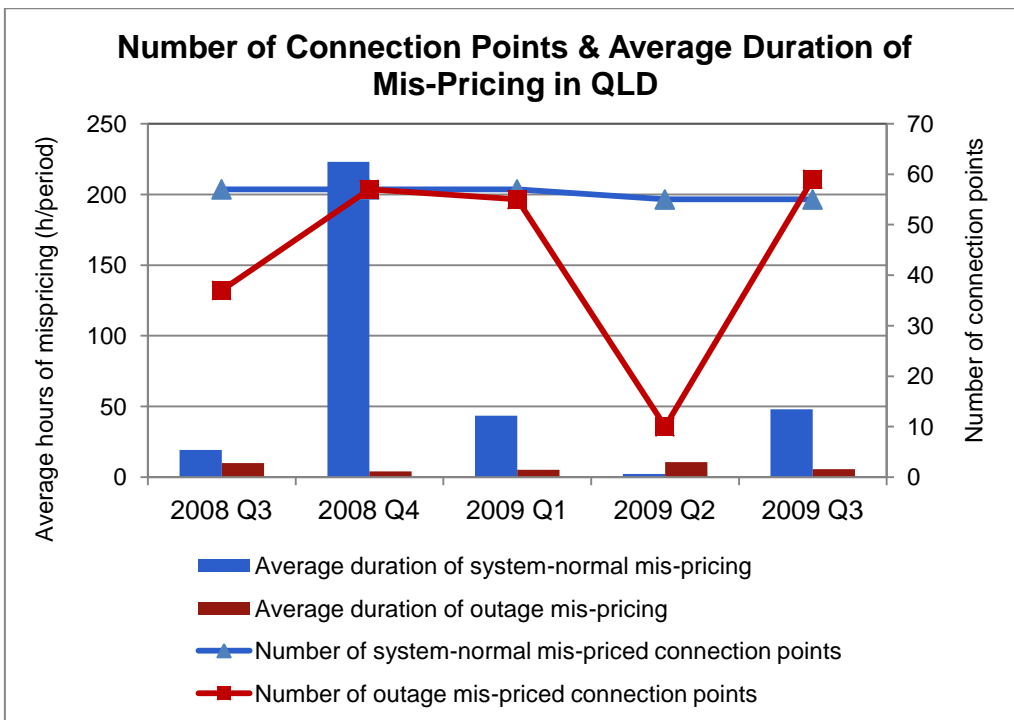

Figure 3.1. 6 QLD: Number of connection points and average duration of mis-pricing - System Normal and Outage

5.3.3 Regional per Connection Point

The final section provides mis-pricing information for all the regions separately. Information is provided at connection point level for the latest quarter only. Information is only displayed for connection points where the total hours of mis-pricing exceed a specified threshold value during a 3 month period. These threshold numbers are displayed on the graphs. The corresponding section in the accompanying publication “Mis-Pricing due to Network Congestion” is divided into five sub sections:

- Sub-section 4.1 provides information pertaining to Queensland
- Sub-section 4.2 provides information pertaining to New South Wales
- Sub-section 4.3 provides information pertaining to Victoria
- Sub-section 4.4 provides information pertaining to South Australia and
- Sub-section 4.5 provides information pertaining to Tasmania

These graphs will highlight the connection points most affected by mis-pricing, in terms of both dollar value per MWh and duration in hours. Information for New South Wales is used in this section for illustrative purposes.

- The average amount of mis-pricing at the affected connection points (Figure 4.2.1).
- The average amount a connection point was mis-priced, with positive mis-pricing amounts and negative mis-pricing amounts shown (Figure 4.2.2).
- The average amount a connection point was mis-priced, with the distinction made between the mis-pricing during system normal conditions and outage conditions (Figure 4.2.3).
- The number of hours a connection point was mis-priced (Figure 4.2.4).
- The number of hours a connection point was mis-priced for, with the distinction made between hours of positive mis-pricing and hours of negative mis-pricing (Figure 4.2.5).
- The number of hours a connection point was mis-priced for, with the distinction made between system normal conditions and during outage conditions (Figure 4.2.6).

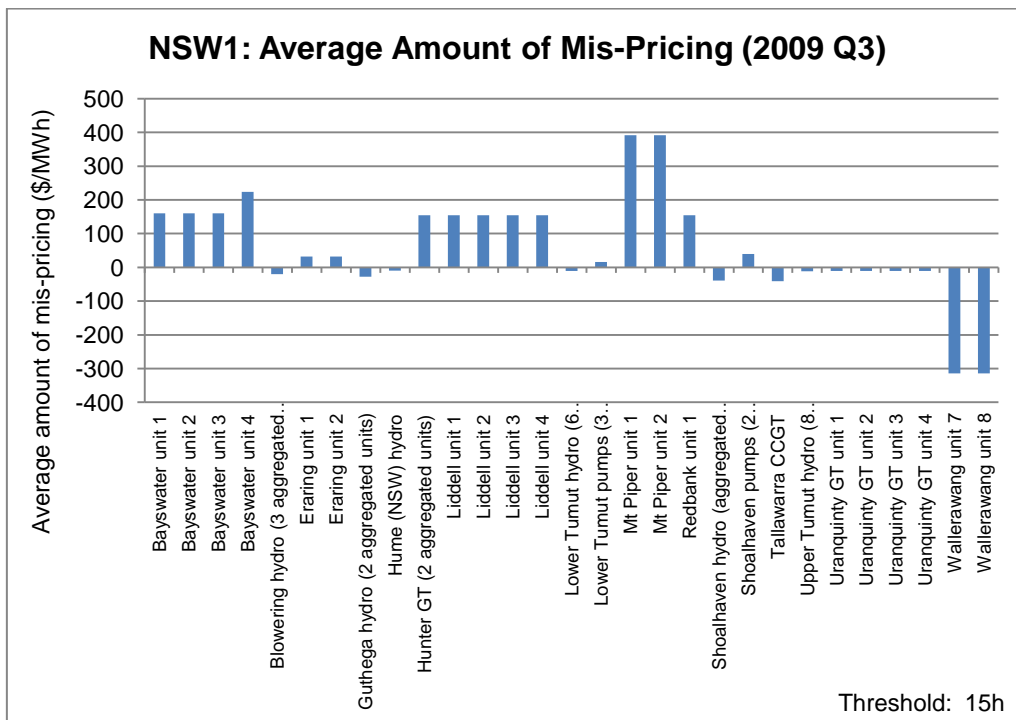

Figure 4.2. 1 NSW: Average amount of mis-pricing per connection point

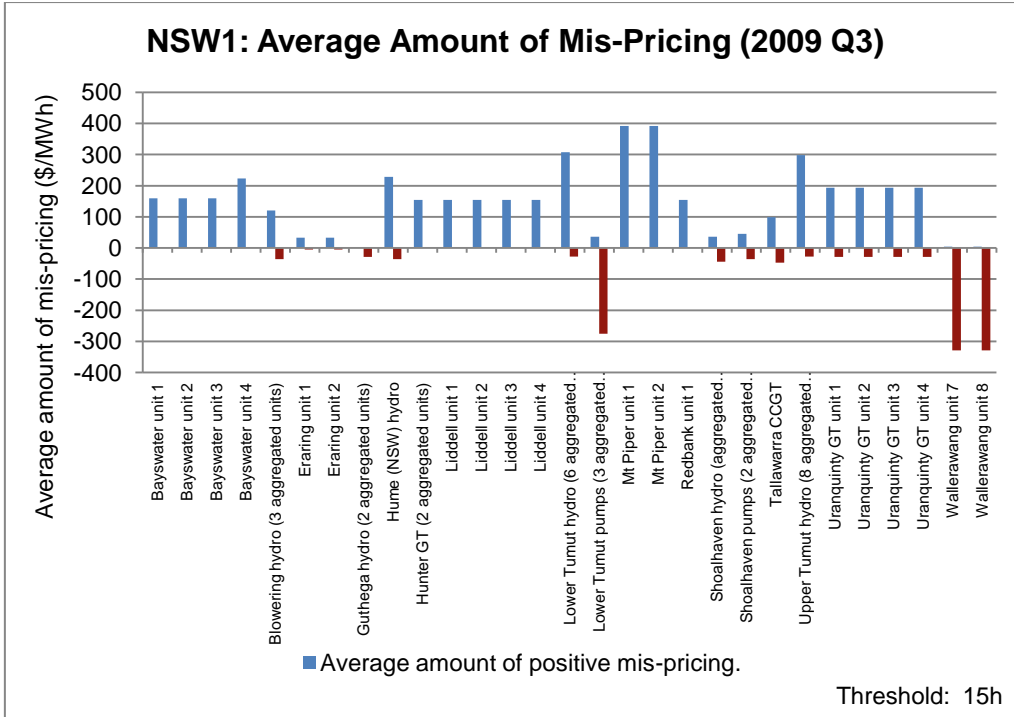

Figure 4.2. 2 NSW: Average amount of mis-pricing per connection point - Positive and Negative Mis-pricing

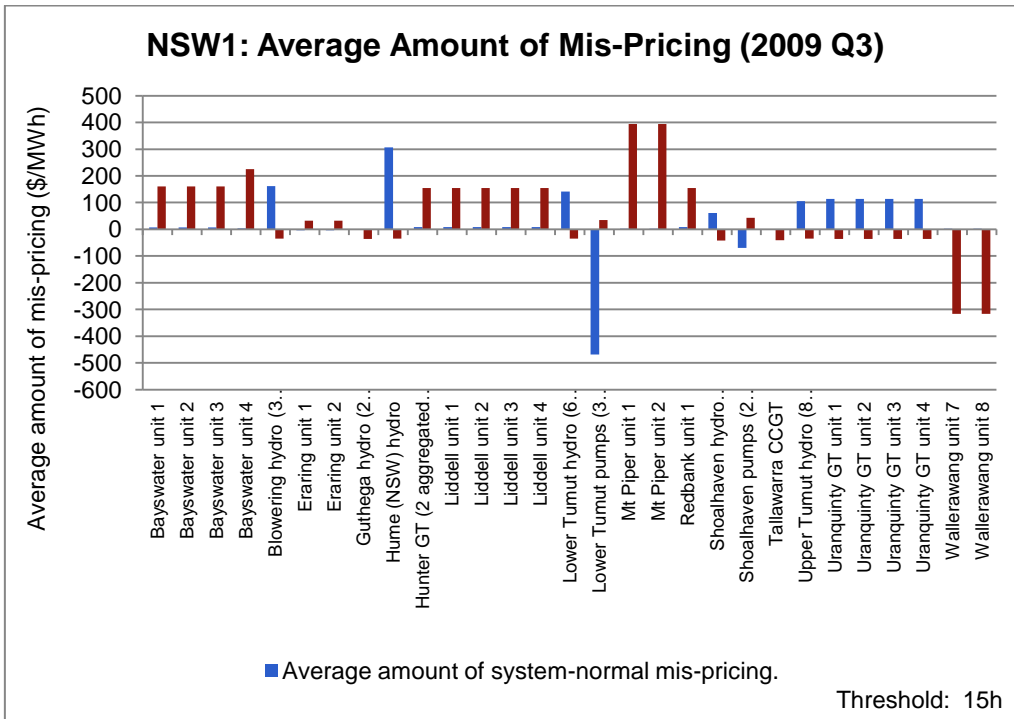

Figure 4.2. 3 NSW: Average amount of mis-pricing per connection point - System Normal and Outage

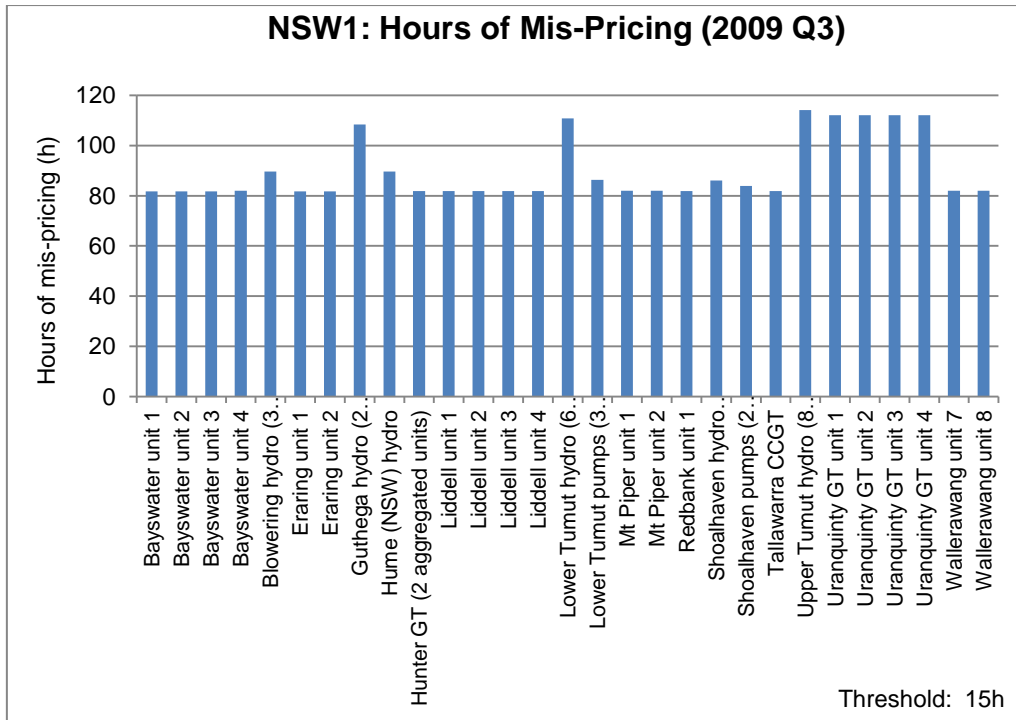

Figure 4.2. 4 NSW: Average duration of mis-pricing per connection point

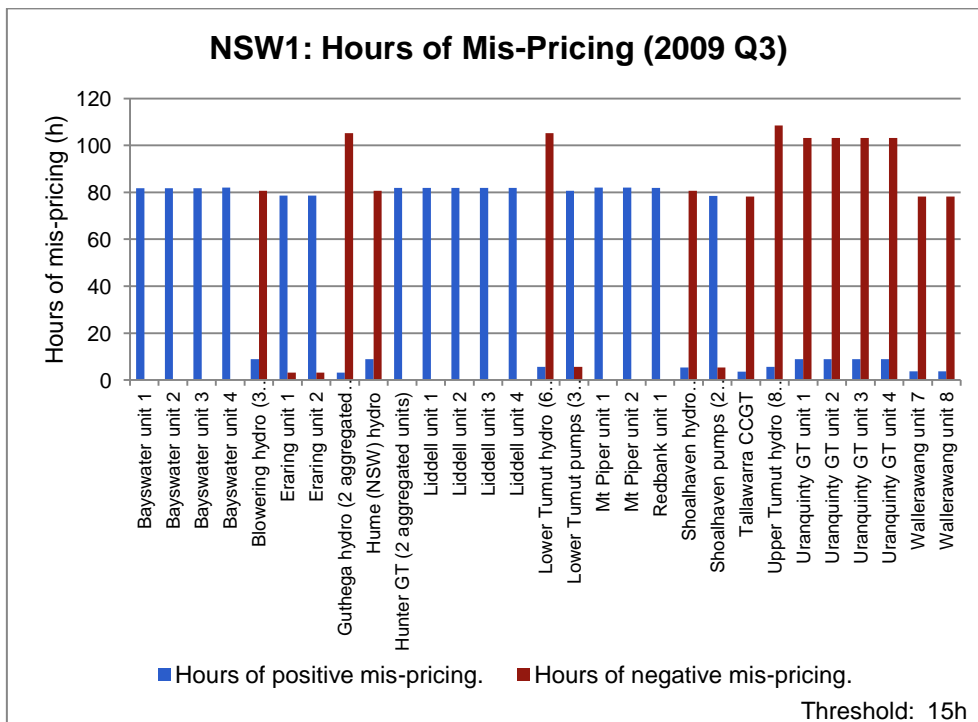

Figure 4.2. 5 NSW: Average duration of mis-pricing per connection point - Positive and Negative mis-pricing

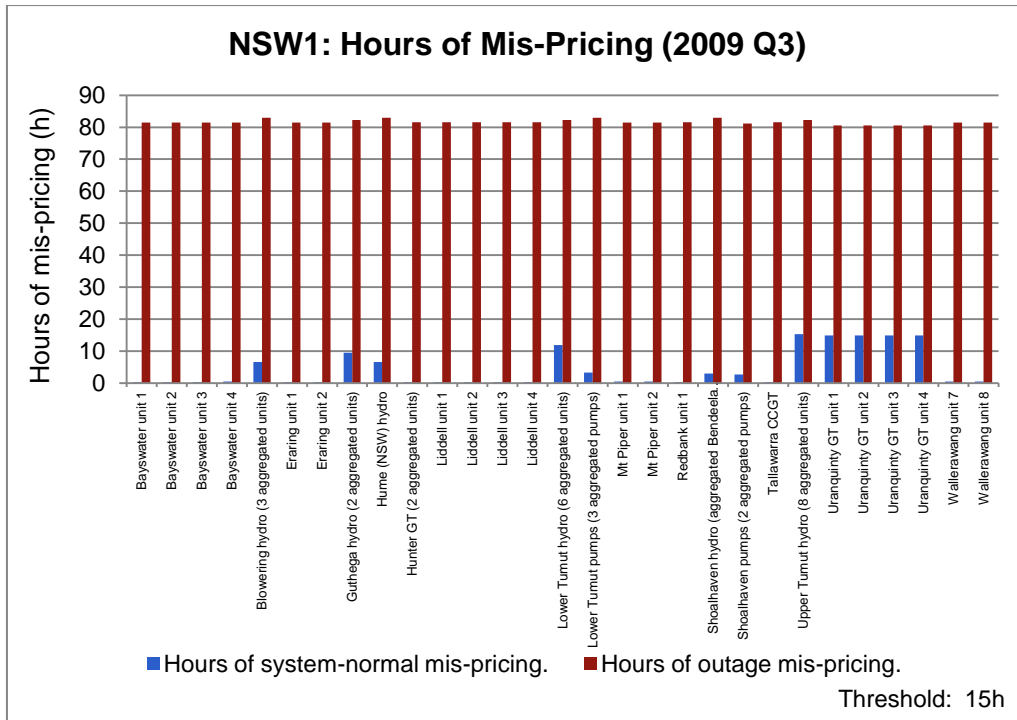

Figure 4.2. 6 NSW: Average duration of mis-pricing per connection point - System Normal and Outage

6 References

1. Biggar, Darryl. "Congestion Management Issues: How Significant is the Mis-pricing Impact of Intra-Regional Congestion in the NEM?" October, 2006.
2. Congestion Management Review: Final Report
<http://www.aemc.gov.au/electricity.php?r=20080616.170500>.
3. Congestion Management Review: Draft Rules

<http://www.aemc.gov.au/pdfs/reviews/Congestion%20Management%20Review/Final%20Report/aemc/009Final%20Report%20-%20Appendix%20G%20-%20Draft%20Rules.PDF>.

7 Appendix A

The following scenario will show that the mis-pricing amount at a connection point is positive when a binding constraint causes the generator at the connection point to be constrained-off.

Consider the following scenario, with bus B the regional reference node (RRN):

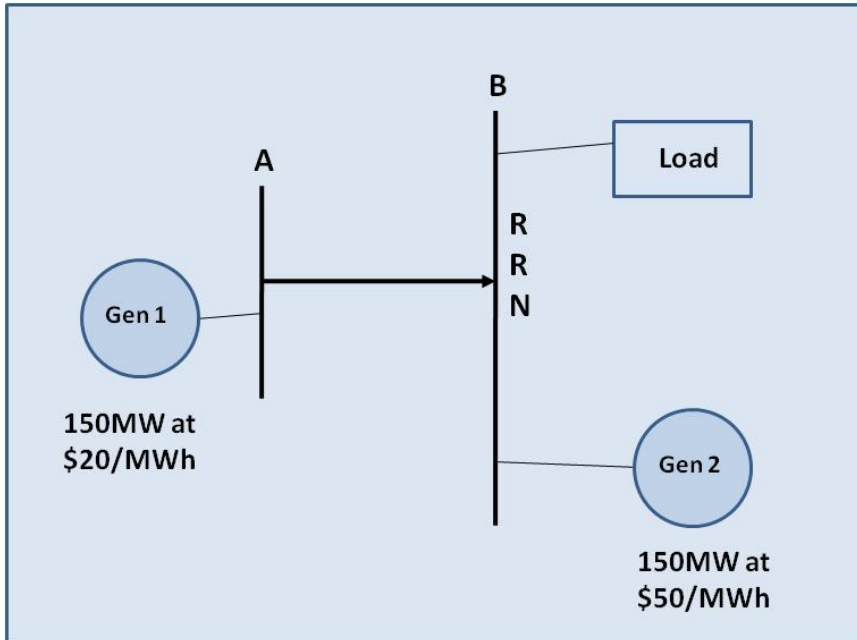

Gen 1 is offering its generation at \$20/MWh, and Gen 2 is offering its generation at \$50/MWh. Assume the flow limit on line $AB = 80 \text{ MW}$, and the load at the RRN is 100 MW . Ignore losses.

The linear programming (LP) problem can be written as:

$$OF = \text{minimise } (20G_1 + 50G_2) \quad (1)$$

Subject to:

$$G_1 \leq 80 \text{ MW} \quad (= RHS) \quad (2)$$

$$G_1 + G_2 = 100 \text{ MW},$$

where $G_i =$ generation at Gen i .

Solution:

$G_1 = 80\text{MW}$, $G_2 = 20\text{MW}$ and with the total cost given by the objective function $OF = \$2600$.

The RRP = \$50/MWh, since an additional 1 MW of load at the regional reference node can only be met by Gen 2 at \$50/MWh.

Note that the constraint equation $G_1 = 80 \text{ MW}$ is binding.

This marginal value of the binding constraint is calculated as the change in the value of the objective function when relaxing the right hand side of the binding constraint by 1 MW. Changing the RHS of (2) to 81 MW means that generator G_1 will now be cleared for 81 MW, while G_2 will be dispatched to 19 MW.

Therefore

$$\Delta RHS = +1 \text{ MW},$$

$$\Delta G_1 = +1 \text{ MW and}$$

$$\Delta G_2 = -1 \text{ MW.}$$

The change in the objective function (1) is then

$$\frac{\Delta OF}{\Delta RHS} = \frac{+20-50}{+1} = -\$30 = MV < 0.$$

In section 3 it was shown that the mis-pricing amount is calculated as

$$MPA_A = -1 \times MV = \$30, \tag{3}$$

where

MV = the marginal value of the binding constraint.

It follows from (3) that $MPA_A > 0$.

The local price can also be calculated using the equation (2b) in section 4:

$$LocalPrice_i = RRP - MPA_i = \$50 - \$30 = \$20 .$$

The mis-pricing amount at a connection point is therefore *positive* when a binding constraint causes the generator at the connection point to be *constrained-off*.

8 Appendix B

The following scenario will show that the mis-pricing amount at a connection point is negative when a binding constraint causes the generator at the connection point to be constrained-on.

Consider the following scenario, with bus B the regional reference node:

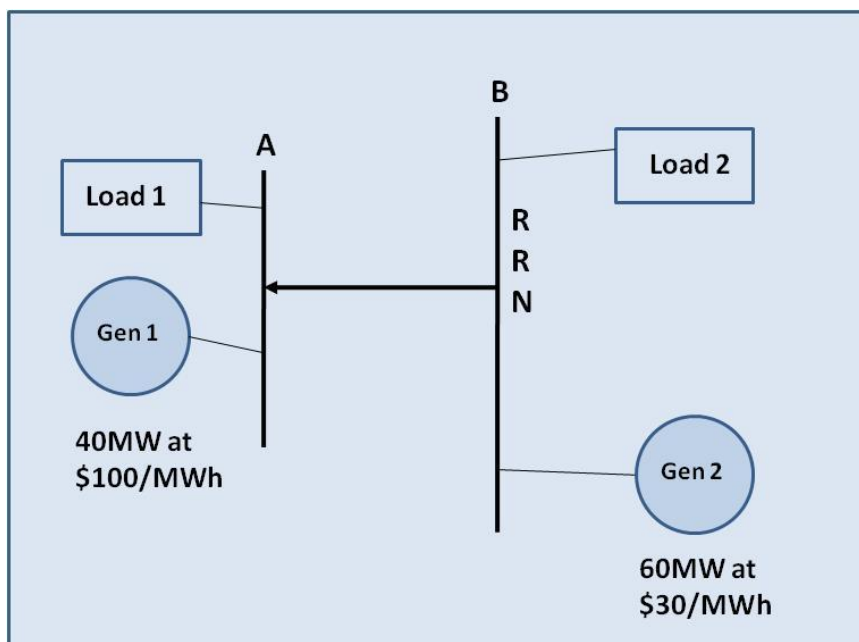

Gen 1 is offering its generation at \$100/MWh, and generator Gen 2 is offering its generation at \$30/MWh. The demand at bus B is given by Load 2 = 40 MW. Assume Load 1 = 30 MW and the flow limit on line AB = 10 MW.

The linear programming (LP) problem can be written as:

$$OF = \text{minimise } (100G_1 + 30G_2) \quad (4)$$

Subject to:

$$G_1 \geq \text{Load 1} - 10 \text{ MW}$$

i.e. $G_1 \geq 20 \text{ MW} \quad (5)$

and $G_1 + G_2 = 70 \text{ MW}.$

Solution:

$G_1 = 20 \text{ MW}$, $G_2 = 50 \text{ MW}$ and with the total cost given by the objective function

$$OF = \$2000 + \$1500 = \$3500.$$

The RRP = \$30/MWh since an additional MW of load at the regional reference node will be met by Gen 2 at \$30/MWh.

Changing the RHS of (5) to 21 MW means that Gen 1 will now be cleared for 21 MW, while G_2 will be dispatched to 49 MW.

Therefore

$$\Delta RHS = +1 \text{ MW},$$

$$\Delta G_1 = +1 \text{ MW and}$$

$$\Delta G_2 = -1 \text{ MW}.$$

The change in the objective function (4) is then

$$\frac{\Delta OF}{\Delta RHS} = \frac{-30+100}{+1} = +\$70 = MV > 0.$$

It follows that $MPA_A = -1 \times MV = -\$70 < 0$.

The local price can also be calculated using the equation (2b) in section 4:

$$LocalPrice_i = RRP - MPA_i = \$30 - (-\$70) = \$100.$$

The mis-pricing amount at a connection point is therefore *negative* when a binding constraint causes the generator at the connection point to be *constrained-on*.