

Power System Model Guidelines

Prepared by: AEMO Operations

Version: 2.0

Effective date: 14 July 2023

Status: FINAL

Approved for distribution and use by:

Approved by: Michael Gatt

Title: Executive General Manager - Operations

Date: 13 July 2023

aemo.com.au

New South Wales | Queensland | South Australia | Victoria | Australian Capital Territory | Tasmania | Western Australia

Australian Energy Market Operator Ltd ABN 94 072 010 327

Contents

| | |
|---|------------------------|
| Current version release details | 4 |
| 1. Introduction | 5 |
| 1.1. Purpose and scope | 5 |
| 1.2. Definitions and interpretation | 5 |
| 1.3. Related documents | 8 |
| 1.4. Context | 8 |
| 2. Provision of models and other information | 10 |
| 2.1. Generators and Integrated Resource Providers | 10 |
| 2.2. Network Service Providers | 1244 |
| 2.3. Network Users | 12 |
| 2.4. Market Network Service Providers | 1342 |
| 2.5. NSCAS tenderers | 13 |
| 2.6. Prospective SRAS Providers | 1443 |
| 3. Models and data requirements | 1413 |
| 3.1. Generators, Integrated Resource Providers, NSPs, and MNSPs | 14 |
| 3.2. Network Users (for loads) | 1544 |
| 3.3. NSCAS tenderers and SRAS Providers | 1645 |
| 3.4. Exemptions | 16 |
| 4. Model adequacy | 1716 |
| 4.1. Load flow model requirements | 1847 |
| 4.2. Fault level model requirements | 1948 |
| 4.3. RMS and EMT stability model requirements | 1948 |
| 4.4. Conventional EMT model requirements | 3234 |
| 4.5. Small-signal model requirements | 34 |
| 4.6. Power quality model requirements | 3534 |
| 4.7. Model aggregation | 3837 |
| 4.8. Model and plant updates | 4140 |
| 5. Model documentation | 4443 |
| 5.1. Releasable user guide | 4443 |
| 5.2. RMS and EMT model documentation | 4544 |
| 5.3. Small-signal stability model documentation | 4746 |
| 5.4. Harmonic model documentation | 4746 |
| 6. Model accuracy requirements | 4846 |
| 6.1. Accuracy locations | 4847 |
| 6.2. Model performance measures | 4847 |
| 6.3. Model validation and confirmation | 5250 |
| 6.4. Non-conformance with model accuracy requirements | 5755 |
| 7. Confidentiality of information and models provided | 5756 |
| 7.1. Storage and use by AEMO | 5756 |
| 7.2. Intellectual property | 5756 |
| 7.3. EMT model black-boxing, compilation or encryption | 5756 |

| | |
|--|--------------------|
| 7.4. Provision of information and models to third parties | <u>5856</u> |
| 8. Alternative process | <u>6059</u> |
| 8.1. Generally | <u>6159</u> |
| 8.2. Examples of requests | <u>6159</u> |
| 8.3. Consideration of request | <u>6159</u> |
| 8.4. Determination | <u>6260</u> |
| Appendix A. Application for exemption from the requirement to provide model and other information | <u>6361</u> |
| Appendix B. Application to provide alternative model or information | <u>6462</u> |
| Appendix C. Modelling component requirements | <u>6563</u> |
| C.1 Definitions and notes | <u>6563</u> |
| C.2 Wind generation | <u>6765</u> |
| C.3 Photovoltaic generation | <u>6866</u> |
| C.4 Converter-based energy storage systems | <u>7068</u> |
| C.5 Inverter-based load | <u>7270</u> |
| C.6 High voltage DC link | <u>7472</u> |
| C.7 Synchronous machines and generators | <u>7573</u> |
| C.8 Converter-based reactive support systems | <u>7674</u> |
| Appendix D. Quantities to be assessed for transient and voltage analysis | <u>7876</u> |
| Appendix E. Transient window definitions | <u>8179</u> |
| E.1 Transient window for an uncontrolled change | <u>8179</u> |
| E.2 Transient window for a controlled change | <u>8280</u> |
| Version release history | <u>8381</u> |

Tables

| | |
|---|-------------|
| Table 1 Defined terms | 5 |
| Table 2 Related documents | 8 |
| Table 3 Grounds on which exemption may be granted | 16 |
| Table 4 Load flow model inclusions | <u>1847</u> |
| Table 5 Required model output quantities | <u>2827</u> |
| Table 6 Simulation tools required for R2 model validation (<i>generating systems and integrated resource systems</i>) | <u>5453</u> |
| Table 7 Models to be provided by AEMO | <u>5957</u> |

Figures

| | |
|---|-------------|
| Figure 1 Interrelationship of System Security Market Framework components | 9 |
| Figure 2 Aggregated and black-boxed EMT model high level representation | <u>4140</u> |

Current version release details

| Version | Effective date | Summary of changes |
|---------|----------------|--|
| 2.0 | 14 July 2023 | Final guidelines following 2023 consultation |

Note: There is a full version history at the end of this document.

1. Introduction

1.1. Purpose and scope

These are the Power System Model Guidelines (**Guidelines**) made under clause S5.5.7(a)(3) of the National Electricity Rules (**NER**). They specify AEMO's requirements concerning *the* information and models that *Connection Applicants, Registered Participants, Generators, NSPs, Network Users, MNSPs, prospective NSCAS tenderers and prospective SRAS Providers (collectively, Applicants)* must provide to AEMO and *Network Service Providers (NSPs)* in ~~the specified~~ circumstances specified in the NER.

AEMO requires this information and models to develop mathematical models for plant, including the impact of their *control systems* and protection systems on *power system security*.

These Guidelines have effect only for the purposes set out in the NER. The NER and the *National Electricity Law* prevail over these Guidelines to the extent of any inconsistency.

1.2. Definitions and interpretation

1.2.1. Glossary

The words, phrases and abbreviations in Table 1 have the meanings set out opposite them when used in these Guidelines.

Terms defined in the *National Electricity Law* and the NER have the same meanings in these Guidelines unless otherwise specified in this Section 1.2.1.

Terms defined in the NER (including a future version of the NER) are intended to be identified in these Guidelines by italicising them, but failure to italicise a defined term does not affect its meaning.

Terms defined in a version of the NER that takes effect after the date of publication of these Guidelines have the meaning given in the relevant amending rule and in any applicable transitional provisions in the NER prior to their commencement.

Table 1 Defined terms

| Term | Definition |
|-----------------------------|--|
| Applicants | <i>Connection Applicants, Registered Participants, Network Users, NSCAS tenderers and prospective SRAS Providers. Generators, NSPs, Network Users, MNSPs, prospective NSCAS tenderers and prospective SRAS Providers</i> to whom these Guidelines apply <u>in the circumstances specified in the NER</u> . |
| AGC | automatic generation control |
| AVR | <i>a</i> automatic voltage regulator |
| BFP | <i>B</i> oiler feed-pump |
| <u>Composite load model</u> | <u>A mathematical representation of a load based on separation into explicit components with generic parameterised descriptions. An example is the CMLDxx family of models in PSS@E</u> |
| CT | Current T ransformer |
| Data Sheets | <i>Power System Design Data Sheets</i> and <i>Power System Setting Data Sheets</i> |
| DC | <i>D</i> irect current |

| Term | Definition |
|-------------|---|
| Disturbance | Any, or a combination of the following: <ul style="list-style-type: none"> • A balanced or unbalanced fault remote from a <i>connection point</i>. • A balanced or unbalanced fault at, or close to, a <i>connection point</i>. • A transmission line, distribution line or other plant switching or tripping; • A trip, with or without a fault, of one or more <i>generating production -units</i> (from the same, or another <i>generating system</i> <u>or <i>integrated resource system</i></u>) or <i>Customer loads</i>. • A short or long <i>voltage</i> disturbance (e.g. as could occur when a part of the <i>network</i> is close to <i>voltage</i> collapse). • A <i>frequency</i> disturbance (e.g. as could occur when a part of the <i>network</i> is islanded). • Rapid, large changes in the energy source available to the <i>plant</i> (e.g. as could occur when cloud cover affects PV energy availability), resulting in substantial <i>active power</i> ramping of the <i>generating system</i> <u>or <i>integrated resource system</i></u>. |
| DLL | <u>d</u> ynamically linked library |
| <u>DOL</u> | <u>D</u> irect on line |
| DSA | <u>D</u> ynamic security assessment |
| EMT | <u>E</u> lectromagnetic transient |
| FACTS | <u>f</u> l <u>F</u> lexible AC transmission systems |
| FCAS | <u>f</u> requency control ancillary services <u>F</u> requency control ancillary services (<u>m</u> arket ancillary services) |
| FDF | Forced <u>D</u> raft <u>f</u> an |
| FRT | <u>F</u> ault ride-through |
| HIL | <u>h</u> ardware-in- <u>t</u> he-loop |
| HV | <u>H</u> igh voltage |
| HVDC | <u>H</u> igh voltage direct current |
| HVRT | <u>H</u> igh voltage ride-through |
| <u>Hz</u> | <u>H</u> ertz |
| <u>IBL</u> | <u>i</u> nverter-based load |
| IDF | Induced <u>d</u> raft <u>F</u> an |
| <u>IEEE</u> | <u>I</u> nstitute of Electrical and Electronics Engineers |
| IGBT | <u>i</u> nsulated gate bipolar transistor |
| kHz | <u>K</u> ilohertz |
| LCC | Line- <u>c</u> ommutated <u>c</u> onverter |
| LV | <u>l</u> ow voltage |
| LVRT | <u>L</u> ow voltage ride-through |
| MBASE | Machine <u>b</u> ase <u>m</u> egavolt <u>a</u> mpere |
| MNSP | <i>Market Network Service Provider</i> |
| ms | <u>M</u> illisecond |
| MVA | <u>M</u> egavolt ampere |
| MV | <u>m</u> edium voltage |
| <u>MW</u> | <u>M</u> egawatt |
| NER | National Electricity Rules |
| <u>NREL</u> | <u>N</u> ational Renewable Energy Laboratory |
| NSP | <i>Network Service Provider</i> |
| <u>OEM</u> | <u>O</u> riginal equipment manufacturer |
| OLTC | <u>O</u> en load tap changer |
| OPDMS | Operations and Planning Data Management System |
| PCC | <u>P</u> oint of common coupling |
| PI | <u>P</u> roportional integral |
| PID | <u>P</u> roportional integral derivative |
| PLC | Programmable <u>L</u> ogic <u>c</u> ontroller |

| Term | Definition |
|------------------------------|--|
| PLL | <u>P</u> hase locked loop |
| POD | <u>P</u> ower oscillation damper |
| Post-Contingent Steady State | The condition of a <i>power system</i> immediately after a <u>disturbance</u> <u>Disturbance</u> , when <i>power system</i> electrical quantities have obtained steady values following the action of fast-acting <i>plant</i> and <i>network</i> controls, but other slower-acting <i>control systems</i> may not yet have operated. |
| PPC | <u>p</u> ower plant controller (also known as 'power park controller') |
| PSCAD™/EMTDC™ | Power Systems Computer Aided Design / Electromagnetic Transient with Direct Current, <u>software developed by Manitoba Hydro International</u> . |
| PSS | Power <u>s</u> ystem <u>s</u> tabiliser |
| PSS@E | Power System Simulator for Engineering, <u>software developed by PTI-Siemens PTL</u> . |
| PWM | <u>P</u> ulse width modulation |
| Quasi-Steady state | Physically dynamic phenomena that can be represented in simulation using static analysis. |
| R2 | Registered data after connection, as derived from on-system testing and designated as 'R2' in the Data Sheets and as described further in <u>clause-NER S5.5.2S5.5.6 of the NER</u> . |
| Reticulation Network | The collector system of a <i>generating system</i> <u>or integrated resource system</u> comprising many <u>production generating units</u> . Typically, the medium <i>voltage</i> radial <i>network</i> of feeders that collect the output of the individual <u>production generating units</u> , supplying the <i>plant</i> step-up transformer(s). |
| RMS | <u>R</u> oot mean square |
| RUG | <u>R</u> eleasable user guide |
| SCADA | Supervisory <u>c</u> ontrol and <u>d</u> ata <u>a</u> cquisition |
| SCR | <u>S</u> hort circuit ratio |
| SMIB | Single machine and infinite bus (simplified network model) |
| <u>SSAT</u> | <u>Small Signal Analysis Toolboæx, software developed by Powertech Labs</u> . |
| SSCI | <u>S</u> ub-synchronous control interaction |
| SSR | <u>S</u> ub-synchronous resonance |
| SSTI | <u>S</u> ub-synchronous torsional interaction |
| STATCOM | <u>S</u> tatic compensator |
| Steady State | The electrical conditions prevailing in any 50 Hz <i>power system</i> after decay of transients, under either normal or contingency operating conditions and in the absence of short circuits, where the RMS variables of the <i>power system</i> (such as <i>voltage</i> and <i>current</i>) are unchanging in time. |
| SVC | <u>S</u> tatic VAR compensator |
| TNSP | <i>Transmission Network Service Provider</i> |
| TOV | <u>T</u> emporary overvoltages |
| TTHL | <u>T</u> rip to house load |
| Type 3 | (Wind turbine) a doubly-fed induction generator type |
| Type 4 | (Wind turbine) a back-to-back converter type |
| UPS | <u>U</u> ninterruptible power supply |
| VT | Voltage <u>t</u> ransformer |
| <u>ZIP</u> | <u>Constant impedance (Z), current (I), and power (P) load</u> |

1.2.2. Interpretation

The following principles of interpretation apply to these Guidelines unless otherwise expressly indicated:

- (a) These Guidelines are subject to the principles of interpretation set out in Schedule 2 of the *National Electricity Law*.
- (b) The words “includes”, “including” or “such as” are not words of limitation, and when introducing an example, do not limit the meaning of the words to which the example relates to examples of a similar kind.

1.3. Related documents

Table 2 Related documents

| Title | Location |
|--|---|
| NSCAS Tender Guidelines | https://www.aemo.com.au/Electricity/National-Electricity-Market-NEM/Security-and-reliability/Ancillary-services/Network-support-and-control-ancillary-services-procedures-and-guidelines |
| Power System Design Data Sheets | https://aemo.com.au/-/media/Files/Electricity/NEM/Security_and_Reliability/System-Security-Market-Frameworks-Review/2018/Power_System_Design_and_Setting_Data_Sheets_PUBLISHED.xlsx |
| Power System Setting Data Sheets | https://aemo.com.au/-/media/Files/Electricity/NEM/Security_and_Reliability/System-Security-Market-Frameworks-Review/2018/Power_System_Design_and_Setting_Data_Sheets_PUBLISHED.xlsx |
| SRAS Guideline | https://www.aemo.com.au/Stakeholder-Consultation/Consultations/SRAS-Guidelines-2017 |
| System Strength Impact Assessment Guidelines | https://aemo.com.au/-/media/Files/Electricity/NEM/Security_and_Reliability/System-Security-Market-Frameworks-Review/2018/System_Strength_Impact_Assessment_Guidelines_PUBLISHED.pdf https://aemo.com.au/en/energy-systems/electricity/national-electricity-market-nem/participate-in-the-market/network-connections/system-strength-impact-assessment-guidelines |
| Remedial Action Scheme Guidelines | https://aemo.com.au/energy-systems/electricity/national-electricity-market-nem/system-operations/remedial-action-scheme-guidelines |

1.4. Context

These Guidelines and the Data Sheets are tools that enable AEMO and ~~relevant the~~ NSPs to obtain the information needed to accurately model the behaviour of plant connected to the power system on an ongoing basis to fulfil ~~implement~~ a number of obligations under the NER, including those relating especially those that relate to meeting AEMO's power system security responsibilities and the management of new or altered connections to the national grid.

Figure 1 shows the interrelationship between these Guidelines and other NER instruments and AEMO guidelines, operating procedures and activities. By no means a complete depiction, it highlights the criticality of compliance by affected *Registered Participants* with these Guidelines by showing how they relate to key obligations imposed on AEMO and NSPs in the context of *power system security*.

Figure 1 Interrelationship of System Security Market Framework components

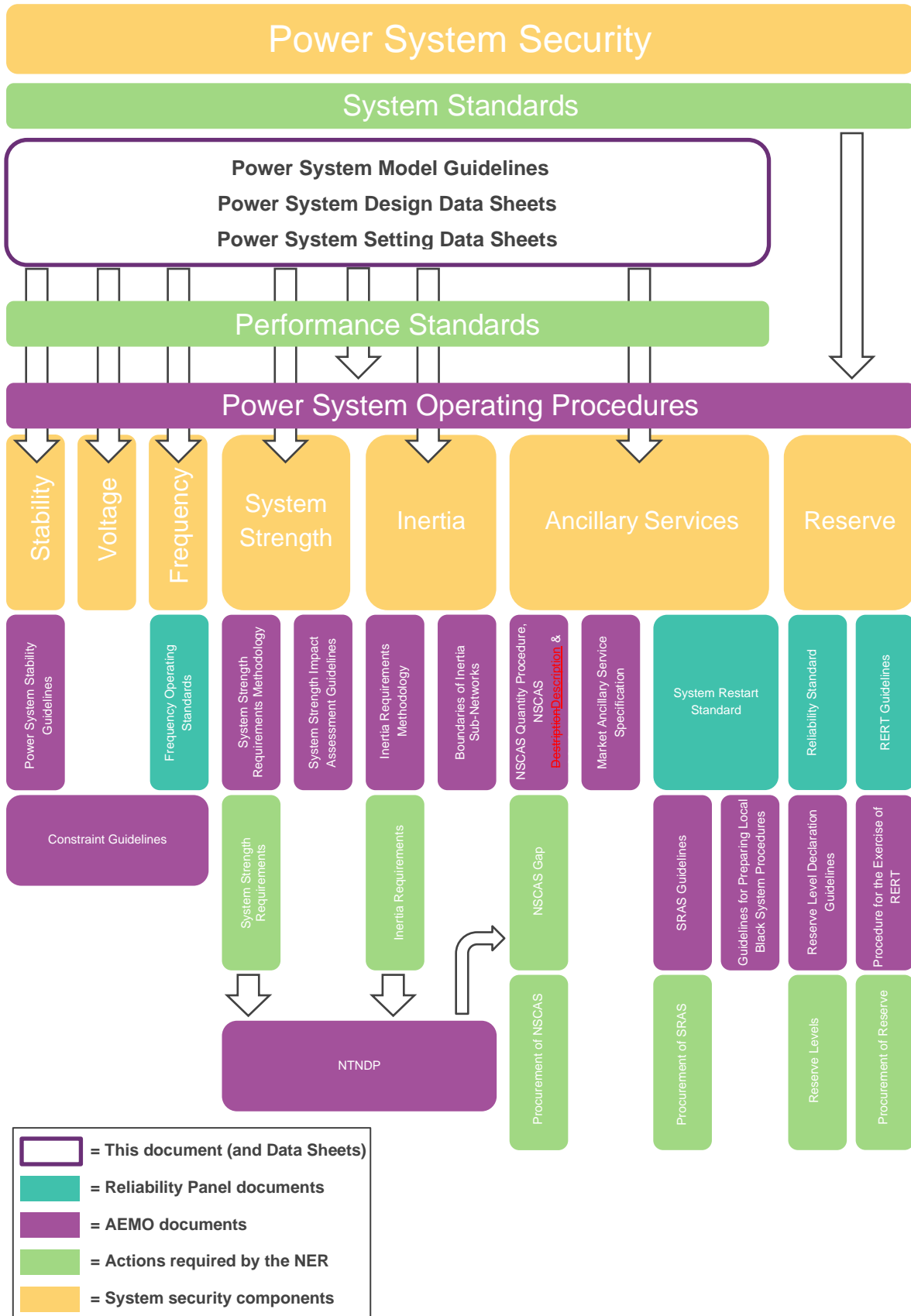

2. Provision of models and other information

Registered Participants and other persons required to provide models and other information to AEMO in respect of their *plant* must ensure that they are accurate and remain up to date as required by applicable NER provisions, including those listed in NER S5.5.7(a)(3).

If models or model parameters provided to AEMO for *connected plant* do not (or no longer) adequately represent the *plant*, this may have operational consequences for Registered Participants including:

- requirements to conduct testing under NER 5.7.6; or
- restricted operation of the *plant* under NER 5.7.3(f).

A Registered Participant who has previously provided adequate RMS models and associated information must comply with a request to provide up-to-date EMT models to AEMO and a relevant NSP, if the NSP requires them to conduct *system strength impact assessments*.

2.1. Generators and Integrated Resource Providers

Note: references in this section to Integrated Resource Providers, integrated resource systems and bidirectional units refer to the relevant provisions of the NER in effect on the *effective date* as defined in NER 11.145.1¹, or as subsequently amended.

The circumstances in which Generators and Integrated Resource Providers must provide models and other information to AEMO and relevant NSPs in respect of their *generating systems* under these Guidelines are specified in ~~clause NER S5.5.7(b1)(1)(i) of the NER~~ and are, in summary:

| Requirement | Timing |
|--|---|
| (a) Where there is, in AEMO's reasonable opinion, a risk that a <u>Generator's</u> or <u>Integrated Resource Provider's</u> <i>plant</i> will: <ol style="list-style-type: none"> (1) adversely affect <i>network capability</i>, <i>power system security</i>, quality or reliability of <i>supply</i>, or <i>inter-regional power transfer capability</i>; (2) adversely affect the use of a <i>network</i> by a <i>Network User</i>; or (3) have an <i>adverse system strength impact</i>². | Within 20 <i>business days</i> of AEMO's notice of the impact described in sub-paragraph (1), (2) or (3). |
| (b) Where, in AEMO's reasonable opinion, information of the type described in clause NER S5.2.4 of the NER is required to enable an NSP to conduct a <i>system strength impact assessment</i> ³ . | Within 15 <i>business days</i> of AEMO's request to provide the relevant information. |
| (c) Where the <u>Generator</u> or <u>Integrated Resource Provider</u> is proposing an alteration to a <i>generating system</i> or <u>integrated resource system</u> for which <i>performance standards</i> have been agreed and the alteration will: <ol style="list-style-type: none"> (1) affect the <i>generating system's</i> or <u>integrated resource system's</u> performance relative to any of the technical requirements in clauses NER S5.2.5, S5.2.6, S5.2.7 and S5.2.8 of the NER; or (2) in AEMO's reasonable opinion: <ol style="list-style-type: none"> (A) have an <i>adverse system strength impact</i>; or | Within 20 <i>business days</i> of AEMO's notice of the impact described in sub-paragraph (1) or (2). |

¹ As at the date of this publication, the date on which Schedules 1-6 of the *National Electricity Amendment (Integrating energy storage systems into the NEM) Rule 2021* come into effect.

² See ~~NER clause 5.2.5(d) of the NER~~. -See also footnote 2 for further information about *system strength impact assessments*.

³ See ~~NER clause 5.2.5(e) of the NER~~. -Where a *Generator* has previously provided an RMS model to AEMO, that model will be inadequate for carrying out a full *system strength impact assessment* and an EMT model will be required. -For further information about full *system strength impact assessments*, see the ~~*system strength impact assessment guidelines*~~-System Strength Assessment Guidelines.

| Requirement | Timing |
|---|---|
| (B) adversely affect <i>network capability</i> , quality or reliability of supply, <i>inter-regional power transfer capability</i> or the use of a <i>network</i> by another <i>Network User</i> ⁴ . | |
| (d) When negotiating a <i>connection agreement</i> ⁵ . | With the <i>application to connect submitted under clause 5.3.4 of the NER</i> . |
| (e) <u>When connecting:</u> (1) a <i>generating system <30 MW</i> , or <i>generating units totalling <30 MW</i> ; <u>or</u> (2) <u>a <i>bidirectional unit <5 MW</i> or <i>bidirectional units totalling <5 MW</i></u> , to a connection point on a distribution network ⁶ . | With the <i>application to connect submitted under clause 5.3.4 of the NER</i> . |
| (f) <u>In the following circumstances, to the extent that previously provided information requires updating⁷:</u> (1) <u>after completion of commissioning tests or tests conducted under NER 5.7.3;</u> (2) <u>when the <i>Generator or Integrated Resource Provider</i> becomes aware that the information is incomplete, inaccurate or out of date; or</u> (3) <u>on request by AEMO or the NSP, where they consider the information is incomplete, inaccurate or out of date.</u> | <u>Within 3 months of completion of testing.</u> <u>On becoming aware of incomplete, inaccurate or out of date material, or on receipt of a request, as applicable</u> |

~~AEMO needs to be able to model power system behaviour on an ongoing basis to ensure that it can fulfil its obligations to operate the power system in accordance with the NER. To achieve this, AEMO needs up-to-date information about the behaviour of plant connected to the power system. Generators should ensure that all models and other information provided to AEMO in accordance with these Guidelines remain up-to-date, because if AEMO reasonably considers that:~~

- ~~• the analytic parameters for modelling of a generating unit or generating system are inadequate; or~~
- ~~• available information, including results from a test of a generating unit or generating system under clause 5.7.6(a) of the NER, are inadequate to determine parameters for an applicable model;~~

~~AEMO may direct an NSP to require a Generator to conduct a test under clause 5.7.6(a) at the Generator's cost.~~

~~Furthermore, a Generator who has previously provided adequate RMS models and associated information to AEMO will be required to provide up-to-date EMT models to AEMO if required by an NSP who carries out a system strength impact assessment.~~

~~A proposed material alteration to an existing *generating system* or *integrated resource system* covered under paragraph (c) in the table may require the provision of models for the entire *plant conforming with these Guidelines*, even where the existing *legacy plant* and equipment is not itself altered. Further guidance is provided in Section 4.8.4 below.~~

⁴ See NER clause 5.3.9(b)(2) of the NER.

⁵ See NER clause S5.2.4 of the NER.

⁶ See NER clause S5.5.6 of the NER.

⁷ See NER S5.2.4(d)

2.2. Network Service Providers

The circumstances in which NSPs must provide models and other information to AEMO and any other relevant NSPs in respect of their *network elements* under these Guidelines are specified in ~~NER clause S5.5.7(b1)(1)(ii) of the NER~~ and are, in summary:

| Requirement | Timing |
|--|--|
| (a) Where there is, in AEMO's reasonable opinion, a risk that an alteration to a <i>network element</i> or the <i>connection</i> of any new or additional equipment to the <i>network</i> will: <ol style="list-style-type: none"> (1) adversely affect <i>network capability, power system security, quality or reliability of supply, or inter-regional power transfer capability</i>; or (2) adversely affect the use of a <i>network</i> by a <i>Network User</i>⁸. | Within 20 <i>business days</i> of AEMO's notice of the impact described in sub-paragraph (1) or (2). |
| (b) Where there is, in AEMO's reasonable opinion, a risk that an NSP's <i>plant</i> or equipment will: <ol style="list-style-type: none"> (1) adversely affect <i>network capability, power system security, quality or reliability of supply, or inter-regional power transfer capability</i>; (2) adversely affect the use of a <i>network</i> by a <i>Network User</i>; or (3) have an <i>adverse system strength impact</i>⁹. | Within: <ul style="list-style-type: none"> • 20 <i>business days</i> of AEMO's notice of the impact described in sub-paragraph (1) or (2); or • 15 <i>business days</i> of AEMO's notice of the impact described in sub-paragraph (3). |
| (c) Where, in AEMO's reasonable opinion, information of the type described in NER clause 4.2.4(o) is required to enable another NSP to conduct a <i>system strength impact assessment</i> ¹⁰ . | Within 15 <i>business days</i> of AEMO's request to provide the relevant information. |

2.3. Network Users

The circumstances in which *Network Users* must provide models and other information to AEMO and relevant NSPs in respect of their *plant* under these Guidelines are specified in ~~NER clause S5.5.7(b1)(i1)(iii) of the NER~~ and are, in summary:

| Requirement | Timing |
|---|--|
| (a) Where there is, in AEMO's reasonable opinion, a risk that a <i>Network User's plant</i> will: <ol style="list-style-type: none"> (1) adversely affect <i>network capability, power system security, quality or reliability of supply, or inter-regional power transfer capability</i>; (2) adversely affect the use of a <i>network</i> by a <i>Network User</i>; or (3) have an <i>adverse system strength impact</i>¹¹. | Within: <ul style="list-style-type: none"> • 20 <i>business days</i> of AEMO's notice of the impact described in sub-paragraph (1) or (2); or • 15 <i>business days</i> of AEMO's notice of the impact described in sub-paragraph (3). |
| (b) Where, in AEMO's reasonable opinion, information of the type described in NER clause S5.3.1(a1) of the NER is required to enable an NSP to conduct a <i>system strength impact assessment</i> ¹² . | Within 15 <i>business days</i> of AEMO's request to provide the relevant information. |
| (c) Where the <i>Network User</i> proposes to alter <i>connected plant</i> and that alteration will affect the performance of the <i>plant</i> relative to the technical requirements in NER S5.3.11¹³. | With the submission made under NER 5.3.12(b) |

⁸ See ~~NER clause 4.3.4(o) of the NER~~.

⁹ See ~~NER clause 5.2.3(j) of the NER~~.

¹⁰ See ~~NER clause 5.2.3(k) of the NER~~.

¹¹ See ~~NER clause 5.2.4(c) of the NER~~.

¹² See ~~NER clause 5.2.4(d) of the NER~~.

¹³ See ~~NER 5.3.12b)~~

| Requirement | Timing |
|---|---|
| (e)(d) Before connecting any new or additional equipment to a <i>network</i> ¹⁴ . | With the <i>application to connect</i> submitted under clause 5.3.4 of the NER . |

A proposed material alteration to a *Network User's* existing *plant* covered under paragraph (c) in the table may require the provision of models for the entirety of the *Network User's* equipment conforming with these Guidelines, even where the existing legacy plant and equipment within the installation is not itself altered. Further guidance on this matter is provided in Section 4.8.4 below.

2.4. Market Network Service Providers

The circumstances in which MNSPs must provide models and other information to AEMO and relevant NSPs in respect of their *plant* or equipment under these Guidelines are specified in ~~NER clause S5.5.7(b1)(1)(iv) of the NER~~ and are, in summary:

| Requirement | Timing |
|---|---|
| (a) Where there is, in AEMO's reasonable opinion, a risk that MNSPs' <i>plant</i> or equipment will: <ol style="list-style-type: none"> (1) adversely affect network capability, power system security, quality or reliability of supply, inter-regional power transfer capability; (2) adversely affect the use of a <i>network</i> by a <i>Network User</i>; or (3) have an adverse system strength impact¹⁵. | Within: 20 <i>business days</i> of AEMO's notice of the impact described in sub-paragraph (1) or (2); or 15 <i>business days</i> ' of AEMO's notice of the impact described in sub-paragraph (3). |
| (b) Where, in AEMO's reasonable opinion, information of the type described in NER clause S5.3a.1(a1) of the NER is required to enable an NSP to conduct a <i>system strength impact assessment</i> ¹⁶ . | Within 15 <i>business days</i> ' of AEMO's request to provide the relevant information. |
| <u>(c) Where the MNSP proposes to alter <i>connected plant</i> and that alteration will affect the performance of the <i>plant</i> relative to the technical requirements in NER S5.3a.7¹⁷</u> | <u>With the submission under NER 5.3.12(b).</u> |
| (e)(d) Before connecting any new or additional equipment to a <i>network</i> ¹⁸ . | With the <i>application to connect</i> submitted under clause 5.3.4 of the NER . |

A proposed material alteration to an MNSP's existing *plant* covered under paragraph (c) in the table may require the provision of models for the entirety of the *market network service facility* conforming with these Guidelines, even where the existing legacy plant and equipment within the *facility* is not itself altered. Further guidance on this matter is provided in Section 4.8.4 below.

2.5. NSCAS Tenderers

The circumstances in which ~~prospective~~ NSCAS tenderers must provide models and other information to AEMO in respect of their *plant* or equipment under these Guidelines are specified in ~~NER clause S5.5.7(b1)(1)(vi) of the NER~~, namely when tendering to provide NSCAS under

¹⁴ See ~~NER clause S5.3.1(a1) of the NER~~.

¹⁵ See ~~NER clause 5.2.3A(a) of the NER~~.

¹⁶ See ~~NER clause 5.2.3A(b) of the NER~~.

¹⁷ See ~~NER 5.3.12b)~~

¹⁸ See ~~NER clause S5.3a.1(a1) of the NER~~.

~~NER clause 3.11.5 of the NER~~¹⁹. The models and information must be provided to AEMO with an NSCAS expression of interest.

2.6. Prospective SRAS Providers

The circumstances in which prospective *SRAS Providers* must provide models and other information to AEMO in respect of their *plant* or equipment under these Guidelines are specified in ~~NER clause S5.5.7(b1)(1)(vii) of the NER~~, namely when tendering to provide *SRAS* under ~~NER clause 3.11.9 of the NER~~²⁰. The models and information must be provided to AEMO with a tender for the provision of *SRAS* or, where AEMO makes a direct request for an offer for the provision of *SRAS*, in response to that request.

3. Models and data requirements

Changing *plant* technology in the *power system* has ~~introduced~~ increased the need for AEMO and NSPs to have a deeper understanding of all equipment *connecting* to the grid, including smaller *plant*, which in aggregate, can affect the *power system security* and *reliability*.

3.1. ~~Generators, Integrated Resource Providers, NSPs, Network Users, and MNSPs~~

On each occasion that a *Generator*, *Integrated Resource Provider*, NSP, ~~Network User~~ or MNSP is required under the NER to provide models and other information to AEMO and an NSP²¹, they must provide:

- ~~c~~Completed ~~Power System Design Data Sheets and Power System Setting Data Sheets~~ Data Sheets;
- ~~s~~Site-specific RMS models of all *plant* that comply with these Guidelines, including:
 - model block diagrams; and
 - model source code;
- ~~s~~Site-specific EMT models of all *plant* that comply with these Guidelines;
- ~~a~~A RUG for both RMS and EMT models in the template specified in the Releasable User Guide Template²²; and

¹⁹ See ~~NER clause 3.11.5(b)(5) of the NER~~.

²⁰ See ~~cl a-NER use 3.11.9(g) of the NER~~.

²¹ In the case of models and information required to be provided by an NSP, this is to be read as providing them to another NSP.

²² Available online at: https://www.aemo.com.au/-/media/Files/Electricity/NEM/Network_Connections/Transmission-and-Distribution/Template-for-preparation-of-a-Releasable-User-Guide.docx that AEMO expects the Releasable User Guide Template to be *published* prior to the expiry of the consultation on this document.

- R2 test report, and pre-commissioning model confirmation test report²³ prior to a hold point test as required by the relevant R2 commissioning test procedure, and-
- R2 test report.

3.2. Network Users (for loads)

On each occasion when a *Network User* is required under the NER to provide load dynamic models and other information to AEMO or an NSP in accordance with these Guidelines, they must provide:

- generic models, such as IEEE ZIP load models, or composite load models, with the model parameters selected appropriately based on the configuration of the *Network User's* facility; or
- site-specific detailed RMS models of the *Network User's* facility that comply with these Guidelines, including:
 - model block diagrams; and
 - model source code; or
- site-specific EMT models of the *Network User's* facility that comply with these Guidelines, or
- hybrid models of the *Network User's* facility containing both generic models and site-specific detailed models.

The following supplementary documents must be provided along with the *load* models:

- completed Data Sheets; and
- a RUG for RMS and EMT models where site-specific detailed models are required.

AEMO and the NSP must determine the most appropriate modelling option for each *Network User's facility* on a project-specific basis, having regard to the following factors, which should be considered in combination and in all relevant circumstances, as no single factor is necessarily definitive:

- the susceptibility / sensitivity of *load* components to controller instability and change of *power system* operating conditions, and the size of those components, where more detailed models may be required for *loads* with larger components that have higher susceptibility or sensitivity;
- the intended operation philosophy, or service provision to *power system* operation, of the *Network User's facility*, where more detailed models may be required for *loads* with a more sophisticated operation philosophy, or service provision;
- electrical proximity to other *Network Users' plant* which might be affected by the behaviour of the *facility*, where more detailed models may be required for *loads* in closer proximity to other relevant *plant*; and
- any other factor which AEMO or the NSP reasonably consider to be relevant for *power system* simulations necessary to meet their NER responsibilities.

²³ Depending on the expected impact of the *plant* on the *power system*, pre-commissioning model confirmation results may be required before the *connection* can proceed.

The composite load model refers to a composite presentation of the *Network User's facility*. An example of such a composite representation is the CMLDxx model family offered by PSS@E. Other forms of composite load model may be used, subject to AEMO and NSP's agreement.

The hybrid load model refers to a model where AEMO and the NSP require only a portion of the *load* to be modelled with site-specific detailed models. The rest of the *facility* may be modelled with generic models. For the *load* components that are required to be modelled with site-specific detailed models, the Applicant must provide both RMS and EMT models to AEMO and the NSP.

The NSP may require the Applicant to provide an EMT model of the whole *facility*, including *load* components modelled by generic models and detailed models, provided that any such a requirement does not result in the Applicant needing to acquire more information than is necessary to develop the generic RMS models for the corresponding *load* components.

3.3. NSCAS Tenders and SRAS Providers

On each occasion that an ~~an prospective~~-NSCAS ~~t~~Tenderer or prospective SRAS Provider is required to provide models and other information to AEMO, they must provide the models and other information specified in Section 3.1 except where they:

- ~~Had~~have provided the necessary models and information to AEMO within the previous three years and AEMO had indicated at the time these were acceptable;
- ~~A~~are not proposing to make any changes to the components of the *plant* or proposed *facility* within the intended period of any proposed agreement for the provision of NSCAS or SRAS (as applicable); and
- ~~N~~o changes are likely to occur to the operation of *plant* (regardless of whether they are owned by the relevant ~~prospective~~-NSCAS ~~t~~Tenderer or prospective SRAS Provider) that will impact the proposed NSCAS or SRAS (as applicable) within the intended period of any proposed agreement for the provision of NSCAS or SRAS (as applicable),

~~AEMO will not require additional models and information, however,~~ AEMO may require further clarifications on the models or information previously provided, in which case the relevant ~~prospective~~-NSCAS ~~t~~Tenderer or prospective SRAS Provider will need to respond within the ~~any~~ timeframe reasonably requested by AEMO ~~at the time~~.

1.4.3.4. Exemptions

The requirements ~~proposed~~ in these Guidelines will apply for all *power system* conditions and model types, but there are circumstances where AEMO and an NSP may exempt an Applicant from having to provide the full complement of models and other information specified in Sections 3.1, ~~or~~ 3.2 or 3.3 (as applicable). Table 3 details the circumstances where AEMO and the NSPs may exempt an Applicant:

Table 3 Grounds on which exemption may be granted

| Conditions | Reasoning | Exemption |
|--|---|-------------------------|
| <i>Plant size is ≤5 MVA and the connection point's aggregate SCR^A > 10</i> | Impact of the proposed <i>plant</i> on <i>network</i> and surrounding <i>plant</i> would be minimal. Proposed <i>plant</i> unlikely to be impacted by low system strength. | EMT model not required. |

| Conditions | Reasoning | Exemption |
|--|--|---|
| <i>Plant size < 1 MVA</i> | Impact of the proposed <i>plant</i> on <i>network</i> and surrounding <i>plant</i> would be insignificant. | No modelling information required. |
| <u>Project-specific exemption for load facilities assessed by AEMO and NSP^B</u> | <u>Taking account of all relevant factors including load size and applied technologies, AEMO and NSP consider the facility is unlikely to have any material adverse impact on other Network Users or power system operation.</u> | <u>Load dynamic models not required</u> |

A. As assessed by the connecting NSP accounting for all nearby *plant* that can reasonably impact SCR at the *connection point* under consideration.

B. Where applicable, to be assessed in accordance with the [system strength impact assessment guidelines](#).

Applicants whose *plant* meets the plant size conditions specified in Table 3 need not apply to AEMO for exemption unless their connecting NSP requires them to do so. ~~Hence,~~ Applicants who consider that they ~~should be exempt~~ qualify for exemption from having to provide the full complement of models and other information must approach their connecting NSP to seek advice on whether an application for exemption is required. If advised by the connecting NSP that it is, the Applicant must apply for exemption to AEMO and the connecting NSP using the form contained in Appendix A.

Following consideration of an application for exemption, AEMO must:

- ~~a~~Accept or reject it;
- ~~p~~Propose options for the Applicant to consider; or
- ~~r~~Request further information.

4. Model adequacy

AEMO and NSPs use *plant* models for many purposes. The assessment of the suitability of proposed *plant* and its proposed *performance standards* and determination of *plant* capability to achieve its *performance standards* are the ones that most *Registered Participants* are aware of, and is the main reason why they must provide models, but this is just one of many. Others include the ongoing management and assessment of *power system security*, such as short-term operational planning and development of *constraint* equations, stability assessment, use in long-term *power system* planning, the assessment of other proposed connections, procurement of *ancillary services*, simulations for the purpose of training and incident investigations.

For these reasons, models must demonstrate the degree of adequacy and accuracy specified in these Guidelines.

For each *plant* being assessed, the Applicant must provide a site-specific model in the appropriate tool and consisting of components necessary to facilitate accurate studies for the specific phenomenon under consideration.

Subject to any requirements specified elsewhere in these Guidelines, it is expected that models provided to AEMO and ~~the~~ NSPs are an accurate representation of *plant* and *plant* responses for multiple, successive Disturbances. This does not require those providing models to consider every conceivable combination of Disturbances. For example, when submitting models for the purpose of connection studies, the submitting party can evaluate responses to singular or limited combinations of Disturbances only to the extent that they are relevant to the *access standard* being considered. Appendix C outlines the physical components to be included in a model based on the studies being performed. As load flow and fault level studies are typically

based on Newtonian solution methods, rather than physical components, these study types are excluded from the tables in Appendix C.

Due to the continuous evolution of technology, the tables in Appendix C may not cover every key component present in all *plant*. If a *plant* or component not specified in those tables is determined by AEMO and the NSP to provide a significant contribution to the result of a study, AEMO and the NSP may request that this *plant* or component be included in the model submitted by the Applicant.

4.1. Load flow model requirements

Adequate load flow models must represent the *plant* **S**teady **s**tate conditions for the full operating envelope in the software package nominated by AEMO and the NSP.

Where applicable and where the RMS tool allows, load flow models of *plant* must include:

Table 4 Load flow model inclusions

| Plant element | Including |
|--|---|
| Generating <u>units or bidirectional units</u>^A, reactive support <i>plant</i> | MVA base |
| | Source impedance, including positive, negative and zero sequence |
| | Active and reactive power profile ^B |
| | Voltage control scheme |
| | Active / reactive power capability curve in PSS@E .qcp (preferred) or text format |
| Plant transformers^A (including step-up, intermediate and connection point) | MVA base and ratings |
| | Winding vector group |
| | All winding voltages |
| | Winding impedances, including positive, negative and zero sequence |
| | Grounding arrangements and impedances |
| | Connection code |
| | Magnetising impedances |
| | Tap location, number and voltage range |
| | Voltage control scheme |
| HVDC links | Plant ratings, voltages and impedances |
| | Control modes, including target control quantities |
| | Base voltages levels and target voltage levels |
| | Transformer impedances, voltages, tap ranges, bases |
| | Firing angle ranges (for applicable technologies) |
| | Commutating impedances (for applicable technologies) |
| Reticulation <u>n</u>Network^A | Positive, negative and zero sequence impedance |
| Shunt components | Switched shunts |
| | Fixed shunts |
| | Switched shunt voltage control scheme |
| Loads | Active and reactive power levels, in most appropriate format (power / impedance / current) |

A. For *plant* consisting of several distributed *generating units or bidirectional units*, aggregation principles outlined in Section 4.7 must be used.

B. Consistent with the plant's performance standard

The load flow model contents must be consistent with the information provided by the Applicant in the RUG.

4.1.1. Format

Section 4.3.11 outlines the model format requirements for load flow models when represented in RMS simulation tools.

4.2. Fault level model requirements

Provision of short circuit data for the *plant* to IEC 60909:2016 is sufficient to meet the requirement for short circuit analysis. This short circuit data should be integrated into the load flow model to the extent this is possible in the host software platform.

4.2.1. Format

Section 4.3.11 outlines the model format requirements for fault level models when represented in RMS simulation tools.

4.3. RMS and EMT stability model requirements

The following criteria apply before an RMS or EMT model can be accepted for assessment by AEMO and the NSP. The requirements specified in this section apply to all *plant* except those in Section 4.3.2, which only apply to *plant* participating in the FCAS market or the provision of other forms of *frequency* control, such as in a future fast frequency response market.

4.3.1. General requirements

Transient models provided under ~~NER clause S5.2.4(b) of the NER~~ must define the site-specific electromechanical and *control system* performance of components comprising *plant* under Steady State, set-point change and Disturbance conditions for all levels of system strength and energy source availability that the *plant* is rated to operate.

That *plant* includes:

- ~~The *generating unit or any other* primary or relevant secondary *plant* within the *generating system or integrated resource system* that may affect the overall interaction (*active power, reactive power or voltage*) of the *generating system or integrated resource system* with the *power system* (e.g. *reactive power compensating plant*); and-~~
- ~~A~~ any dynamic *reactive power or voltage* compensation *plant* within the *network* that can have an impact on transient and *voltage* stability.

Parameters of transient models developed for new and modified ~~*generation or integrated resource connections*~~ *generating systems or integrated resource systems* (including any supervisory control) should be refined through extensive connection studies. *Plant* model and parameters must be assessed through the NSP and AEMO due diligence process to be qualified as R1 data.

RMS and EMT models and parameters submitted to AEMO and the NSP must conform to the following general requirements before being considered for assessment.

Model compatibility and stability

Models must:

- ~~b~~Be compatible with the *power system* software simulation products specified by AEMO and the NSP;
- ~~w~~Work for a range of dynamic simulation solution parameters rather than for specific settings only;
- ~~b~~Be numerically stable for the full operating range including a wide range of grid SCR and grid and fault X/R ratio;
 - any model validity limitations due to system impedance or strength should be clearly defined within the RUG;
- ~~b~~Be numerically stable up to a simulation time of ~~at least~~up to five minutes (have *voltage*, *frequency*, *active power* and *reactive power* remaining constant for dynamic simulation runs with no Disturbance); ~~and~~
- ~~n~~Not show characteristics that are not present in the actual *plant* response; ~~;~~

Model composition and operating range

Models must:

- ~~b~~Be a model of the specific *plant* being considered;
- ~~i~~Include any relevant non-linearities, such as limits, arithmetic or mathematical functions, deadbands or saturation, ~~etc.~~;
- ~~r~~Represent the *generating system* or *integrated resource system* and reactive compensation *plant* performance for all possible Steady State output and system strength levels where the *plant* would be in operation;
- ~~r~~Represent *plant* response for set-point changes including *active power*, *reactive power*, *power factor*, *voltage* and *frequency*, including associated *ramp rates*; ~~;~~
- ~~r~~Represent the *generating system* or *integrated resource system* and reactive compensation *plant* performance for all possible values of energy source variation where the ~~generating unit or generating system~~ or *integrated resource system* would be in operation;
 - ~~f~~For *generating units* or *bidirectional units* with an inherently variable power source, the ability to vary the energy source strength must be maintained throughout the simulation study;
- ~~r~~Represent all *plant* within the *generating system* or *integrated resource system*, including *generating units*, *bidirectional units*, governors, park controllers, *tap-changing transformers*, and *reactive power* compensating *plant*;
 - ~~R~~Relevant protection relays must be included in the model, explicitly where practically possible; ~~;~~
- ~~r~~Represent delays between *plant* elements (e.g. SCADA, PLC and park controller communication delays) that have an impact on the performance of the *plant*;

- ~~i~~Include adequate modelling of the mechanical components of the *plant*, to the extent that such mechanical components have a significant effect on the stability of the *plant* and its response to ~~power system disturbances~~Disturbances;
- ~~i~~Include models of *generating unit* ~~or~~ *bidirectional unit* energy storage components that would be affected by Disturbances;
- ~~r~~Represent *plant* response to any runback scheme or special protection scheme in which the *plant* participates in;
- ~~R~~represent *plant* performance accurately within the normal dispatch range between minimum and maximum *active power* output, but must also be able to be initialised at any *active power dispatch* ~~down to 0 megawatts~~in the normal dispatchable operating range of the *plant* in MW;
 - Linearised models that are accurate only for a single operating point are not acceptable²⁴; and
- ~~initialise~~ ~~Can be initialised~~ correctly (for example, for RMS models from load flow) if dispatched to a power level lower than that available from the ~~energy~~fuel source.

Model multiple operating modes and control functions

A model must:

- Represent all modes of operation that the physical *plant* is capable of operating in. For example, if applicable to the physical *plant*, the model must be able to represent:
 - ~~g~~Generation, synchronous ~~condensor~~condenser and pump modes for relevant hydro-electric generation technologies, e.g. pumped storage;~~;~~
 - ~~v~~Voltage control, *power factor* control and *reactive power* control modes; ~~and~~;
 - ~~a~~Activation/deactivation of *frequency* control and fast *frequency* response features.

All automatic changes to operating modes that occur in reality should happen automatically within the model. Where automatic mode switchover cannot occur, operating mode changes must be based on configuration file or variable changes. It is not acceptable to require a separate model for each operating mode.

- Represent the simultaneous control functions that are active within the physical *plant* without the need to change model setup, variables or configuration parameters.
 - For example, a model must be able to represent both *active power* control and *frequency* control functions operating simultaneously.

Mid- and long-term dynamics

Any dynamic models provided for a *plant* must be adequate for simulation of the response of equipment, such as onload tap changer controllers, turbine governors, over-excitation or stator current limiters and any other thermal, *voltage* or *frequency* related controller with a time-~~;~~ delayed response up to 120 seconds.

²⁴ AEMO understands that this may be difficult to achieve for some plant with complex thermal componentry. Where the required accuracy cannot be met, AEMO will consider an application for an adjustment to this requirement in accordance with the Alternative Process detailed in Section 8.

Additionally, models must not change appreciably²⁵ during a flat-run (no Disturbance) simulation. Simulation durations for no-Disturbance studies range from 10 to 300 seconds (the latter to verify long-term Steady State stability).

4.3.2. Requirement for detailed load models

AEMO and the NSP may require more detailed load models than IEEE ZIP load model or composite load models, in the following circumstances:

- it is necessary to demonstrate compliance to relevant *performance standards* related to *load transient performance* following *contingency events*, or
- the load has the potential to have a significant impact on *power system* operation, or and the operation of nearby *Network Users*, as determined by AEMO and the NSP under the *system strength impact assessment guidelines*, or
- if determined by AEMO and the NSP after considering the factors listed in Section 3.2 of these Guidelines.-

Relevant model requirements in the following sub-sections of Section 4.3 of these Guidelines only apply to detailed load models, and not to the IEEE ZIP load model or the composite load models, unless specifically stated otherwise.

4.3.3. Requirements for Remedial Action Schemes

AEMO and the NSP may require RAS models where triggering of the scheme could have a material impact on the *power system*. These models should encompass:

- Communication, measurement, filtering and processing delays (for example, intentional time delays like timer settings, or inherent delays like relay operating times).
- Calculation algorithms and logic/tripping sequences.
- Output actions including associated delays.
- Parameters, signals and status to be monitored.

Where possible, RAS models should be represented with standard objects from the model library of the relevant simulation software²⁶.

4.3.4. Additional requirements for frequency stability studies

For *frequency* stability studies, models must also:

- Provide an accurate response of the *plant* to changes in *network frequency*, and *active power generated/supplied to or consumed from the network, as determined by the available power*, regardless of whether it is enabled as FCAS-_i;
- Take into account both central controllers and distributed *plant* if an aggregated service is used to provide FCAS-_i;

²⁵ State changes in RMS models or noise/chatter in both RMS and EMT models are not expected to occur for flat-runs.

²⁶ Refer to the Remedial Action Scheme Guidelines

- Be an accurate representation of the maximum rate of change of *frequencies* that the *plant* is capable of operating with;
 - For absolute changes in network frequency within the *frequency operating standard* where the *plant* is connected. If the *performance standards* of the *plant* exceed these limits, the models must be accurate for the full range of *network frequency* in which the *plant* can operate;
- Represent the *frequency* and speed filtering applied in the governor system controller and/or time delays in control variable measurement transducers;
- Represent any controller settable control variable position limits, ramp rate limits or deadbands;
- Include any mechanical actuator limits, for example e.g., fuel valve open/close rate of change limits, pitch limits, open/close position limits, exhaust temperature limits, internal turbine limits, active power limits or other physical limits within the *control system* that cause a limit on power output and/or fuel flow;
- Include fuel valves and fuel valve actuators that have control dynamics in addition to the *control system*, where these can affect the stability of the governing system or have an appreciable effect of the accuracy of the model must be included in the model;
- Include non-linear fuel flow to valve position and/or non-linear fuel flow to power characteristics, where an efficiency characteristic has an appreciable effect of the accuracy of the model;
- Include large Disturbance controls, such as intercept valve control on steam turbines, load rejection detection, acceleration control, power load unbalance detection and pre-emptive overspeed detection.
- Include external (to the governor/power *control system*) control action (e.g. from *Generator or Integrated Resource Provider* SCADA system), to regulate the power set-point during *frequency* Disturbances when enabled and not enabled for FCAS-;
- Include control mode changes or control gain changes that may be triggered from *network* Disturbances (for example, in the case of islanding situations where the *network frequency* may vary within the normal contingency bands, or where special logic is used to boost FCAS capability);
- Represent any automated deployment of FCAS (specifically fast raise/lower and slow raise/lower service) where this is provided in addition to (or when a *generation generating system or integrated resource system* has been *dispatched* for a specified FCAS amount) or by normal governor action with additional algorithms or controls. Where other control logic is used (e.g. SCADA/AGC) to deploy the FCAS by direct control of the power set-point during a *frequency* Disturbance this must also be included in the model-; and
- Represent the fuel delivery system dynamics where this has a material influence on the power output during and after a *frequency* Disturbance and within a timeframe up to five minutes from the initiating Disturbance, or where the fuel delivery system is common to multiple *units generating units*, or derived from the *generation system or integrated resource system* -in other *production units* within a *plant* such that changes in *active power generation* on one *generating unit-unit* can cause a change on another *unit generating unit*. Some examples of these are:

- Hydro **generating**-units being supplied from a common penstock/surge tank.
- Combined cycle *plant* where a heat recovery system from gas turbines is used to generate steam for a steam **generating**-unit.
- Gas turbines where the turbine mechanical power decreases with *frequency*.

4.3.5. RMS model-specific requirements

The following are requirements for RMS dynamic models supplied to AEMO and the NSP:

- Models must have a bandwidth of at least 0.05 Hz to 10 Hz (for that part of the response that is linear) and settle to the correct final value for the applicable *power system* conditions and applied Disturbance(s);
- Models must initialise themselves in a Steady State consistent with the system conditions in the network load flow model. When these preconfigured system conditions are beyond *plant* operational limits or otherwise not consistent with valid operating conditions for the *plant*, the model must warn the user by way of a message to the progress output device;
- Where special tuning of the load flow case is required to replicate expected operating conditions with given control set-points, acceptability of the tuning procedure must be agreed to by AEMO and the NSP and documented in the RUG. Where a script is provided to assist with this procedure, it must be provided in the Python language;
- Changes to the Steady State operating point for the modelled element must not require changes to any external dynamic settings (for example, in PSS@E, CONs, and ICONs) except where the change cannot be adequately inferred from the network load flow case. Where the Steady State configuration of the model cannot be uniquely inferred from load flow (e.g. for example, Steady State wind speed when operating a wind turbine at 100% output), additional configuration parameters may be provided in runtime settable variables. Reasonable default values must be provided or inferred for any such parameters;
- For models where a park controller is included, the park controller must remain functional when one or more (but not all) *plant* elements regulated by the park controller are out of service.
- When initialised at a valid Steady State operating point for the *plant* within operational limits, the model must correctly calculate state derivatives (for example, in PSS@E, models must not cause 'INITIAL CONDITIONS SUSPECT' messages at simulation start), unless there is a valid reason why this cannot occur (e.g. for example, the derivative of state of charge of a depleted battery initialised in charging mode). This will generally be the case when the derivative calculated for each state variable is no greater than 0.00001²⁷, or 0.01 times the initial value of the state variable (whichever is greater), in absolute value at time of initialisation;
- To avoid excessive simulation burden when integrating RMS models into OPDMS and DSA tools, the minimum permissible values of the numerical integration time step and acceleration factors are 1 ms and 0.2, respectively;

²⁷ PSS@E considers any state variable initialised with an absolute value less than 0.001 to be 'practically zero' and compares the calculated rate of change with the fixed threshold 0.01 for such variables. -Otherwise, the ratio of the rate of change to the initial value is compared with the 0.01 threshold.- In the worst case, an initial state equal to 0.001 will trigger a 'suspect' initial condition if its rate of change exceeds 0.00001.

- Models must be compatible with dynamic simulation frequency dependency functions that the tool provides (for example, the Network Frequency Dependence option in PSS®E);
- RMS model outputs in terms of the voltage, frequency, active power and reactive power must be reasonably constant and consistent when doubling and halving the recommended time step;
- Models must be rigorously tested within a NEM-wide simulation for integration compatibility for large-scale *power system* studies. Experience has shown that SMIB simulations do not always reveal new models' adverse interactions with other models in the system; and
- Models must not write messages to the console during a simulation run other than in response to error conditions to signal abnormal events (such as a protection trip) or when additional model-specific output has been requested by the user. The model RUG must include sufficient description for the error or warning messages built into the model, which can be interpreted by the NSP and AEMO.

4.3.6. EMT model-specific requirements

The following are requirements for EMT dynamic models supplied to AEMO and the NSP:

- Have a bandwidth of at least DC to 10 kHz and settle to the correct final value for the applicable *power system* conditions and applied Disturbance(s);
- Be based on *plant* design data and rigorously tested against factory acceptance tests for the corresponding version of *plant*;
- Include detailed representation of all inner and outer control loops for the *plant*²⁸;
- Represent all electrical, mechanical and control features pertinent to the type of study being done²⁹;
- Have the full representation of switching algorithms of power electronic converters for power system harmonic studies³⁰;
- Have all pertinent *protection systems* modelled in detail for *power system* transient and voltage stability analysis, including balanced and unbalanced fault conditions, *frequency* and *voltage* Disturbances, and multiple fault conditions and can disable the *protection systems* if required;
- Be configured to match expected site-specific equipment settings;
- Allow *plant* capacity to be scaled;
- Transient stability EMT-type models must operate with a time-step greater than or equal to 1_ microsecond, ideally consistent with the switching frequency of the *plant*;

²⁸ The model cannot use the same approximations classically used in transient stability modelling, and should fully represent all fast inner controls, as implemented in the real equipment. It is possible to create models which embed (and encrypt) the actual hardware code into an EMT component. This is the recommended type of model.

²⁹ This may include external voltage controllers, plant level controllers, customized PLLs, ride-through controllers, SSCI damping controllers or others. Further details of required electrical and mechanical components are provided in Appendix C.

³⁰ The NSP and AEMO may require the Applicant to provide the fully switched model of the plant for other types of studies, and the performance overlay between the average model and the fully switched model to verify the accuracy and adequacy of the average model.

- For EMT-type models used for harmonic analysis or real-time EMT simulations, time-steps must be such that they allow for an accurate representation of the switching algorithm of semiconducting devices;
- Allow model re-entry³¹ to facilitate integration into larger system studies;
- Support multiple-run features to facilitate iterative studies;
- Allow multiple instances of the model within the same simulation;
- Be capable of self-initialisation, with initialisation to user defined terminal conditions within three seconds of simulation time;
- Warn the user by way of a message to the progress output device when the system conditions are beyond *plant* operational limits or otherwise not consistent with valid operating conditions for the *plant*; and
- Clearly identify the manufacturer's EMT model release version and the applicable corresponding hardware firmware version.

Multiple voltage disturbances

Where relevant to load models, the following modelling requirements for multiple voltage Disturbance ride-through capability are applicable to user-defined site-specific EMT load models, for example where the load facility is expected to demonstrate compliance with relevant fault ride through capability performance standards.

The EMT model provided must account for the most restrictive³² electrical, mechanical, or thermal protection of the *plant* with respect to multiple *voltage* Disturbances in quick succession, and calculate dynamically and accumulatively the impact of multiple *voltage* Disturbances, including but not limited to the following factors:

- Heat dissipation across the dynamic braking resistors (if applicable);~~);~~
- Capability of auxiliary supplies, e.g. for example, uninterrupted power supply (UPS);~~);~~
- Torsional stress protection on shaft drive train and prime mover (if applicable);~~);~~³³
- Protection associated with thermal design limits of the integral assembly of the *plant*; ~~and~~
- Any other relevant electrical, mechanical or thermal protection.

Note that these requirements apply only to EMT models as the simplifications of RMS plant models may result in inaccurate activation of fault ride-through mechanisms for unbalanced faults.

³¹ This refers to the ability for a model to use the PSCAD™/EMTDC™ Snapshot feature, whereby the states and variables in an EMT model can be frozen in time and saved in a Snapshot file. The model can then be initialised in this state in subsequent simulations. For more information, please consult the "Initialization and Initial Conditions" section of the PSCAD™ online help system.

³² It is the Applicant's responsibility to determine which protection element(s) will be the most limiting factor for multiple fault ride-through.

³³ This is a relatively uncommon protection relay – the *Generator* must determine whether the exclusion of this relay from the model has a material impact on model accuracy.

4.3.7. Accessible variables

Where applicable, all models must allow alteration to the following:

- All applicable set-points within all *plant* including (must be adjustable before and during a simulation run):
 - Active power_u
 - Reactive power_u
 - Voltage_u
 - Power factor_u
 - Frequency_u

~~F~~for example, for a *generating system* or *integrated resource system* this infers access to all applicable set-points;

- Deadband, droop, delays (including communication delays) and slow³⁴ outer loop controls for any applicable control system such as *frequency* and *voltage* control;
- Ramp rates for changes in active power;
- *Voltage* and *frequency* protection settings, such as over/under *voltage* protection and over/under *frequency* protection;
- Fault ride-through activation and deactivation thresholds, including any multiple-fault ride-through limits and hysteresis levels;
- Active and reactive current injection/absorption settings during a fault;
- Number of in-service *generating units* or *bidirectional units* and reactive support *plant*, adjustable before and during a simulation run; and
- Energy source input (~~e.g.~~ for example, wind speed or irradiance), adjustable before and during a simulation run without causing any adverse impact on initialisation or dynamic performance.

Additional alterable variables may be required by AEMO or the NSP to undertake full stability impact assessment as described in the *system strength impact assessment guidelines*. ~~f.~~ For example, proportional and integral gains for inner/outer current/*voltage* control loops (including PLL, DC link current and *voltage* control, and any other control loops which can have a system strength impact). These variables can be adjusted by means of applying a real number multiplier if the actual values of these gains are preferred to remain black-boxed.

4.3.8. Model outputs

Table 5 outlines the output quantities required to demonstrate model performance for a variety of dynamic analysis scenarios. Quantities used to determine model accuracy are typically a sub-set of these quantities, and are described in Appendix D.

³⁴ Adequate for simulating actions of on-load tap changing *transformers*, static reactive *plant* switching, and 60 seconds Contingency FCAS.

Table 5 Required model output quantities

| Plant type | Plant internal quantities | Plant terminal measured quantities |
|---|---|--|
| Synchronous machines | Field current ^A Field voltage Limiter outputs ^B Mechanical power or torque Rotor angle Power System Stabiliser (PSS) output ^G Unit speed Automatic voltage regulator (AVR) output ^C Exciter output Valve position ^G Guide vane/needle positions ^G Governor control output ^G Set-point for active power ^G Set-point for voltage External protection relay(s) status ^H | Active power Total current ^E Frequency Reactive power Voltage magnitude ^E Voltage phase angle |
| Wind (generating unit) | DC link voltage and current Error/status codes ^D Generator rotor speed Active and reactive currents Mechanical torque or power Pitch angle Quantity determining FRT activation Set-point for active power Set-point for reactive power, voltage or power factor | |
| Photovoltaic (generating unit) | DC link voltage and current Error/status codes ^D Active and reactive currents Quantity determining FRT activation Set-point for active power Set-point for reactive power, voltage or power factor | |
| Battery (generating unit or bidirectional unit) | DC link voltage and current Energy storage level (if applicable) Error/status codes ^D Active and reactive currents Quantity determining FRT activation Set-point for active power Set-point for reactive power, voltage or power factor | |
| Traditional large load^K | Largest direct-online (DOL) motor slip Largest DOL motor active and reactive power Largest DOL motor terminal voltage Protection relay(s) trip status^H | |
| Inverter based load^{K,L} | DC link voltage and current Energy storage level Active and reactive current FRT entry and exit status Controller setpoints Protection relay(s) trip status^H | |
| HVDC link | DC link voltage and current Firing angle (for LCC HVDC) Switch / valve currents ^A Error/status codes ^D Active and reactive currents | |

| Plant type | Plant internal quantities | Plant terminal measured quantities |
|---|--|------------------------------------|
| | Quantity determining activation of blocking modes ^I Set-point for active power Set-point for reactive power, voltage or power factor External protection relay(s) status ^H | |
| Reactive compensation plant (such as static VAR compensators [SVCs], STATCOMs, etc.) | DC link voltage and current Shunt control status/set-points External plant set-point outputs Error/status codes ^D Active and reactive currents Quantity determining activation of blocking modes ^J Set-point for reactive power, voltage or power factor External protection relay(s) status ^H | |
| Centralised controllers (park and hybrid controllers) | Error/status codes ^D Quantity determining FRT activation Set-point for active power ^F Set-point for reactive power, voltage or power factor ^F External protection relay(s) status ^H | |

- A. In EMT models only.
- B. Relevant limiter outputs, such as over-excitation limiter, under-excitation limiter, V/Hz limiter etc.
- C. Including outputs of any compensation components.
- D. Only those error/status codes which translate into a distinct electrical system response at the **low voltage (LV)** terminals of the *plant*.
For example, normal, fault, stop, **low voltage ride-through (LVRT)** or **high voltage ride-through (HVRT)** activation, unstable mode identification etc.
- E. Both waveform and RMS values for EMT models.
- F. As sent to *generating units* or *bidirectional units* within the **generating** system.
- G. Not applicable for synchronous condensers.
- H. External discrete protection relays relevant to the *plant*. For example, for transient stability studies; this may include over- and under-voltage, over- and under-frequency, RoCoF and reverse-power protection. For black-start studies, this may be extended to include negative sequence, out-of-step, over-fluxing, loss-of-excitation and generator and unit-transformer differential protection.
- I. For line-commutated technologies, this would include the voltage-dependent current-order limit (**VDCOL**), and commutation failure (emulated in RMS models, simulated in EMT models). For both line-commutated and voltage-source technologies, blocking below certain *voltage* levels or other conditions should be modelled.
- J. Include within models the blocking response below certain *voltage* levels or other conditions.
- K. Only applicable to user-defined, site-specific load models, subject to the actual configuration of the load. For example, certain required quantities are not available when the according load component does not exist in the load facility, and does not need to be provided.
- L. The internal quantities are associated with embedded generating units or bidirectional units within the load facilities, for example, UPS within data centres, and hydrogen fuel cells within hydrogen protection facilities.

In addition to these internal and terminal quantities, models should provide access to the aggregated Reticulation Network and point-of-connection or unit transformer **low voltage (LV)** and **high voltage (HV)** to demonstrate the complete *generating system* or *integrated resource system* performance.

4.3.9. Integration compatibility

A model submitted to AEMO and the NSP for any *power system* element must operate as part of a full *power system* model alongside models of many other *power system* elements. This will inevitably include elements of the same type as the one in question, using either the same or a different release version of the same model code, submitted by the same or another *Registered Participant*.

It is, therefore, imperative that the model is capable of coexisting and operating correctly alongside other independent instances of the same model, either of the same version or with a different version number. This requires attention as a minimum to the following:

- Naming and referencing models, functions and libraries based on a version number, such that two different versions of a model of the same *plant* can run within the same simulation environment without interference;
- Creating models to work for a range of time steps and dynamic simulation parameters, rather than for specific settings only;
- Avoiding the use of global (FORTRAN COMMON) variables, including subroutine-level static (FORTRAN SAVE) variables, with persistent values, except where dynamic allocation is used to create instance-specific copies of such variables; and
- Models should, to the maximum extent practical, make use of the mechanisms provided within the host software platform to encapsulate separate model instances (for example, the pre-allocated STATES and VARs in PSS®E).

Additionally, for EMT models, integration compatibility is improved by:

- Having all *plant* and *control system* models contained within a single EMT case, rather than spanning across a simulation set.
 - Methods used to split a single *plant's* model components across several files for (typically SMIB) processing speed improvements may not be compatible with the broader case into which it will be integrated. Applicants must consult with AEMO and the NSP if simulation sets are required.
- Having dependencies on a minimal number of external files.
- Model dependencies on external files having user-settable naming references.

Models that prove problematic to integrate into larger cases will need to be rectified before AEMO and the NSP are able to accept the model for further assessment. AEMO and the NSP will work with the Applicant to identify the issues.

4.3.10. RMS model source code

Source code of the RMS simulation model must be provided to AEMO, including all elements of the *plant* that affect its dynamic response, such as:

- For a *generating system* or integrated resource system, the ~~generating~~ unit model(s).
- Supervisory controls acting on the *plant* as a whole.
- Dynamic reactive support *plant*.
- Coordination of multiple reactive support devices and hybrid facilities.
- Any other *plant* such as *transformer* tap-changers whose response can reasonably impact the overall dynamic performance of the *generating system* or integrated resource system.

The model must be written and prepared using good model writing practices utilising the most recent model writing features and capabilities for the relevant software. For example, this would include the following:

- The models of the controllers and items of *plant* must be easily identifiable~~;~~
- The code should be commented to identify major components~~;~~
- Execution of dynamic data documentation commands should not result in model crashing;

- The model code should ensure correct implementation of windup and non-windup limits; and
- The model code should implement division and square root operations in a 'safe' manner to avoid division-by-zero and similar exceptions.

Additionally, for PSS®E RMS models:

- Using models which include calls into either of the CONEC or CONET subroutines is not acceptable. These calls can be avoided by adhering to 'table driven model' conventions in the model implementation. As of PSS®E version 34, table-driven models may be associated with most power system elements;
- Execution of the DOCU command should show all model states, outputs and constants that are observable/adjustable externally. The output format of these commands should be consistent with the format of dynamic data records;
- Using identical names should be avoided for models of similar structure where the number of one of the CONs, ICONs, VARs, or STATES is different between the two models; and
- The use of auxiliary or linking files is not acceptable.

4.3.11. RMS model format

RMS models submitted to AEMO for the purposes of load flow, fault analysis and conventional transient stability studies must be compatible with PSS®E version ~~32 or 34~~ 7 or greater.

Provided an RMS model in an alternative format is readily available from original equipment manufacturers (OEMs), RMS models submitted to the connecting NSP must be compatible with the software package nominated by the NSP where an NSP uses a different RMS-type simulation tool, such as DigSILENT Power-Factory. RMS models should not have dependencies on additional external commercial software.

AEMO accepts RMS model source code natively developed in FORTRAN 90 or higher. FLECS code is no longer accepted.

4.3.12. EMT model format

Minimum format requirements up to 14 July 2024

EMT models provided to AEMO and the NSP up to and including 14 July 2024 must be compatible with PSCAD™/EMTDC™ version 4.65.0 and above and Intel ~~Visual~~ FORTRAN Compiler Classic version 2021.x 12 or higher. Models must not be dependent on a specific Intel Visual FORTRAN version to run. EMT models compiled in ~~7~~ or requiring GNU FORTRAN or Compaq Visual FORTRAN to run will not be accepted.

EMT models should not have dependencies on additional external commercial software, however dependencies on free, commonly available redistributable libraries (such as E-TRAN) may be acceptable.

Minimum format requirements from 15 July 2024

EMT models provided to AEMO and the NSP from 15 July 2024 must be compatible with PSCAD™/EMTDC™ version 5.0 and above and Intel FORTRAN Compiler Classic version 2021.x or higher. Models must not be dependent on a specific Intel Visual FORTRAN version or

Visual Studio version to run. EMT models compiled in or requiring GNU FORTRAN or Compaq Visual FORTRAN to run will not be accepted.

Also from 15 July 2024, EMT models that utilise any compiled or “blackboxed” code must meet the following criteria:

- Any compiled code must be provided as a DLL in both 32-bit and 64-bit formats.
- The model, including the DLL interface, must not contain or utilise any static library files (for example, .obj, .lib).
- The interface must be in the form of source code (such as .f, .f90-etc) and be compatible with both 32- and 64-bit compilers (separate interfaces for 32- and 64-bit isare also acceptable).
- The interface must use explicit linking.
- The interface (and DLL) must be compatible with the PSCAD snapshot function.

AEMO’s preferred approach for OEMs to achieve the above criteria is for DLLs to implement the Joint Working Group (JWG) B4.82/IEEE wrapper and provide an uncompiled (for example, .f, .f90-etc) JWG B4.82/IEEE compatible interface.

Implementing the JWG B4.82/IEEE interface is not mandatory, but highly recommended due to built-in functionality such as snapshot compatibility and efficient memory management between the simulation and DLL. In either case, the above criteria must be satisfied. It is up to the model developer to ensure other criteria listed in this document and specified by AEMO and NSPs are also met (for example requirements around output channels and simulation speed).

EMT models should not have dependencies on additional external commercial software, however dependencies on free, commonly available redistributable libraries (such as E-TRAN) may be acceptable.

AEMO will also accept DLLs that utilise redistributable libraries so long as the redistributable DLL file (for example, “msvcr100.dll”) can be included with the model and successfully run without having to install the entire redistributable package.

Custom code blocks and electrical blocks are acceptable provided that they are implemented as a PSCAD Fortran script segment or an uncompiled Fortran file with no references to static library files and are compatible with the PSCAD snapshot function.

4.4. Conventional EMT model requirements

Section 4.4 outlines the modelling requirements for conventional EMT studies that AEMO and the NSP may undertake outside of the *plant connection* process.

Models provided for these studies must comply with all EMT model requirements defined in Section 4.3, in addition the requirements below.

These requirements are not general requirements. They apply to relevant *plant* technologies only.

4.4.1. Black start model requirements

EMT models and simulations are required for adequately assessing the performance of *plant* and the *network* in black start scenarios. Models and Data Sheets for *plant* involved in *power*

system restoration must be consistent with the high-frequency transient model³⁵ requirements of the tables within Appendix C, and include additional elements as follows:

Generating systems and integrated resource systems or (Applicant provided):

- Major auxiliary loads including large fans and pumps greater than 1 MW each. The information provided should include the size and number of motors, their inertia, and operational reactances and time constants, and whether directly connected or interfaced via a variable speed drive.
 - Including details of the transformers that supply the auxiliary loads.
- Descriptions of any special abilities of the *plant* (e.g. for example, soft-start capable, TTHL bypass valves ~~etc.~~).
- A detailed description of any special control schemes active during system black (e.g. for example, changes to governor PID controllers while in isochronous mode).
- Surge arrester manufacturer, types, and V-I profiles.

Network (NSP provided):

- Geometrical representation of *transmission lines*, including conductor type and associated resistance, cable bundling configuration, transpositions (for lines above 5 km), tower types and spacing.
- *Transmission network transformers*, including saturation profile, air core reactance, winding configurations, number of limbs, all reactances and time constants.
- X and Y *transformer* differential protection relays, with on-site settings.
- Locations of synchronising breakers and synchrocheck relay settings.
- Details of under- or over-*voltage* protection schemes active in key *network* corridors.
- Surge arrester manufacturer, types, and V-I profiles.

Reactive support plant (NSP provided):

- Full representation of the reactive support *plant* and all *control systems*.
- Step-up *transformers*, including saturation profile, air core reactance, winding configurations, number of limbs, all reactances and time constants.
- All relevant X and Y protection relays with on-site settings.
- A detailed description of any special control schemes relevant during system restoration (e.g. for example, gain reduction for static VAR compensators [SVCs], ~~etc.~~).
- Surge arrester manufacturer, types, and V-I profiles.

Load (Applicant provided):

Large single load models are not required from Network Users, unless they propose to provide SRAS.

³⁵ These models must represent fast- and slow-front transients as defined by the IEC Standard 60071 Part 1.

4.4.2. Sub-synchronous model requirements

These studies are specialised and are not conducted routinely. If AEMO and the NSP determine that such studies are required to support secure system operation, adequate EMT models must be made available by the asset owners to facilitate the studies. Models provided for these studies must comply with all EMT model requirements defined in Section 5.4, in addition the requirements below.

Sub-synchronous resonance (SSR)

In addition to standard *generation* model components, owners of conventional synchronous generators may be required by AEMO and the relevant NSP to model the turbine-generator mechanical system as a lumped-mass model if it is determined that **sub-synchronous resonance (SSR)** studies are required for the *plant* under consideration.

The lumped-mass model consists of multiple masses representing different turbine shaft sections with each individual mass defined by its portion of mechanical torques, inertia constants, torsional stiffness between adjacent masses, and damping coefficient associated with each mass³⁶.

Models used for such studies can be confirmed through a combination of:

- Factory acceptance testing of the turbine-generator mechanical system.
- Using measured generator terminal quantities and performing a discrete or fast Fourier transform to confirm the frequencies of the torsional modes, which is then compared against the calculated torsional mode frequencies using inertial constants and stiffness. This applies to existing *synchronous generating systems* only.

Sub-synchronous control interaction (SSCI)/sub-synchronous torsional interaction (SSTI)

The level of detail required for these studies are provided under the “sub-synchronous interaction” entries of tables in Appendix C.

4.4.3. Format

EMT models for conventional EMT study purposes must be submitted in the format specified in Section 4.3.12.

4.5. Small-signal model requirements

Small-signal stability models are required for *plant* that contribute to local, intra-regional and inter-regional frequency modes in the *power system*. This **may include** synchronous generators and their **power oscillation dampers (PODs)**, dynamic reactive support plant with PODs, and any other *plant* which can reasonably impact damping of small-signal oscillations as determined by AEMO and the relevant NSP.

Small-signal stability models may also be required for studying the effects of sub-synchronous oscillations, such as inverter control system interactions up to —25 Hz. This will include any

³⁶ Information on damping coefficient is typically difficult to acquire, and is a function of the turbine-generator output. **The** information on inertia constants, torsional stiffness between adjacent masses and the portion of mechanical torque attributed to each mass must be provided.

plant which can potentially contribute to such oscillations as determined by AEMO and the relevant NSP.

For synchronous machines, a fully validated RMS transient stability model is generally sufficient for this analysis, provided that the corresponding small-signal model can be derived from block diagrams or source code using standard mathematical linearisation techniques.

For asynchronous technology, small-signal models derived from RMS transient stability models may be inadequate for the analysis of such phenomena. AEMO suggests that small-signal models represent all sub-synchronous frequencies.

4.4.1.4.5.1. Format

Small-signal stability models are submitted as part of the model package. The preferred approach is a Small Signal Analysis Toolbox (SSAT) model, however another format may be used (for example block diagrams suitable for linearisation). The format is to be determined through discussion between AEMO, NSPs, Registered Participants and OEMs.

SSAT is the currently nominated small-signal modelling tool. Models submitted in this format must be compatible with SSAT version 22 or greater.

~~Small signal stability models are constructed by AEMO or the NSP from the model block diagrams and model source code submitted as part of the model package. Where models cannot be readily linearised from the block diagram or source code based on the extent of information provided, additional information may be required from the Applicant.~~

4.6. Power quality model requirements

The following sets out the requirements for power quality models.

4.6.1. Harmonic Emissions

Harmonic current injection models used for harmonic frequency scans and harmonic distortion analysis in conventional *power system* harmonic analysis tools must provide:

- *Frequency-dependent Norton equivalences of each type of generating unit or bidirectional unit;*
- *Harmonic current injection profiles (for each harmonic order) at each generating unit or bidirectional unit, including:*
 - *Harmonic current magnitude, e.g. for example, in Amperes, or in percentage of fundamental current;*
 - *Harmonic current phase angle (only if the harmonic emission calculation method advised by the relevant NSP requires this information);*
- *Adequate model of collector grid³⁷; including for IBLs*

³⁷ Collector conductor models may need to consider skin and conductor proximity effects.

- ~~Generating unit or bidirectional unit~~ transformer models and ~~generating system or integrated resource system~~ transformer models³⁸; and

- ~~_____~~

- Data for harmonic filters (if present) ~~must be provided~~, including connection point(s) of the filters, filter layout (~~e.g. for example~~, single-tuned, double-tuned), quality factor and electrical parameters; and
- Where EMT-type models are used for harmonic analysis the requirements set out in Section 4.3.12 will apply³⁹.

The origin and methodology of the Norton equivalent sources must be documented and provided. Where harmonic current injections sources are provided in the form of harmonic current magnitude only, a method needs to be applied to summate the effects of the many individual harmonic sources in the *plant*.

A common method that has been used is the IEC Second Summation Law, as defined in IEC TR 61000.3.6-2012. From one of the findings documented in CIGRE Technical Brochure 672, “Power quality aspects of solar power”, the standard summation exponents are not suitable to be used. The Applicant should seek the NSP’s advice on the detailed methodology adopted by the NSP.

For photovoltaic *generation* using multiple inverters of the same manufacturer, harmonic currents should be added arithmetically independent of the harmonic order. Currently, no such finding has been published for wind *generation*, however, until different findings for wind *generation* are published, the same approach of applying arithmetically sum can be adopted for wind *generation*.

Format

Harmonic models must be provided in a format that is compatible with the harmonic analysis software platform nominated by the relevant NSP. This can be divided into types of simulation tools:

- Conventional harmonic simulation tools based on current injection techniques.
- EMT-type simulation tools where all requirements specified above will remain valid.

Depending on the specifics of the *connection point* and proximity to other sources of harmonics, both types of simulation models may be needed for a given *connection*.

4.6.2. Harmonic susceptibility and resonances

To account for the harmonic signature of *asynchronous plant* in harmonic susceptibility and resonance studies, it is necessary to include appropriate harmonic models of the harmonic generating devices, the harmonic impedance profile of the *network*, and the *frequency* dependent behaviour of the *network elements*. Where EMT harmonic susceptibility and

³⁸ Positive, negative and zero sequence impedance of these *transformer* models must be provided, including any earthing arrangement and *transformer* vector groups.

³⁹ This is not a general requirement and will be determined on a case-by-case basis and only when the conventional harmonic analysis techniques fail to achieve the required level of accuracy.

resonance studies are required, model components as outlined within Appendix C for harmonic studies must be included.

Format

Models used for harmonic susceptibility and resonant analysis must be provided as an EMT model complying with the format requirements of Section 4.3.12. The EMT model must comprise all control systems and switching components that contribute to the *plant's* harmonic profile. Further details of required components are provided in the “Harmonics” entries of the tables in Appendix C.

4.6.3. Flicker

The simulated ~~rms~~-RMS *voltage* magnitude/voltage waveform obtained from either RMS or EMT time-domain simulation can be fed into a flicker meter model following IEC 61000-4-15 for assessing the short-term and long-term flicker severity. These time-domain models are expected to include adequate representation of characteristics/functions/control systems involving/causing flicker.

Format

Models must comply with the RMS and EMT format requirements of Section 4.3.11 and Section 4.3.12.

4.6.4. Voltage unbalance

Models provided for harmonic studies are sufficient for *voltage* unbalance studies from a *generator* source perspective, however *network* elements that adequately represent *voltage* unbalance must also be included.

Models used to investigate this phenomenon must include the following:

- Steady state 50 Hz negative-sequence current injection, both magnitude and phase angle (phase angle is relative to the 50 Hz positive-sequence current phase angle), from the devices connected at the assessed bus must be modelled.
- *Transmission lines* must be modelled in the form that the information of 50 Hz negative-sequence impedance and the coupling impedance linking 50 Hz negative-sequence voltage and 50 Hz positive-sequence current are captured (for example, geometrical line representation).
- Negative-sequence impedances for synchronous machines and loads must be modelled.
- A variation of different power flow scenarios as well as other Steady State 50 Hz negative-sequence current injection devices must be modelled to capture the variations of the background network 50 Hz negative-sequence voltage contribution.

Additionally, known *voltage* unbalance susceptibility within the *plant* must be represented within the *voltage* unbalance model and provided within documentation.

Format

Models for voltage unbalance studies must be compatible with:

- The EMT model format requirements specified in Section 4.3.12; or

- A suitable power quality analysis tool as nominated by the relevant NSP.

4.7. Model aggregation

Traditionally there has been a one-to-one correspondence between *power system* elements such as *generating units* and the models of these elements in simulation software. Thus, each registered unit generating unit has been represented individually in the *power system* model. This is practical when the *power system plant* is a large *power station* comprising up to about a dozen individual large *generating units*.

However, contemporary *generating systems* or integrated resource systems such as wind and photovoltaic solar farms, ~~as well as other plant such as~~ grid-scale battery installations or hybrid systems, can include as many as several hundred *generating units* or bidirectional units. As these generating units-units (or many of them) are often usually identical to one another, representing them individually would multiply this has the effect of multiplying the required computational effort and simulation run time for little benefit, compared to representing ~~these~~ identical generating units-units as a smaller number of aggregates.

For ~~such generating~~ systems comprising ~~of~~ scores of small units generating units, the general rule is that the submitted *plant* model should contain no more than four units generating units of any one type. That is, units generating units should be combined into aggregates, with each aggregate representing multiple individual units generating units. In the simplest cases, a single aggregate may suffice to represent the totality of units generating units.

Aggregation should not be used to combine *power system* elements of differing types. These should retain separate explicit model representations, albeit some may be aggregates of identical units of that same type. An exception may be made where elements are similar in all material respects other than size (for example a 3.0 MW and a 3.2 MW wind turbine with the same underlying technology and control systems) and where evidence is provided of this similarity by way of manufacturer documentation, to the satisfaction of the NSP and AEMO.

A similar aggregation principle can be applied to large IBLs consisting of small, identical modular components, such as a hydrogen production facilities with multiple electrolyser clusters.

Where the NSP and AEMO requires a single load facility to be represented by a composite load model, the CMLDxx model family offered by PSS@E can be used, and parameterized based on the configuration of the load facility. Subject to AEMO and NSP's agreement, other forms of composite load model can be also used, where tThe largest DOL induction motor within a single load facility should be modelled explicitly, and ofor loads where a model is assessed to be required. Other smaller motors can be modelled as lumped motors, provided the size of any lumped motor is smaller than the large induction motor on site..

4.7.1. Scaling principles for derivation of multiple-unit aggregates

The following general principles are assumed as the default for producing aggregates of N identical generating units or bidirectional units units, where each unit is assumed to consist of a 'plant' at low voltage (LV) in cascade with a unit *transformer* stepping up to medium voltage (MV).

The MV 'collector system' which connects the individual units together is treated separately in Section 4.7.2.

Where the modelling of *power system plant* requires an aggregation method that varies from these principles, this must be clearly documented in the RUG. Alternative aggregation methods include the provision of a separate aggregate model not directly derived from the individual unit model. Evidence must be submitted to AEMO and the relevant NSP for the suitability of the aggregation method relative to the simple application of the scaling principles below. AEMO and the NSP must jointly assess this evidence, and may accept the different method, or determine that the scaling principles will apply if the evidence submitted is weak.

- The aggregate unitgenerating-unit is represented in the model in an analogous fashion (size aside) to a single unitgenerating-unit. It has the same associated dynamic model and appears similar to a single unit generating-unit in the *network* model in cascade with an equivalent unit *transformer*.
- The LV and MV voltage levels are the same for the aggregate as for the individual unitsgenerating-units.
- The MVA rating of the aggregate *plant* is N times the MVA rating for an individual unitgenerating-unit. (This rating is called MBASE in the PSS®E software.)
- The *active power* and *reactive power* of the aggregate are the sums of the individual unitgenerating-unit powers. For modelling purposes, there is an underlying methodological assumption that each unit generating-unit has identical power outputs, although these will vary from unit to unit.
- Any other 'size quantities' specified in SI units, or in per-unit on a fixed system MVA base, are multiplied by N in the aggregate. Examples of size quantities are rated current in Amperes, rated torque in Newton-metres, and inertia constant in Joules or VA-seconds (but *not* speed or voltage). Where, on the other hand, the model specifies these quantities in a per-unit system on the unit generating-unit MVA base, their numerical values are identical.
- The MVA rating of the aggregate unit generating-unit *transformer* is N times the MVA rating of each unit generating-unit *transformer*.
- Any internal series impedances of the aggregate unitgenerating-unit, unit generating-unit *transformer* and any intervening LV cables, when specified in ohms or in per-unit on a fixed system MVA base, have values 1/N times their values for each corresponding unitgenerating-unit. Where, on the other hand, the model specifies these quantities in per-unit on the unit MVA base, their numerical values are identical.
- Any internal shunt admittances of the aggregate unitgenerating-unit, unit generating-unit *transformer* and LV cables, when specified in sSiemens or in per-unit on a fixed system MVA base, have values N times their values for each corresponding unitgenerating-unit. Where, on the other hand, the model specifies these quantities in per-unit on the unit MVA base, their numerical values are identical.

Implicit in these scaling principles is a requirement that the underlying model of the unit is also capable of representing the aggregate of N units when configured with the larger MVA rating. If appropriate, the model may be coded to indicate the level of aggregation explicitly in the model configuration (for example, by including either each unit size or the number N of identical units as a configuration parameter). However, any necessary change to model configuration or settings beyond those stated above when switching between an individual unit and aggregate representation, or between aggregate representations with different numbers of units, must be clearly documented in the RUG.

4.7.2. Representation of collector systems in aggregated models

Special attention must be given to the aggregated representation of the MV ‘collector system’ that connects the MV terminals of the *generating unit or production unit transformers* and (usually) conveys the aggregate *generated* or consumed power to an MV *collector bus* at the relevant substation.

In the simplest case, all identical ~~units~~*generating units* are combined into a single aggregate, and the model specifies a single equivalent collector impedance connected between the MV collector bus and the MV terminal of the aggregate equivalent ~~generating unit~~*transformer*. In this case, the recommended procedure for calculating the equivalent collector impedance is given in National Renewable Energy Laboratory (NREL) report NREL/CP-500-42886, “Method of Equivalencing for a Large Wind Power Plant with Multiple Turbine Representation”⁴⁰. This procedure is based on calculating the equivalent series resistance and reactance that yield the same *active power* and *reactive power* consumption as the original MV collector system, where the units in that system are assumed for simplicity to all operate at identical *voltage*.

The same procedure must be applied when the system is divisible into up to four component subsystems, each with its own independent *connection* to an MV collector bus. In this case, each subsystem furnishes its own aggregate with the equivalent collector impedance calculated as above.

The Applicant may propose an alternative aggregation method to the NSP and AEMO, who will jointly assess it. An alternative method is required in any case where the *plant* layout does not readily fit in either of the two categories above. As a matter of principle, it is noted that there is no one correct way to aggregate any collector system, and different principles such as equalising losses (as per Muljadi et al), or reproducing an equivalent MV *voltage* diversity, will yield different results. All aggregation methods implicitly induce a degree of modelling error which must be acknowledged whenever comparisons are undertaken between modelled and true *plant* behaviour.

4.7.3. General considerations

For a *generating system or integrated resource system* with many *generating units or bidirectional units*, provision of the required aggregate model will be the primary method considered for wider *power system* studies and for AEMO’s own assessment tools.

Aggregate models should continue to provide access to the LV terminal bus quantities for each aggregate equivalent ~~unit~~*generating unit*, including *active power*, *reactive power* and *voltage* magnitude. This includes EMT models that have been black-boxed. Figure 2 shows a high-level example of how an EMT model that has been aggregated and black-boxed can provide access to terminal quantities.

⁴⁰ Muljadi et al, 2008.

Figure 2 Aggregated and black-boxed EMT model high level representation

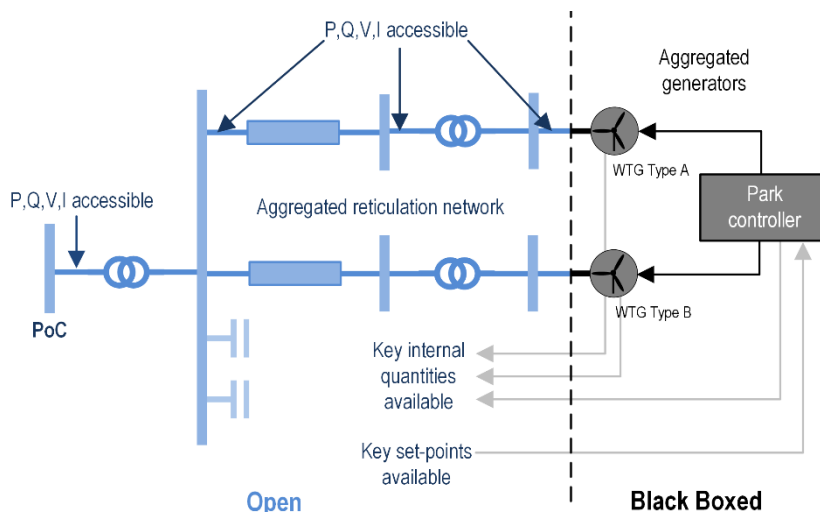

For model validation purposes, the aggregated unit generating unit and aggregated generating system responses must conform to the accuracy requirements in Section 6.2, where the individual aggregated unit generating unit model terminal quantities have a slightly moderated accuracy tolerance compared to the model *connection point* quantities. The procedure for R2 validation will involve collecting field measurements both for the aggregate generating system and for one representative unit generating unit for validation.

High voltage *plant* connecting directly to the *transmission network* is to be explicitly modelled.

1.5.4.8. Model and plant updates

While each submitted model must be a faithful representation of the *plant* at the time of submission, it is natural to expect that updates to the model will be issued from time to time by the supplier or other party responsible for the model.

It is especially important that alterations to the *plant* or its control firmware that alter the *plant's* dynamic performance are correctly reflected in an updated simulation model. It is also possible for several reasons for model updates to be proposed without any change to the *plant*.

4.8.1. Updates to account for simulation model improvements

The reasons for model updates relating to simulation improvements include the following:

- **Updates** to improve computational or numerical performance of the model code;:-
- **Updates** to incorporate additional functionality provided with newer versions of the same equipment, or to allow greater flexibility in configuration;:-
- **Updates** to broaden the scope of the model code to represent multiple equipment types within the one family, by varying the configuration parameters;:- or
- **Updates** to correct 'bugs' or unanticipated performance issues, particularly to reflect novel 'use cases' arising during long term operation.

In general, an update to a model held by AEMO and the NSP for specific *power system plant*, in the absence of any alteration to the *plant* itself, will be considered only where it is relevant to

the performance of that element in ongoing dynamic assessments (including the performance of the simulation software itself). Where the update is relevant only to accommodating future *plant* using the same model, it is generally expected that the existing *plant* will continue to use the 'old' model, which will continue to perform adequately after new *plant* ~~is are~~ introduced using the updated model version.

The updated model's acceptance by AEMO and the relevant NSP will be subject to additional dynamic model acceptance testing conducted by AEMO or the NSP at the Applicant's expense.

4.8.2. Updates to account for changes in the plant including parameter changes

Updates to *plant* firmware or settings that alters dynamic performance or protection operation must be captured in a revised dynamic model(s) to be submitted to AEMO and the NSP. The revised dynamic model(s) must be accompanied by a report that shows the revised model(s) and its settings meets all accuracy requirements to 'R1'⁴¹ level, prior to acceptance of *performance standards* for the altered *plant*⁴². This will be followed by on-system tests as part of *plant* commissioning, including tests to validate the revised dynamic model(s) to R2 level.

The updated model's acceptance by AEMO and the NSP will be subject to additional dynamic model acceptance testing conducted by AEMO or the NSP at the Applicant's expense.

4.8.3. Updates to account for later versions of simulation tools

Occasionally⁴³, it may be necessary for AEMO and the NSP to move to later versions of RMS and EMT simulation tools. Ideally, later versions of these simulation tools will be backwards-compatible with existing models, or where AEMO has the source code for RMS models, AEMO will independently recompile the model and update model libraries.

However, if AEMO or the NSP deem it necessary that a later version of a simulation tool is required to undertake studies, and an Applicant's existing model no longer functions correctly in the later version of the simulation tool, an update to the Applicant's model is required to provide compatibility with the later version of simulation tool. This model update is required from the Applicant without cost to AEMO or the NSP. These updates may be required at any point in the life of the *plant*.

4.8.4. Updates to account for additions to otherwise unaltered legacy plant behind a connection point

During the lifetime of a *generating system, integrated resource system, or customer installation established under superseded modelling requirements, augmentations may be undertaken that have the effect of adding equipment behind the existing connection point but otherwise leaving the established plant unaltered. In these cases:*

⁴¹ 'R1' refers to pre-connection in the sense that it is used in [NER clause S5.5.6 of the NER](#).

⁴² See [NER clause 5.3.10 of the NER](#) for *Generators and Integrated Resource Providers*. -NSPs have a general obligation to ensure that modelling data used for planning, design and operational purposes is complete and accurate at all times and provide it to AEMO and other NSPs if reasonably required to model the static and *dynamic performance* of the power system (see [NER clause 5.2.3\(d\)\(8\) & \(9\)](#)). -MNSPs and *Customers* cannot connect altered equipment until an *application to connect* is made and a *connection agreement* is entered into (see [NER clause 5.2.3\(g\)](#) and [5.2.4\(b\)](#), respectively).

⁴³ For example, ~~since-between~~ 2009 ~~and 2023~~, AEMO has needed to change PSS@E versions twice: v29 to v32, and v32 to v34 (~~currently co-supported~~), and PSCAD™ versions ~~enacted~~ twice: v4.2 to v4.6 ~~and v4.6 to v5.0~~.

- models for the new *plant* must be provided in accordance with these Guidelines, representing good industry practice;
- to the extent that the *legacy plant* and the new *plant* are likely to interact in a manner that materially impacts *power system* stability or security, models for the *legacy plant* must be provided in accordance with these Guidelines to the extent reasonably practicable; and
- the Applicant may apply for an alternative process for the provision of updated models for *legacy plant*, to be considered by AEMO in accordance with Sections 8.3. and 8.4, and considering the principle that the model requirements should not present an unnecessary deterrent to augmentation works that are likely to benefit the *power system*.

From a technical-modelling perspective, industry experience suggests it is likely that material interactions between *legacy* and new *plant* in the *power system* are most likely to arise from one of the following four components:

- Outer control loops for voltage and/or reactive power within a *plant*.
- Inner control loops driving unit-level voltage and current, including fault ride-through modes and PLL dynamics for electronic equipment.
- Outer control loops for *dispatch* and regulation of active power production or consumption by the *plant*.
- Outer control loops for *frequency* response and control.

The Applicant is encouraged to utilise all relevant information available to develop the *legacy plant* model. Generic models can be used to represent *legacy plant* when, despite its best efforts, the Applicant cannot obtain detailed site-specific models. The generic model should include all information related to the components listed above. Where practical, components which can be validated as per the R2 validation process must be included in *legacy plant* generic models. Other components of the generic model, which cannot be validated during the R2 validation process, can be validated by the Applicant through the ongoing compliance monitoring scheme. The validated model must be provided to AEMO and the NSP within a time frame agreed with them.

If the Applicant can obtain a vendor-specific model, for the exact or similar type of equipment installed the *legacy plant*, the vendor-specific model should be used to model the *legacy plant*. The site-specific model parameters should be used wherever available. In the absence of such site-specific model parameters, the Applicant must provide a set of model parameters which are configured based on relevant information available to the Applicant in respect of the *legacy plant*, including:

- previous commissioning results and operational records;
- technical documentation of the devices installed at the *plant*, and
- any other relevant information which the Applicant can reasonably obtain.

The model parameters should be configured so that the *legacy plant* model can demonstrate similar simulated response as observed in the commissioning or operational records. The model parameter configuration should aim to achieve the accuracy requirements specified in Section 6.2.1 of these Guidelines, with good engineering judgement applied to identify a “close enough” parameterisation outcome to achieve an optimal level of accuracy considering all information available for the model parameterisation.

The parameterisation associated with the model performance that can be validated in the R2 commissioning stage should be prioritised. The vendor-specific model must provide access to model parameters through which the model response can be adjusted. An unadjustable model with poor correlation with the historical *plant* performance is likely to be inadequate. The NSP and AEMO may require the legacy *plant* model to be validated by the Applicant through the ongoing compliance monitoring scheme, or through tests conducted under NER 5.7.6.

Consideration will also be given to the availability within the NEM of models for similar equipment which might be adapted to the legacy *plant* through similar parameter reconfiguration.

5. Model documentation

Information required for the modelling of *power system plant* for all applicable studies including load flow and fault level studies, specialised studies, black-start studies, power quality analysis, connection assessments, stability assessments and *system strength impact assessments* is required in a number of forms. For example:

- The RUG, required under ~~clause-NER~~ S5.2.4(b)(8) ~~of the NER~~, for both RMS and EMT models⁴⁴;
- Completed Data Sheets, required under ~~clause-NER~~ S5.2.4(a);
- Functional block diagram information for RMS models, required under ~~clause-NER~~ S5.2.4(b)(5); and
- Model source code information for RMS models, required under ~~clause-NER~~ S5.2.4(b)(6).

This model information must be consistent. For example:

- The specific parameters relevant to a dynamic model required in tabular form by the Data Sheets, must be found in the functional block diagrams, also required by the Data Sheets⁴⁵;
- The functional block diagrams for RMS models required by the Data Sheets, must match the functional block diagrams provided under ~~clause-NER~~ S5.2.4(b)(5); and
- The functional block diagrams for RMS models provided under ~~clause-NER~~ S5.2.4(b)(5) must match model source code information provided under ~~clause-NER~~ S5.2.4(b)(6).

5.1. Releasable user guide

The RUG accompanies a model to describe how it is to be used and includes other information such as *transformer* modelling information, operational information, information on *protection systems* or *control systems* that are relevant to the assessment of proposed *performance standards*, and *connection point* information. This information in a consolidated form is required to facilitate the *connection* and other studies and to avoid misinterpretation and potential errors.

⁴⁴ Where the requirement to provide a RUG arises by virtue of the application of ~~NER clause~~ S5.5.7(b1)(1)(i), the requirement applies to all *generation*, not just *generation* with a nameplate rating of ≥ 30 MW.

⁴⁵ The identical numerical value may not match between the parameter requested in the table and the functional block diagram due to differences in units, or a requirement to provide parameter information in a functional block diagram in 'per unit' form, however, it is expected that the parameter is recognisable in the functional block diagram.

The RUG is routinely sent to *Registered Participants* as required by the NER, and as such, should not contain any information that is considered confidential. The RUG must be written such that a *Registered Participant*, without any prior knowledge of the *plant*, would be able to successfully perform studies.

RUGs should comply with the template set out in the Guideline for Preparation of a Releasable User Guide⁴⁶.

5.2. RMS and EMT model documentation

Supporting documentation included in the RUG must be relevant to the site-specific model and must contain sufficient information for AEMO and the NSP to use the RMS and EMT models to carry out due diligence and *power system* studies.

The information in the supporting model documentation includes:

- Information that is necessary to allow modelling of the *plant* (in the case of *generation*, both each *generating unit* and *generating system*) for *connection* assessment and other *power system* studies;
- Instructions on the use and operation of the RMS and EMT models, including operational limitations;
- ~~include-De~~descriptions and setting values for control sequences (~~e.g.for example,~~ fault ride-through control schemes and any other relevant *control systems*) that are relevant to the intended use of the model;
- Descriptions, site-specific values and ranges of all configuration parameters, component trip/status codes used in the RMS and EMT models; and
- Descriptions, site-specific values and ranges of all user-adjustable variables and *control system* settings contained within the model.

5.2.1. Additional information required for fault level calculations

Additionally, *plant* using ~~converter-converter~~-connected technologies must:

- State within the RUG timeframes ~~within~~-which short circuit related parameters of the supplied model are appropriate; and
- Provide information on the magnitudes and phase angles of the phase-current *connection point* contributions that their equipment is expected to make (as a function of *connection point voltage-dip* magnitude and duration) for the following types of voltage dips:
 - In only one phase;
 - Equal dips in two phases and none in the third; and
 - Equal dips in three phases.

⁴⁶ Available at: http://www.aemo.com.au/-/media/Files/Electricity/NEM/Network_Connections/Transmission-and-Distribution/Guideline-and-Template-for-preparation-of-a-Releasable-User-Guide

5.2.2. RMS model block diagrams

Block diagrams must be submitted alongside all RMS models. Several attributes will be assessed, with requirements set out below:

- The transfer function block diagram must include all functional controllers and *plant* that materially affects the performance of the model⁴⁷.
 - The models of the controllers and items of *plant* must be easily identifiable.
 - All individual blocks should be expressed explicitly. The use of black-box type approach for representing any of the individual transfer function blocks is not acceptable.
 - The interconnection of the different functional controllers and the items of *plant* must be clearly shown.
- Images and tables embedded in documents must be of sufficient resolution to easily identify all components, parameters and values.
- The transfer function block diagram must be described by Laplacian (preferred) or Z-domain transfer functions.
- The transfer function blocks and model parameters must be recognisable in terms of the physical design of the *plant* and *control system* settings, to allow the NSP or AEMO to assess *control system* settings proposed by the Applicant, or design new settings.
- The transfer function blocks and model parameters must include any relevant non-~~linearities~~, such as limits, arithmetic or mathematical functions, deadbands or saturation, ~~etc.~~ Any limits must be shown as windup or non-windup limits. Non-windup limits must show how the non-windup nature of the limit is achieved (e.g. for example, which model state variable is being limited and the relationship between the limit value and the state variable that is being affected by that limit).
- The model parameter values must reflect typical values appropriate for the actual equipment installed. All model parameters and their values must be shown either directly in the transfer function block diagram or in a tabular format.
- *Control systems* with several discrete states or logic elements may be provided in flowchart format if a block diagram format is not suitable.
- Parameter values that are intended to be (or can be) externally adjusted (e.g. for example, those explicitly in PSS®E dynamic data file, VARs, CONs, ICONs ~~etc.~~) must be clearly identified in the model block diagram.
- The model block diagram and flowcharts (if applicable) must represent the corresponding model source code⁴⁸.
- The model inputs and outputs shown in the transfer function block diagram representation should match those indicated in the Data Sheets.

⁴⁷ Included in this category are the central park level controllers that schedule active and reactive power across wind and photovoltaic solar farms.

⁴⁸ It is also expected that the functional block diagrams provided with the Power System Design Data Sheet and Power System Setting Data Sheet Data Sheets for a generating system or integrated resource system will match these diagrams, although the parameter values might differ to reflect *connection point* performance requirements.

- The state variables shown in the transfer function block diagram representation should match those indicated in the Data Sheets.
- Model documentation and transfer function block diagram representation should be provided at the level of detail required for AEMO and NSPs to derive the corresponding linear small-signal model of the equipment.
- Dynamic data must be provided as 'per unit' quantities on the machine MVA base⁴⁹.

5.3. Small-signal stability model documentation

~~Supporting documentation for small-signal stability models will depend on the format of the submitted model as set out in Section 4.5. Content of small-signal stability model documentation including benchmarking requirements should be developed through discussion with AEMO, NSPs, Registered Participants and OEMs as developed by AEMO and the NSP from the model block diagrams (see Section 4.5). Generally, if the Applicant follows the requirements in Section 5.2.2 when developing model block diagrams, this process should yield sufficient information for small signal model to be successfully constructed and used by AEMO and the NSP.~~

~~Where the block diagrams are unclear, or where a linearised model has been provided by the Applicant directly, AEMO and the NSP require documentation that is sufficient to understand all components of the model and to perform small-signal stability studies to their satisfaction.~~

5.4. Harmonic model documentation

Harmonic model documentation must be sufficient for the relevant NSP to understand and use the harmonic model in the software package of their choice. Where the harmonic model provided is an EMT model, the principles set out in Section 5.2 should be adhered to when developing documentation, with specific differences between the harmonic and transient stability EMT model highlighted.

Additionally, documentation for the harmonic model must include any or all of the following as agreed with the relevant NSP and AEMO on a case-by-case basis:

- Harmonic emission studies:
 - A harmonic profile at different loading levels, between 0 to 100%, in 10% steps if it is demonstrated the harmonic current profile varies linearly as function of the loading;
 - A suitable frequency-dependent Norton equivalent for the harmonic injecting device to clearly demonstrate how the current injected and the equivalent impedance vary as function of harmonic order; and/or
 - Documents describing the suitability of the EMT-type model submitted consistent the level of modelling discussed in Appendix C.
- Harmonic susceptibility studies:

⁴⁹ If another base is more practical, such as the turbine-governor quantities based on the turbine MW rating, this may be acceptable as long as it is clearly identified as such in the model and documentation.

- Documents describing the suitability of the EMT-type model submitted consistent the level of modelling discussed in Appendix C.

6. Model accuracy requirements

This Section 7 specifies model accuracy requirements. These model accuracy requirements:

- Are applicable regardless of the type of model provided; ~~and~~
- Will apply regardless of the type of *generating system*, integrated resource systems, network or other ~~and plant, and-~~
- Will apply to detailed IBL models other than IEEE ZIP and Composite load models (NSP advice should be sought for the latter in terms of necessary load commissioning requirements).

6.1. Accuracy locations

Model accuracy must be demonstrated for all components within a *plant* that impacts on power system dynamic performance.

Synchronous plant typically requires demonstration of model accuracy at each unit terminal ~~generating units' terminals~~.

Power electronic interfaced *asynchronous* technologies (such as wind and photovoltaic solar *generating systems*) may consist of several *generating* units or bidirectional units, *plant* controllers, Reticulation Networks and dynamic reactive support devices such as STATCOMs and *synchronous condensers*. As such, demonstration of model accuracy must occur at:

- Connection point or high voltage terminals of plant transformers.
- Reticulation Network collector bus to which an individual item of dynamic *plant* is connected.
- *Generating* or bidirectional *units* (for each different type of unit generating unit, including batteries).
- Terminals of each type of dynamic reactive support device, such as STATCOMs and *synchronous condensers* (if applicable).
- Central park-level controllers, and any other overarching coordinated controllers.

For a Network User's facility solely consisting of IBL, demonstration of model accuracy must occur at the connection point or high voltage terminal of the main supply transformer. For a Network User's facility consisting of both IBL and non-IBL components, demonstration of model accuracy may occur at the buses where IBL model aggregation is considered. Demonstration of model accuracy may be conducted at other locations within the Network User's facility, subject to agreement between the NSP and the Applicant.

6.2. Model performance measures

The performance measures described in Section 6.2 must be used to determine the model accuracy, where all accuracy bands are to be referenced to the model's response. A table specifying quantities to which these requirements apply is provided in Appendix D.

General considerations are:

- The term “transient window” is used to describe the moment a reference change or Disturbance commences until the response returns to within $\pm 5\%$ of the model’s maximum induced or reference quantity change. Appendix E provides a visual representation of this definition.
- Accuracy of EMT model responses are evaluated on their simulation-tool calculated RMS quantities⁵⁰, with filtering appropriate for a 50 Hz nominal system. Larger filtering time constants on measurements will require justification.

6.2.1. Accuracy criteria

The following criteria apply, and no criterion should override another, except where noted:

- (a) For *synchronous plant control system* models, the overall linear response over a frequency bandwidth of at least 0.1–5 Hz must be within the following tolerances:
 - (i) Magnitude must be within 10% of the actual *control system* magnitude at any frequency; and
 - (ii) Phase must be within 5 degrees of the actual *control system* phase at any frequency.
- (b) For time domain responses that include non-linear responses or performance, as well as responses to switching or controlled sequence events (~~e.g. for example~~, operation of fault ride-through schemes and converter mode changes), the key features of the response are within the following tolerances:
 - (i) Rapid slopes in the actual *plant* response, compared with the simulated response must be within the less restrictive of:
 - (A) $\pm 10\%$ of the change for 95% of the samples within the transient window; and
 - (B) From the start to the finish of the slope, a difference of less than 20 ms.
 - (ii) For rapid events caused by control sequences (such as some fault ride-through control schemes) or switching events, the sizes of peaks and troughs (measured over the total change for that peak or trough) must be within 10% of the change for 95% of the samples within the transient window;
 - (iii) Oscillations in the actual response of the *plant* for *active power*, *reactive power* and *voltage* in the *frequency* range 0.1 to 5 Hz⁵¹ must have damping⁵² and *frequency* of the oscillation within 10% of the simulated response for 95% of the samples within the transient window. ~~The phase angle between different quantities (e.g. active power versus reactive power) at the oscillation frequency must be within 5 degrees.~~ This does not apply to rapid events under paragraph (b), but applies to any subsequent oscillations;

⁵⁰ Per-phase RMS quantities for unbalanced Disturbances

⁵¹ ~~The upper limit of the requirement may be increased to 25 Hz, for quantities obtained at the connection points of inverter based resources.~~

⁵² Measured as a rate of decay of the oscillation – ~~e.g. for example~~, halving time.

- (iv) The timing of the occurrence of the rapid slopes, events or the commencement of oscillations described in paragraphs (a)-(c) must be consistent with the *plant* characteristic that initiates the response⁵³.
- (c) Taking into account the *voltage* at the *connection point*, at any point during the simulation, the deviation of the actual measured responses from the simulated response for *active power* and *reactive power* must not exceed 10% of the total change in that quantity for 95% of the samples within the transient window. During periods of oscillatory behaviour, this criterion applies to:
 - (i) The first cycle of the oscillatory response after the transient period (~~i.e. that is~~, if associated with a fault, then after clearance of the fault and the transient recovery from the fault); and
 - (ii) After the first cycle of the oscillatory response, to the upper and lower bounds of the envelope of the oscillatory response.
- (d) Taking into account the level at which *voltage* settles at the *connection point*, the final *active power* or *reactive power* value at which the *plant* would settle is within the more restrictive of:
 - (i) The final value at which the model response settles $\pm 2\%$ of the plant's maximum capacity; or
 - (ii) The final value at which the model response settles $\pm 10\%$ of the total change in the quantity following the Disturbance.

Where measurement results can be shown to have been affected by changes in supply source (~~e.g. for example~~, the wind strength for a wind turbine), this shall be taken into consideration when assessing this criterion, so long as sufficient evidence can be shown to demonstrate the cause of the input power change, and in the case of large variations, sufficient efforts were made to re-test the plant to obtain improved measurement results.

Note that for all *plant* closed-loop internal quantities and *production generating unit* terminal quantities **for aggregated models only**, replace all instances of "95%" in Section 6.2.1 (referring to samples within a transient window) with "90%". *Connection point* quantities do not have this accuracy moderation applied.

If AEMO and the NSP agree that dynamic changes in the *network* or prime mover have contributed to model inaccuracy, they may relax one or more of these accuracy requirements. Additionally, further deviations beyond the model accuracy requirements for *plant* internal quantities may be permitted when direct measurement of internal quantities is not practicable or there are known model deficiencies⁵⁴.

The accuracy criteria listed above do not apply to IEEE ZIP models or composite load models, if the use of such models to represent large single loads has been agreed by AEMO and the NSP. For more detailed IBL models, the accuracy criteria in (c) and (d) listed above will apply.

⁵³ This is a difficult criterion to specify, as it depends on what initiates the event or oscillation. Switching events or rapid control actions initiated as a result of passing a threshold level in a measured quantity and any time delays in the design of the *plant* should be straightforward to assess. It is recommended that the fallback criterion for this requirement be that:

- (i) the response must be explainable; and
- (ii) any inconsistency in the response should lead to an investigation to establish a plausible reason for the inconsistency. A revision to the model should be considered in the latter circumstance.

⁵⁴ For example, *synchronous generation* field current.

The accuracy criteria in (a) are only applicable to the synchronous plant components within any single large load. The application of the accuracy criteria in (b) are subject to whether the IBL needs to demonstrate compliance with relevant ride through capability performance standards.

6.2.2. Balanced and unbalanced Disturbances

Positive-sequence simulation models are expected to meet the model accuracy requirements specified in Section 6.2.1 for balanced Disturbances. For comparison of the response to different types of unbalanced faults, a positive-sequence model can still be used if it can achieve the required accuracy requirements⁵⁵.

When a positive-sequence model fails to meet the accuracy requirements by a material margin, the use of EMT-type or three-phase RMS simulation models is permissible provided that the simulation model chosen can demonstrate compliance with the model accuracy requirements.

6.2.3. Stable response for the entire intended operating range

The model initialisation and operating range should be consistent with the actual equipment design in regard to the following:

- The entire range of *active power*.
- The entire range of *reactive power/power factor* (including limits of *reactive power* generation and consumption).

6.2.4. Stable but different response when the response becomes limited

Models must demonstrate accurate and stable behaviour when the limits implemented within the *plant control systems* are reached. For example, activation of a *synchronous plant* under- or over-excitation limiter should not cause model instability, or produce the same response for a scenario where limiters have not been activated. Output of each limiter must be available for plotting to demonstrate that it acts for intended operating conditions, and do not falsely activate when the limit is not reached.

6.2.5. Unstable response when operated beyond its intended operating range

Where *network* conditions, energy source limitations, Disturbances ~~eteor other factors~~ would cause the *plant* to become unstable, activate protection mechanisms, or otherwise cease operation, it is expected that the model would reflect the *plant's* response. Models should not be created such that they continue to operate stably outside of the *plant's* operating envelope⁵⁶.

6.2.6. No unexpected or uncharacteristic responses

The model must not show characteristics that are not present in the *plant* response, both in terms of the electrical response and modelling numerical artefacts.

⁵⁵ When using positive-sequence type models for simulation of unbalanced Disturbances, the Applicant must provide information on any possible changes in the model parameters to simulate various types of faults.

⁵⁶ Models that cease output when exposed to conditions outside the intended operating range are not considered inferior, however, the cessation of the model output must not result in instability or crashing of the underlying simulation tool.

6.3. Model validation and confirmation

Each model must be developed and tested to the extent reasonably necessary to establish that it will meet the accuracy requirements. To achieve this:

- During the *plant* design and development stages, it is expected that the model will be rigorously derived from design information and its performance is confirmed against the actual *plant* response; and
- R2 parameters and models must be derived from on-site tests.

Parameters, other than R2, that contribute most significantly to the accuracy of the model for fault, *voltage* and *frequency* Disturbances in the *power system*, must be derived from on-site tests, where possible. Test results from the commissioning tests (used to confirm compliance of the *plant* with *performance standards*) may also provide, or contribute to, R2 data values⁵⁷. These parameters must still be validated (in aggregate) through the validation of the overall performance of the *plant*, *network element*, device, unit or controller to which they pertain.

6.3.1. Model confirmation for plant with limited impact

Where the new or altered *plant* is expected to have limited foreseeable impact on the surrounding *network* and nearby *plant*, model validation requirements may be relaxed by AEMO and the NSP. This could apply to either the scope of model validation tests or the permissible model accuracy requirements.

Confirmation of model performance would consist of the following (to be provided to the NSP and AEMO):

- Factory test results for:
 - ~~— *Generating unit or bidirectional unit and energy conversion plant;*~~
 - *Control systems*, including the energy conversion *plant* and electricity output control and regulation *plant* (~~e.g. for example,~~ exciter, AVR and PSS);
 - ~~*Generating unit Unit transformer, and*~~
 - ~~– The *generating systems system* transformer (if different from the *unit generating unit transformers*); and-~~
 - ~~*Load converter interface, including UPS devices, rectification devices, (such as hydrogen electrolysers), and relevant control systems.*~~
- Comparisons of simulations for step response tests against the on-site step response test results. This would include tests at several load levels and operation across the relative power range, such that:
 - The model response is within the tolerances specified in these Guidelines or tolerances agreed by AEMO and the NSP on a case-by-case basis; and

⁵⁷ Note that ~~NER clause S5.2.4(d)(1) of the NER~~ specifies that the R2 values must be submitted to AEMO and the NSP within three months of the completion of commissioning.

- Deviations must be reasonably explained and attributed, for example, to the influences of external parameters or differences in pre-test simulation conditions with actual system conditions.

6.3.2. Pre-connection model confirmation

AEMO requires OEM confirmation of the response of their *plant* by factory or laboratory testing where:

- *Connections* are proposed to parts of the *network* with low system strength where the standard *plant* might not be adequate any more;
- When the *plant* is designed to provide functionality not offered previously; -or
- When new *plant* is introduced to the *NEM* with unexpected or inferior modelling responses.

Confirmation of RMS- and EMT-type model adequacy prior to detailed *connection* studies is prudent to minimise risks that may multiply the time and effort in assessing a specific *plant connection* and alterations.

The following principles will apply to pre-*connection* model confirmation tests:

- Among Disturbances applied for model confirmation tests, there should be a two-phase-ground or three-phase fault equivalent to what might be experienced by a *generating unit* or *bidirectional unit* upon installation. The same should be applied to IBLs which are expected to be compliant with relevant ride through capability performance standards.
- The post-fault fault level and *network* impedances used for the testing should be reasonably representative of, or lower than, the post-fault fault level that the *plant* would experience.
- The individual item of *plant* tested is identical to the ones to be installed.
- The *plant* tested has identical *control system* settings to the one being installed, or the difference in settings can be translated into appropriate model parameter values applicable to the *plant* to be installed.
- The accuracy and adequacy of EMT-type models must be confirmed against the response of individual items of *plant*, including *generating units*, *bidirectional units* and dynamic *reactive power support plant* (if applicable), and IBLs for the conditions specified above, or against the validated EMT-type models.
- Changes in the *control systems* or settings of individual items of *plant* are necessary if the submitted EMT-type model exhibits uncharacteristic or unexpected responses.
- Model response should be generally aligned with expected response. The model accuracy requirements set out in Section 6.2.1 will not strictly apply during this stage.
- Where both RMS and EMT models are provided, responses of the two models should be benchmarked against one another in accordance with the Dynamic Model Acceptance Guideline. While the accuracy requirements in Section 6.2.1 will not apply in the absence of actual *plant* response data, the criteria in this section may be applied as guidance for assessing benchmarking performance with the EMT model response in place of the 'plant' response and the RMS as the 'model' response. Divergences in model responses from the strict criteria should be expected, especially on sub-cycle time scales following the application of a large Disturbance. For small Disturbance response, such as a *control system* reference step change, both RMS and EMT should provide reasonably close

responses (<10% discrepancy) in terms of rise time, overshoot, and settling time, and should achieve the same steady-state value following the same reference step change. If this accuracy cannot be achieved, the Applicant must provide reasons to the connecting NSP and AEMO.

- Tests should be conducted across a range of operating conditions including pre-Disturbance active power and reactive power levels.

NSPs must provide the range of operating conditions, including pre-Disturbance levels of active power and reactive power for the required tests to be carried out.

Results obtained from off-site tests or factory tests may be used for model confirmation tests. Another approach adopted by power system equipment manufacturers is Hardware in Loop (HIL) testing to simulated Disturbances well before *plant* undergoes on-site commissioning and R2 model validation.

6.3.3. Post-connection model validation (R2)

R2 model validation is the final stage of providing evidence that the models submitted to AEMO and the NSP are of adequate quality to be used in *power system* studies to determine how to operate the *power system* securely. It is validated by comparing RMS and EMT model response to the *plant* installed at the site of interest.

For each relevant *performance standard* arising out of the technical requirements in [NER clause S5.2.5 of the NER](#), Table 6 describes the model validation required from the Applicant for the *plant* in question.

Table 6 Simulation tools required for R2 model validation (generating systems and integrated resource systems)

| Clause of the NER | RMS simulation tool | EMT simulation tool | Harmonic analysis tool |
|---|---------------------|---------------------|------------------------|
| S5.2.5.1 – Reactive Power Capability | ✓ | x | x |
| S5.2.5.2 – Quality of electricity generated | x | Maybe ^A | ✓ |
| S5.2.5.3 – Generating unit r Response to frequency disturbances | ✓ | x | x |
| S5.2.5.4 – Generating system r Response to voltage disturbances | ✓ | ✓ | x |
| S5.2.5.5 – Generating system r Response to disturbances following contingency events | ✓ | ✓ | x |
| S5.2.5.6 – Quality of electricity generated and continuous uninterrupted operation | x | ✓ | x |
| S5.2.5.7 – Partial Load Rejection | ✓ | x | x |
| S5.2.5.8 – Protection of generating systems from power system disturbances | ✓ | ✓ | x |
| S5.2.5.9 – Protection systems that impact on power system security ^B | - | - | - |
| S5.2.5.10 – Protection to trip plant for unstable operation ^B | - | - | - |
| S5.2.5.11 – Frequency control | ✓ | ✓ | x |
| S5.2.5.12 – Impact on network capability | ✓ | x | x |
| S5.2.5.13 – Voltage and reactive power control | ✓ | ✓ | x |
| S5.2.5.14 – Active Power Control | ✓ | ✓ | x |

A. If harmonic analysis tool fails to provide the required accuracy.
 B. Cannot be realistically validated by staged R2 tests.

C. This table specifies minimum requirements for R2 model validation, and should not be considered as the scope for the commissioning tests.

On-site tests

During commissioning, validation of model performance can be demonstrated by model overlays based on the tests outlined in the R2 test template for synchronous machines⁵⁸ and asynchronous ~~generation~~ technologies⁵⁹, and by continuous monitoring described below. For *network* and reactive support *plant*, relevant tests from these templates can be used to demonstrate model performance.

Continuous monitoring of disturbances

Congruence between *plant* and model dynamic responses for some aspects may be difficult to demonstrate until a *network* Disturbance occurs. It is, therefore, necessary that the Applicant develops a continuous monitoring program to demonstrate model accuracy for all major items comprising the *plant* (~~i.e. that is,~~ both at a ~~generating~~ system and ~~generating~~ unit level). As part of the compliance program developed in accordance with ~~NER clause 4.15 of the NER~~⁶⁰, high speed data collected during a Disturbance can be overlaid to demonstrate correct model responses. The Applicant must submit the model overlays to the NSP and AEMO for analysis and model verification as soon as possible following such a Disturbance.

~~In the absence of a detailed R2 commissioning process for IBLs, the validation of detailed IBL models may rely on the continuous monitoring of disturbances during the load operation.~~

Validation of Network User's model (for load)

Currently there is no R2 test template or guideline for a Network User's (load) facility. In the absence of a detailed R2 commissioning process for a Network User's (load) facility, AEMO will seek to determine the scope of model validation for these facilities with the NSP based on the following guiding principles:

- model validation may rely on the measurement, or other relevant information, obtained from project-specific commissioning activities as a part of the load connection process, which may be required by the NSP.
- The detailed models of IBL facilities, or aggregated IBL components within a Network User's (load) facility, should be subject to the same model validation process as that applicable to models for generating units and bidirectional units, as specified in these Guidelines.
- For non-IBL facilities, or non-IBL components within a Network User's (load) facility, the Applicant must seek the NSP's advice on the requirement of load facility commissioning.

These principles should not be taken to preclude different practices that may be prescribed in any future load R2 commissioning guideline.

⁵⁸ Available at: https://www.aemo.com.au/-/media/Files/Electricity/NEM/Network_Connections/Transmission-and-Distribution/Generating-System-Test-Plan-Template-for-Conventional-Synchronous-Machines.pdf

⁵⁹ Available at: https://www.aemo.com.au/-/media/Files/Electricity/NEM/Network_Connections/Transmission-and-Distribution/Generating-System-Test-Template-for-Non-Synchronous-Generation.pdf

⁶⁰ A compliance program instituted and maintained under ~~NER clause 4.15(b)~~ must ~~...~~ provide reasonable assurance of ongoing compliance with each applicable *performance standard*.

6.3.4. Numerical modelling artefacts and implication for model confirmation

Inaccuracies or undesired behaviours may be identified during validation or benchmarking tests on models, as well as prospective modelling results obtained in advance of field tests. For example:-

- The simulation software crashes, or otherwise cannot complete the simulation.
- The model output oscillates between two distinct values on alternate time steps.
- Spikes or large instantaneous changes in electrical quantities are observed in RMS simulations that are not reproduced in EMT simulations of the same event.

Such inaccuracies or undesired behaviours may arise due to numerical factors inherent in the model software environment, rather than the actual performance of the *plant*. Conversely, oscillatory responses or output changes that follow reasonably smooth trajectories in time and persist for one or more AC cycles are more likely to reflect real *plant* performance, particularly where these are seen in EMT modelling results.

The Applicant in consultation with its OEM(s) should take all reasonable steps to resolve any inaccuracies or undesired behaviours within the model, such that their impact on key output quantities is within the accuracy tolerances in section 6.2 of these Guidelines, subject to the following general guidance:

- Where a numerical artefact in a model materially restricts the conduct of reasonable due diligence on *plant* performance (and provision of reliable alternative evidence by the Applicant is not possible), resolution is required within the timeframe for assessment of proposed *access standards* by the NSP and AEMO under NER 5.3.4A.
- Otherwise, resolution is required prior to registration of the Applicant (where applicable) or, where registration is not applicable, prior to commencing commissioning of the relevant new or altered *plant*.
- When OEM remedies are not available, for example when updated models are required for legacy *plant* under Section 4.8.4 of these Guidelines:
 - A numerical artefact in a legacy *plant* model is acceptable to the extent it does not materially restrict the conduct of reasonable due diligence on *plant* performance.
 - EMT modelling evidence may be accepted in the absence of RMS modelling evidence to assess performance for specific *access standards* where the RMS model evidence is precluded by model performance issues.
 - Where available field test results for the existing (prior to any proposed alteration or change) legacy *plant* confirm the undesired model behaviour is not observed in reality, assessment of a new or altered *connection* may proceed on the basis of the test results. This does not otherwise affect the Applicant's obligations under Section 4.8.4 of these Guidelines.
 - Any permitted undesirable legacy model behaviours should to the extent practicable be contained to specific documented study scenarios.

6.4. Non-conformance with model accuracy requirements

Where AEMO or NSP determines that model inaccuracy outside the tolerances specified in Section 6.2.1 ~~presents manifests itself into~~ a risk to *power system security*, adverse impact on the performance of other *Network Users*, or inability meet ~~its~~ *performance standards*, the following action may be required by either the NSP or AEMO:

- Additional testing;
- Operational constraints imposed until the modelling issue can be resolved;
- Revised models or parameters verified by pre-commissioning model confirmation tests be submitted and accepted (revision may result in submission of a detailed vendor-specific model); or
- Any combination of these.

These requirements may persist or be repeated until the model accurately reflects the *plant's* response, and hence the *plant's* performance can be adequately predicted by *power system* studies.

2.7. Confidentiality of information and models provided

7.1. Storage and use by AEMO

AEMO's personnel have restricted access to data provided to AEMO by *Registered Participants* under the NER on a need-to-know basis.

Information obtained by AEMO under ~~the NER⁶⁴ and covered by these Guidelines clause S5.4.2 of the NER~~ is stored by AEMO on its systems, while the models so obtained are stored in AEMO's OPDMS for planning, operations, DSA and other applications. All information and models are used for the purpose for which they are intended to be used, consistent with the NER.

7.2. Intellectual property

These Guidelines do not affect the intellectual property rights in the information and models obtained by AEMO under ~~the NER clause S5.4.2 of the NER~~.

7.3. EMT model black-boxing, compilation or encryption

As ~~AEMO may be obliged to disclose~~ models ~~can be provided to other~~ *Registered Participants and certain other parties*, ~~Connection Applicants and project developers~~ under the NER, model owners may wish to black-box, compile or otherwise encrypt portions of an EMT model that are commercially sensitive, or where additional intellectual property protection is desired.

⁶⁴ See NER S5.5.7(b1)

Provided the requirements in these Guidelines as to the model's utility are met, and a legitimate user of the model is not hampered in their ability to carry out legitimate studies using the model, black-boxing is acceptable.

Model owners remain responsible for the adequacy of the black-boxing, compilation or other encryption of their model.

2.1.7.4. Provision of information and models to third parties

7.4.1. Generally

Requests for models and other information ~~must~~ may be directed to AEMO under ~~clause-NER 3.13.3(k), 3.13.3(l5) or 4.6.6(e) of the NER.~~ As the responsible party for the dissemination of models and other information under NER clause 3.13.3(l), AEMO will manage the ~~dissemination-disclosure~~ of models and other information held by AEMO in accordance with the NER and will only ~~disseminate it~~ disclose to the extent it is reasonably necessary for the purpose for which it is requested by a *Registered Participant*.

~~Clause-NER 3.13.3(l)~~ requires AEMO to provide information that is reasonably required by a *Registered Participant* to carry out *power system simulation* studies (including load flow and dynamic simulations) for planning and operational purposes. ~~and only some of T~~ that information must be treated as *confidential information*, ~~notably information related to the model source code~~⁶². *Registered Participants'* confidentiality obligations are set out in NER 8.6, and the NER ~~explicitly apply or allow to be applied those obligations to project developers and Connection Applicants who receive that information.~~

~~NER 3.13.3(l5)~~ requires AEMO in certain circumstances to provide ~~and~~ *power system and generating system* or integrated resource system model information ~~provided~~ to a *Transmission Network Service Provider* (TNSP) for planning and operational purposes which the TNSP must treat as confidential⁶³.

AEMO will update and *publish* the register it is required to maintain under ~~clause-NER 3.13.3(p1)~~ to include the fulfilment of all new requests for models and other information.

Table 7 summarises the type of model that AEMO will provide to a *Registered Participant* depending on the nature and reasonableness of the request.

⁶² See ~~clause-NER 3.13.3(l)(3)~~.

⁶³ See ~~clause-NER 3.13.3(l7)~~.

Table 7 Models to be provided by AEMO

| Data Requests | Application | |
|--|-----------------------------------|--|
| | System Strength Impact Assessment | Other Power System <u>Simulation Studies</u> |
| Generator and Integrated Resource Provider data (Section 7.4.2) | Not applicable | RMS (full) |
| Generator, Integrated Resource Provider and MNSP data (Section 7.4.3) | EMT (limited) ^{A+} | RMS (full) |
| NSP data (Section 7.4.4) | EMT full | RMS (full) & EMT full |
| <u>Network User data</u> | <u>EMT full</u> | <u>RMS (full) & EMT full</u> |

A. 'Limited' means that the contents of the model will be limited to those strictly necessary for the performance of a full system strength impact assessment, or whether the model was reasonably appropriate for conducting the full system strength impact assessment, as appropriate.

7.4.2. Reasonably required information

~~Clause NER 3.13.3(k2k1)~~ requires AEMO to set out in these Guidelines the circumstances in which ~~the information requested~~ under ~~clause NER 3.13.3(k)(2)~~ is considered to be 'reasonably required' by a *Registered Participant*. ~~The information referred to in clause NER 3.13.3(k)(2)~~ is information to carry out *power system simulation studies* (including load flow and dynamic simulations) for planning and operational purposes.

The remainder of this Section 7.34.2 details what AEMO considers to be 'reasonably required' ~~:~~

Generators, ~~and Integrated Resource Providers and Network Users~~

The information required to be provided under ~~clause NER 3.13.3(l)~~ and (l5) in respect of a *generating system or integrated resource system* ~~is~~ limited to that which AEMO holds and includes:

- The RUG, in unaltered form⁶⁴.
- Model source code, subject to the restrictions in ~~clause NER 3.13.3(l)(2)~~ and (l4), and permissions in ~~clause NER 3.13.3(l3)~~.
- Model information reasonably required by a TNSP for planning and operational purposes, subject to the requirements in ~~NER clause 3.13.3(l6)~~.

Generators, Integrated Resource Providers, Network Users, and Market Network Service Providers affected by a System Strength Impact Assessment

As stipulated by ~~clause NER 4.6.6(e) of the NER~~, where *plant* is subject to a full *system strength impact assessment*, AEMO is required to treat a request for the 'model' referred to in ~~clause NER 4.6.6(b)(2)~~ as a request under ~~clause NER 3.13.3(k)(2)~~ and provide the model to:

- The NSP required to carry out the full *system strength impact assessment*.
- Where only one Applicant is impacted by the *system strength impact assessment*, to that Applicant.

⁶⁴ See ~~NER clause 3.13.3(l)(1)~~.

- Where more than one Applicant is affected by the *system strength impact assessment* and, provided the NSP required to carry out the *system strength impact assessment* has complied with Section 4.2.3 of the *system strength impact assessment guidelines*, all affected Applicants to the extent that the impact of neighbouring *plant* (existing or proposed) needs to be accounted for in any new or altered *plant* design.

Network Service Providers

The information required to be provided under ~~clause-NER 3.13.3(l)~~ and (l5) in respect of a *network* or any *network element* is limited to that which AEMO holds and includes:

- Model source code, subject to the restrictions in ~~clause-NER 3.13.3(l)(2)~~ and (l6), and permissions in ~~clause-NER 3.13.3(l3)~~.

As specified in ~~NER clause 3.13.3(l3)~~, historical information, *network* dynamic model parameter values, a *network* model of the *national grid* suitable for load flow and fault studies, and other technical data listed in ~~NER Schedules S5.5.3~~ and ~~S5.5.4~~.

2.1.1.7.4.3. Confidentiality

Generators, ~~and Integrated Resource Providers and Network Users~~

Any model provided ~~by~~ under ~~clause-NER 3.13.3(l)~~ ~~and or~~ (l5) remains *confidential information* and can only be used by the recipient for the purpose permitted by ~~clause-NER 3.13.3(k)~~.

Generators, ~~Integrated Resource Providers, Network Users~~ and Market Network Service Providers affected by a System Strength Impact Assessment

Any model provided under ~~clause-NER 4.6.6(e)~~ remains *confidential information* and can only be used by the recipient to:

- In the case of the NSP, carry out the full *system strength impact assessment*.
- In the case of an Applicant, assess whether the model was reasonably appropriate for conducting the *system strength impact assessment*.

Network Service Providers

Any model provided under ~~clause-NER 3.13.3(l)~~ ~~or and~~ (l5) remains *confidential information* and can only be used by the recipient for the purpose permitted by ~~clause-NER 3.13.3(k)~~ ~~or (l5)~~ respectively.

8. Alternative process

Section 8 describes, where an Applicant cannot provide the required information or model within the prescribed timeframe for a reasonable cost, a process to be followed to give AEMO and the connecting NSP sufficient information to be able to fulfil the purpose for which the information or model is required.

8.1. Generally

Applicants whose *plant* does not meet the exemption criteria in Section 3.3 may apply for a variation to a requirement to provide specified data or models required by these Guidelines using the form contained in Appendix B.

8.2. Examples of requests

To assist *Registered Participants*, AEMO provides the following examples of cases where an application to vary a requirement under these Guidelines might be appropriate:

- Representation of pump storage and *generation* in the one model where there is no value to be gained by providing multiple models.
- Provision of model source code based on C or C++, rather than Fortran.
- Modelling of legacy *plant*, for example, related to matters discussed in Section 6.3.4 of these Guidelines.
- Development by AEMO of a PSCAD™/EMTDC™ model of a *synchronous generating unit* or *synchronous generating system*, where no other developer can be found, at the requestor's expense.

8.3. Consideration of request

AEMO must consider a request received in the form contained in Appendix B by reference to the following matters:

- The reasonable costs of efficient compliance by Applicants with these Guidelines and the Data Sheets compared to the likely benefits from the use of the information provided under those;
- Whether the information has been made available to AEMO in the past;
- NSPs' requirements for data and modelling information that is reasonably necessary for them to fulfil their obligations under the NER or jurisdictional electricity legislation;
- The model, and how it should be used;
- The potential impact of the *plant* to be connected on *power system security*;
- Quality of supply to *Network Users*;
- The calculation of *network* limits;
- The extent to which changes are expected to affect the operation of the *connection* under consideration;
- The ability for an NSP, AEMO, the Applicant, or any other party allowed under the NER to conduct studies for *connection applications* and access negotiations; and
- Any other matters AEMO considers to be reasonably relevant to a request.

8.4. Determination

Following consideration of the request, AEMO must:

- Accept or reject it;
- Propose options for the Applicant to consider; -or
- Request further information.

Appendix A. Application for exemption from the requirement to provide model and other information

APPLICATION FOR EXEMPTION FROM THE REQUIREMENT TO PROVIDE INFORMATION OR MODELS SPECIFIED IN THE POWER SYSTEM MODEL GUIDELINES

To enable a timely response to your Application please complete all sections of this form. Please use additional pages and attach supporting documentation where required.

| | |
|--|--|
| Applicant name | |
| Contact Details | |
| Name | |
| Phone | |
| Email | |
| Postal Address | |
| Date of Application | |
| Affected Plant | |
| Size of Plant | |
| Why Applicant should be granted an exemption (based on the grounds detailed in section 3.3 of the Power System Model Guidelines). | |
| Any other relevant information | |

Please send this application to: connections@aemo.com.au

Appendix B. Application to provide alternative model or information

APPLICATION TO PROVIDE ALTERNATIVE MODEL OR INFORMATION SPECIFIED IN THE POWER SYSTEM MODEL GUIDELINES

To enable a timely response to your Application please complete all sections of this form. Please use additional pages and attach supporting documentation where required.

| | |
|--|--|
| Applicant name | |
| Contact Details | |
| Name | |
| Phone | |
| Email | |
| Postal Address | |
| Date of Application | |
| Information or model requirement that cannot be met Include reference to section in the Guidelines where the requirement is specified. | |
| Why the requirement cannot be met. Include: <ul style="list-style-type: none"> • Evidence to substantiate reasons for being unable to meet the requirement; • Consideration of how this might affect AEMO or NSP’s ability to assess proposed access standards;- and • Discussion of alternative options considered, sufficient to satisfy the NSP and AEMO that meeting the requirement is technically unachievable. | |
| Proposed Alternative Information or Model to be provided Include a description of the discrepancy between the relevant requirement and what is proposed to be provided and a discussion of how the alternative is a reasonable equivalent of the requirement that cannot be met. | |
| Proposed date by which Alternative Information or Model will be provided | |

Please send this application to: connections@aemo.com.au

Appendix C. Modelling component requirements

Appendix C sets out components that are required to be included in models based on the *plant*, studies being completed and the tool being used. These tables focus on physical components to be included within models. As load flow and fault level studies are based on Newtonian solution methods, these study types are excluded from all tables in this appendix.

C.1 Definitions and notes

C.1.1 Protection systems

Experience has shown that protective functions of *plant* can have a major impact on stability of the *generating system* or *integrated resource system* and the *power system*. Reference to “protection” in the following table and footnotes includes:

- High and low *voltage* protection;
- Over- and under-*frequency* protection;
- Rate of change of *frequency* protection;
- Multiple fault ride-through protection;
- Loss of excitation protection;
- Over-flux (V/Hz) protection;
- Out-of-step protection;
- Negative phase sequence (voltage unbalance) protection⁶⁵;
- Reverse *active power* protection;
- Torsional stress protection⁶⁶; ~~and~~

⁶⁵ Where the underlying simulation tool allows negative phase sequences to be evaluated.

⁶⁶ This is a relatively uncommon protection relay – the *Generator* must determine whether the exclusion of this relay from the model has a material impact on model accuracy.

- Unit transformer and generator differential protection; and-
- Any Remedial Action Schemes that have been deemed to have material impact on the system⁶⁷.

All protection systems included in the models must be consistent with the plant's performance standard.

C.1.2 Control loops

The representation of control loops in converter-connected technology is of particular importance for assessing transient stability of *plant*. Where the following terms are included within tables, the sub-points indicate the control loops that are expected to be represented within the model.

Outer loop converter control

- Active power and reactive power control_;
- Active torsional damping (if applicable)_;
- Fast acting *voltage* control (if applicable)_;
- Fast acting *frequency* control (if applicable).

Inner control loop

- DC link current control_;
- DC link *voltage* control_;
- Rotor-side current control (if applicable).
- Grid-side current control (if applicable)

⁶⁷ See the Remedial Action Scheme Guidelines for more information.

C.1.3 High-frequency transient models

Only *plant* involved in *power system* restoration, including SRAS sources, are required to provide high-frequency transient models. These models must represent fast- and slow-front transients as defined by the IEC Standard 60071 Part 1.

C.2 Wind generation

- Models to be aggregated as per Section 4.7.
- Measurements feeding into controls must include relevant filtering and delays.
- Winding ratios of VTs and CTs feeding protection mechanisms must be provided.

C.2.1 Turbine model components

Elements marked with an asterisk (*) require the Applicant to determine whether the component needs to be included to accurately represent the *plant* response for the phenomena of interest.

| Component Study | Aerodynamics | Pitch controller | Mechanical drive train | Torsional damping | Electrical generator ^A | Dynamic braking resistor / chopper | DC link | IGBT switches and PWM switching | Unit transformer ^B |
|------------------------------|--------------|------------------|------------------------|-------------------|-----------------------------------|------------------------------------|----------|---------------------------------|-------------------------------|
| Transient stability | RMS*, EMT* | RMS*, EMT* | RMS*, EMT* | RMS*, EMT* | RMS, EMT | RMS, EMT | RMS, EMT | - | RMS, EMT |
| Sub-synchronous interactions | EMT* | EMT* | EMT | EMT | EMT | EMT | EMT | - | EMT |
| High-frequency transient | - | - | - | - | EMT | - | EMT* | EMT | EMT |
| Harmonics | EMT* | EMT* | EMT* | EMT* | EMT | EMT | EMT | EMT | EMT |

A. Fifth-order generator.

B. Including saturation for EMT models. ~~For RMS models it is acceptable to represent three-winding transformers as two-winding equivalents.~~

| Component \ Study | Internal filters | Inner loop converter control | Outer loop converter control | Phase locked loop ^A | Frequency control ^B | High voltage ride-through | Low voltage ride-through | Multiple fault ride-through limitations | Protection |
|------------------------------|------------------|------------------------------|------------------------------|--------------------------------|--------------------------------|---------------------------|--------------------------|---|------------|
| Transient Stability | RMS, EMT | EMT | RMS, EMT | EMT | RMS, EMT | RMS, EMT | RMS, EMT | RMS, EMT | RMS, EMT |
| Sub-synchronous interactions | EMT | EMT | EMT | EMT | EMT | EMT | EMT | EMT | EMT |
| High-frequency transient | EMT | EMT* | EMT* | EMT* | - | EMT | - | - | EMT |
| Harmonics | EMT | EMT | EMT | EMT | EMT | - | - | - | - |

A. Explicit representation.

B. Including *frequency* raise and lower, *frequency* droop and deadbands.

C.1.C.2.2 Balance of plant model components

| Component \ Study | Park controller ^A | Other coordinated control systems | Reticulation Network | Static reactive support plant ^B | Dynamic reactive support plant ^C | Connection point transformers ^D | Transformer onload tap changer controllers |
|------------------------------|------------------------------|-----------------------------------|----------------------|--|---|--|--|
| Transient Stability | RMS, EMT | RMS, EMT | RMS, EMT | RMS, EMT | RMS, EMT | RMS, EMT | RMS, EMT |
| Sub-synchronous interactions | EMT | EMT | EMT | EMT | EMT | EMT | - |
| High-frequency transient | - | - | EMT | EMT | EMT | EMT | - |
| Harmonics | EMT* | EMT* | EMT | EMT | EMT | EMT | - |

A. Including delays that affect performance, controls and outputs for *reactive power* support *plant*, controls for *active power*, *reactive power*, *voltage*, *power factor* and *frequency*, and any participation in fault ride-through protection.

B. Details of switching philosophy to be provided in the RUG.

C. Including full *voltage* controller representation and relevant protection mechanisms.

D. Including saturation for EMT models. ~~For RMS models it is acceptable to represent three-winding transformers as two-winding equivalents.~~

C.3 Photovoltaic generation

- Models to be aggregated as per Section 4.7.
- Measurements feeding into controls must include relevant filtering and delays.

- Winding ratios of VTs and CTs feeding protection mechanisms must be provided.

C.3.1 Inverter model components

Elements marked with an asterisk (*) require the Applicant to determine whether the component needs to be included to accurately represent the *plant* response for the phenomena of interest.

| Component \ Study | Solar Cells | DC-DC converter | DC link | IGBT switches | PWM switching | Unit transformer ^A | Internal filters |
|------------------------------|-------------|-----------------|----------|---------------|---------------|-------------------------------|------------------|
| Transient Stability | EMT* | RMS, EMT | RMS, EMT | - | - | RMS, EMT | RMS, EMT |
| Sub-synchronous interactions | - | EMT | EMT | - | - | EMT | EMT |
| High-frequency transient | - | EMT* | EMT* | EMT | EMT | EMT | EMT |
| Harmonics | - | EMT | EMT | EMT | EMT | EMT | EMT |

A. Including saturation for EMT models. ~~For RMS models it is acceptable to represent three-winding transformers as two-winding equivalents.~~

| Component \ Study | Inner loop converter control | Outer loop converter control | Phase locked loop ^A | Frequency control ^B | High voltage ride-through | Low voltage ride-through | Multiple fault ride-through limitations | Protection |
|------------------------------|------------------------------|------------------------------|--------------------------------|--------------------------------|---------------------------|--------------------------|---|------------|
| Transient Stability | EMT | RMS, EMT | EMT | RMS, EMT | RMS, EMT | RMS, EMT | RMS, EMT | RMS, EMT |
| Sub-synchronous interactions | EMT | EMT | EMT | EMT | EMT | EMT | - | EMT |
| High-frequency transient | EMT* | EMT* | EMT* | - | EMT | - | - | EMT |
| Harmonics | EMT | EMT | EMT | EMT | - | - | - | - |

A. Explicit representation.

B. Including *frequency* raise and lower, *frequency* droop and deadbands.

C.1.2C.3.2 Balance of plant model components

| Component \ Study | Park controller ^A | Other coordinated control systems | Reticulation Network | Static reactive support plant ^B | Dynamic reactive support plant ^C | Connection point transformers ^D | Transformer onload tap changer controllers |
|------------------------------|------------------------------|-----------------------------------|----------------------|--|---|--|--|
| Transient Stability | RMS, EMT | RMS, EMT | RMS, EMT | RMS, EMT | RMS, EMT | RMS, EMT | RMS, EMT |
| Sub-synchronous interactions | EMT | EMT | EMT | EMT | EMT | EMT | - |
| High-frequency transient | - | - | EMT | EMT | EMT | EMT | - |
| Harmonics | EMT* | EMT* | EMT | EMT | EMT | EMT | - |

A. Including delays that affect performance, controls and outputs for *reactive power support plant*, controls for *active power, reactive power, voltage, power factor* and *frequency*, and any participation in fault ride-through protection.

B. Details of switching philosophy to be provided in the RUG.

C. Including full *voltage* controller representation and relevant protection mechanisms.

D. Including saturation for EMT models. ~~For RMS models it is acceptable to represent three-winding transformers as two-winding equivalents.~~

C.4 Converter-based energy storage systems

- Models to be aggregated as per Section 4.7.
- Measurements feeding into controls must include relevant filtering and delays.
- Winding ratios of VTs and CTs feeding protection mechanisms must be provided.

C.4.1 Converter model components

Elements marked with an asterisk (*) require the Applicant to determine whether the component needs to be included to accurately represent the *plant* response for the phenomena of interest.

| Component \ Study | Energy storage (battery, super-capacitor) | DC-DC converter | DC link | IGBT switches | PWM switching | Unit transformer ^A | Internal filters |
|------------------------------|---|-----------------|----------|---------------|---------------|-------------------------------|------------------|
| Transient Stability | EMT* | RMS, EMT | RMS, EMT | - | - | RMS, EMT | RMS, EMT |
| Sub-synchronous interactions | - | EMT | EMT | - | - | EMT | EMT |
| High-frequency transient | - | EMT* | EMT* | EMT | EMT | EMT | EMT |
| Harmonics | - | EMT | EMT | EMT | EMT | EMT | EMT |

A. Including saturation for EMT models. ~~For RMS models it is acceptable to represent three-winding transformers as two-winding equivalents.~~

| Component \ Study | Inner loop converter control | Outer loop converter control | Phase locked loop ^A | Frequency control ^B | High voltage ride-through | Low voltage ride-through | Multiple fault ride-through limitations | Protection |
|------------------------------|------------------------------|------------------------------|--------------------------------|--------------------------------|---------------------------|--------------------------|---|------------|
| Transient Stability | EMT | RMS, EMT | EMT | RMS, EMT | RMS, EMT | RMS, EMT | RMS, EMT | RMS, EMT |
| Sub-synchronous interactions | EMT | EMT | EMT | EMT | EMT | EMT | - | EMT |
| High-frequency transient | EMT* | EMT* | EMT* | - | EMT | - | - | EMT |
| Harmonics | EMT | EMT | EMT | EMT | - | - | - | - |

A. Explicit representation.

B. Including *frequency* raise and lower, *frequency* droop and deadbands.

C.1.3C.4.2 Balance of plant model components

| Component \ Study | Park controller ^A | Other coordinated control systems | Reticulation Network | Static reactive support plant ^B | Dynamic reactive support plant ^C | Connection point transformers ^D | Transformer onload tap changer controllers |
|------------------------------|------------------------------|-----------------------------------|----------------------|--|---|--|--|
| Transient Stability | RMS, EMT | RMS, EMT | RMS, EMT | RMS, EMT | RMS, EMT | RMS, EMT | RMS, EMT |
| Sub-synchronous interactions | EMT | EMT | EMT | EMT | EMT | EMT | - |
| High-frequency transient | - | - | EMT | EMT | EMT | EMT | - |
| Harmonics | EMT* | EMT* | EMT | EMT | EMT | EMT | - |

A. Including delays that affect performance, controls and outputs for *reactive power support plant*, controls for *active power, reactive power, voltage, power factor and frequency*, and any participation in fault ride-through protection.

B. Details of switching philosophy to be provided in the RUG.

C. Including full *voltage* controller representation and relevant protection mechanisms.

D. Including saturation for EMT models. ~~For RMS models it is acceptable to represent three-winding transformers as two-winding equivalents.~~

C.5 Inverter--based load

- Models to be aggregated as per Section 4.7.
- Measurements feeding into controls must include relevant filtering and delays.
- Winding ratios of VTs and CTs feeding protection mechanisms must be provided.
- Inclusion of model components depends on actual load configuration.
- Applicable to detailed load models only (not applicable to IEEE ZIP or Composite load model)

C.5.1 Converter model components

Elements marked with an asterisk (*) require the Applicant to determine whether the component needs to be included to accurately represent the plant response for the phenomena of interest.

| Component \ Study | Energy storage (battery, super-capacitor) | DC-DC converter | DC link | IGBT switches | PWM switching | Unit transformer ^A | Internal filters |
|-------------------------------------|---|-----------------|-----------------|---------------|---------------|-------------------------------|------------------|
| Transient Stability | <u>EMT*</u> | <u>RMS, EMT</u> | <u>RMS, EMT</u> | <u>-</u> | <u>-</u> | <u>RMS, EMT</u> | <u>RMS, EMT</u> |
| Sub-synchronous interactions | <u>-</u> | <u>EMT</u> | <u>EMT</u> | <u>-</u> | <u>-</u> | <u>EMT</u> | <u>EMT</u> |
| High-frequency transient | <u>-</u> | <u>EMT*</u> | <u>EMT*</u> | <u>EMT</u> | <u>EMT</u> | <u>EMT</u> | <u>EMT</u> |
| Harmonics | <u>-</u> | <u>EMT</u> | <u>EMT</u> | <u>EMT</u> | <u>EMT</u> | <u>EMT</u> | <u>EMT</u> |

A. Including saturation for EMT models. For RMS models it is acceptable to represent three-winding transformers as two-winding equivalents.

| Component \ Study | Inner loop converter control | Outer loop converter control | Phase locked loop ^A | Frequency control ^B | High voltage ride-through | Low voltage ride-through | Multiple fault ride-through limitations | Protection ^C |
|-------------------------------------|------------------------------|------------------------------|--------------------------------|--------------------------------|---------------------------|--------------------------|---|-------------------------|
| Transient Stability | <u>EMT</u> | <u>RMS, EMT</u> | <u>EMT</u> | <u>RMS, EMT</u> | <u>RMS, EMT</u> | <u>RMS, EMT</u> | <u>RMS, EMT</u> | <u>RMS, EMT</u> |
| Sub-synchronous interactions | <u>EMT</u> | <u>EMT</u> | <u>EMT</u> | <u>EMT</u> | <u>EMT</u> | <u>EMT</u> | <u>-</u> | <u>EMT</u> |
| High-frequency transient | <u>EMT*</u> | <u>EMT*</u> | <u>EMT*</u> | <u>-</u> | <u>EMT</u> | <u>-</u> | <u>-</u> | <u>EMT</u> |
| Harmonics | <u>EMT</u> | <u>EMT</u> | <u>EMT</u> | <u>EMT</u> | <u>-</u> | <u>-</u> | <u>-</u> | <u>-</u> |

A. Explicit representation.

B. Including frequency raise and lower, frequency droop and deadbands.

C. The Applicant should seek the NSP's advice on the level of details to be included for protection system models for non-IBL facilities.

C.5.2 Balance of plant model component

| Study \ Component | Park controller^A | Other coordinated control systems | Rectification Network | Static reactive support plant^B | Dynamic reactive support plant^C | Connection point transformers^D | Transformer onload tap changer controllers |
|-------------------------------------|------------------------------------|--|------------------------------|--|---|--|---|
| Transient Stability | <u>RMS, EMT</u> | <u>RMS, EMT</u> | <u>RMS, EMT</u> | <u>RMS, EMT</u> | <u>RMS, EMT</u> | <u>RMS, EMT</u> | <u>RMS, EMT</u> |
| Sub-synchronous interactions | <u>EMT</u> | <u>EMT</u> | <u>EMT</u> | <u>EMT</u> | <u>EMT</u> | <u>EMT</u> | = |
| High-frequency transient | = | = | <u>EMT</u> | <u>EMT</u> | <u>EMT</u> | <u>EMT</u> | = |
| Harmonics | <u>EMT*</u> | <u>EMT*</u> | <u>EMT</u> | <u>EMT</u> | <u>EMT</u> | <u>EMT</u> | = |

A. Including delays that affect performance, controls and outputs for reactive power support plant, controls for active power, reactive power, voltage, power factor and frequency, and any participation in fault ride-through protection.

B. Details of switching philosophy to be provided in the RUG.

C. Including full voltage controller representation and relevant protection mechanisms.

D. Including saturation for EMT models. For RMS models it is acceptable to represent three-winding transformers as two-winding equivalents.

C.6 High voltage DC link

- Measurements feeding into controls must include relevant filtering and delays.
- Winding ratios of VTs and CTs feeding protection mechanisms must be provided.

C.6.1 Inverter/rectifier model components

Elements marked with an asterisk (*) require the Applicant to determine whether the component needs to be included to accurately represent the *plant* response for the phenomena of interest.

| Component / Study | HVDC cable/line | IGBT switches / thyristors | PWM switching / firing pulses | AC and DC filters | Link transformer ^A | Static reactive support plant ^B | Dynamic reactive support plant ^C | Transformer onload tap changer controllers |
|------------------------------|-----------------|----------------------------|-------------------------------|-------------------|-------------------------------|--|---|--|
| Transient Stability | RMS, EMT | EMT | EMT | RMS, EMT | RMS, EMT | RMS, EMT | RMS, EMT | RMS, EMT |
| Sub-synchronous interactions | EMT | - | - | EMT | EMT | EMT | EMT | - |
| High-frequency transient | EMT | EMT* | EMT* | EMT | EMT | EMT | EMT | - |
| Harmonics | EMT | EMT | EMT | EMT | EMT | EMT | EMT | - |

A. Including saturation for EMT models.

B. Details of switching philosophy to be provided in the RUG.

C. Including full *voltage* controller representation and relevant protection mechanisms.

| Component / Study | Inner loop converter control (if applicable) | Outer loop converter control | Phase locked loop ^A | Frequency control ^B | High voltage ride-through | Low voltage ride-through | Other coordinated control systems | Multiple fault ride-through limitations | Protection |
|------------------------------|--|------------------------------|--------------------------------|--------------------------------|---------------------------|--------------------------|-----------------------------------|---|------------|
| Transient Stability | EMT | RMS, EMT | EMT | RMS, EMT | RMS, EMT | RMS, EMT | RMS, EMT | RMS, EMT | RMS, EMT |
| Sub-synchronous interactions | EMT | EMT | EMT | EMT | EMT | EMT | EMT | - | EMT |
| High-frequency transient | EMT* | EMT* | EMT* | - | EMT | - | - | - | EMT |
| Harmonics | EMT | EMT | EMT | EMT | - | - | EMT* | - | - |

A. Explicit representation.

B. Including *frequency* raise and lower, *frequency* droop and deadbands.

C.7 Synchronous machines and generators

- Measurements feeding into controls must include relevant filtering and delays.
- Winding ratios of VTs and CTs feeding protection mechanisms must be provided.

C.7.1 Generator model components

Elements marked with an asterisk (*) require the Applicant to determine whether the component needs to be included to accurately represent the *plant* response for the phenomena of interest.

| Study \ Component | Generator ^A | Mechanical drive train (inc. turbine, flywheel etc.) | Torsional damping | Governor ^B | Power system stabiliser | Unit transformer ^C | Exciter | Automatic voltage regulator ^D |
|------------------------------|------------------------|--|-------------------|-----------------------|-------------------------|-------------------------------|----------|--|
| Transient Stability | RMS, EMT | EMT* | EMT* | RMS, EMT | RMS, EMT | RMS, EMT | RMS, EMT | RMS, EMT |
| Sub-synchronous interactions | EMT | EMT | EMT | EMT | EMT | EMT | EMT | EMT |
| High-frequency transient | EMT | - | - | EMT | EMT | EMT | EMT | EMT |
| Harmonics | EMT | - | - | - | - | EMT | EMT | EMT |

- A. Full saturation curve required for EMT models.
- B. Including *frequency* control, droop, deadbands and isochronous mode.
- C. Including saturation characteristics for EMT models.
- D. Including compensator and derived measurements.

| Study \ Component | Excitation limiters ^{EA} | Transformer onload tap changer controllers | Multiple fault ride-through limitations | Protection |
|------------------------------|-----------------------------------|--|---|------------|
| Transient Stability | RMS, EMT | RMS, EMT | RMS, EMT | RMS, EMT |
| Sub-synchronous interactions | EMT | - | - | EMT |
| High-frequency transient | EMT | - | - | EMT |
| Harmonics | EMT | - | - | - |

^{EA} Including all applicable limiters in over- and under-excited range (e.g. for example, over-excitation limiter, under-excitation limiter, V/Hz limiter, PQ limiters-etc.).

C.8 Converter-based reactive support systems

- Including SVCs, STATCOMs, etc.
- Measurements feeding into controls must include relevant filtering and delays.

- Winding ratios of VTs and CTs feeding protection mechanisms must be provided.

C.8.1 Reactive support model components

Elements marked with an asterisk (*) require the Applicant to determine whether the component needs to be included to accurately represent the *plant* response for the phenomena of interest.

| Component \ Study | DC link componentry | Thyristor / IGBT switches | PWM switching / firing control | Unit transformer ^A | Internal filters | External shunt devices and filters ^B |
|------------------------------|---------------------|---------------------------|--------------------------------|-------------------------------|------------------|---|
| Transient Stability | EMT* | - | - | RMS, EMT | RMS, EMT | RMS, EMT |
| Sub-synchronous interactions | - | - | - | EMT | EMT | EMT |
| High-frequency transient | - | EMT | EMT | EMT | EMT | EMT |
| Harmonics | - | EMT | EMT | EMT | EMT | EMT |

A. Including saturation for EMT models. ~~For RMS models it is acceptable to represent three-winding transformers as two-winding equivalents.~~

B. Including any control of external shunts from *plant* controller.

| Component \ Study | Inner loop converter control | Outer loop converter control | Phase locked loop ^A | Frequency control ^B | Power oscillation damping control | High voltage ride-through | Low voltage ride-through | Multiple fault ride-through limitations | Protection |
|------------------------------|------------------------------|------------------------------|--------------------------------|--------------------------------|-----------------------------------|---------------------------|--------------------------|---|------------|
| Transient Stability | EMT | RMS, EMT | EMT | RMS, EMT | RMS, EMT | RMS, EMT | RMS, EMT | RMS, EMT | RMS, EMT |
| Sub-synchronous interactions | EMT | EMT | EMT | EMT | EMT | EMT | EMT | - | EMT |
| High-frequency transient | EMT* | EMT* | EMT* | - | EMT | EMT | - | - | EMT |
| Harmonics | EMT | EMT | EMT | EMT | EMT | - | - | - | - |

A. Explicit representation.

B. Including *frequency* raise and lower, *frequency* droop and deadbands.

Appendix D. Quantities to be assessed for transient and voltage analysis

The following table outlines the quantities that have the accuracy requirements of Section 6.2 applied, based on the test or Disturbance of interest. Quantities that are not applicable to the *plant* under consideration should be ignored (e.g. for example, field *voltage* for a photovoltaic inverter).

The accuracy of EMT model responses are evaluated on their simulation-tool calculated RMS quantities, with filtering appropriate for a 50-Hz nominal system.

| Test / Disturbance | Perturbed quantity | Measured quantity | | |
|--------------------------------------|--|--------------------------------------|--|--------------------------------------|
| Voltage Reference Step | Voltage reference (<i>production generating unit</i> or centralised controller) | Plant terminal active power | | |
| | | Plant terminal reactive power | | |
| | | Connection point active power | | |
| | | Connection point reactive power | | |
| | | Centralised controller dispatch Pref | | |
| | | Centralised controller dispatch Qref | | |
| | | Field voltage | | |
| | | Field current (EMT only) | | |
| | | Relevant limiter output | | |
| | | Stabiliser output | | |
| Power Factor Reference Step | Power factor reference (<i>production unit generating unit</i> or centralised controller) | AVR output | | |
| | | Stator voltage | | |
| | | Plant terminal voltage | | |
| | | Connection point voltage | | |
| | | Centralised controller dispatch Vref | | |
| | | Reactive Power Reference Step | Reactive power reference (<i>production unit generating unit</i> or centralised controller) | Plant terminal active power |
| | | | | Plant terminal reactive power |
| | | | | Connection point active power |
| | | | | Connection point reactive power |
| | | | | Centralised controller dispatch Pref |
| Centralised controller dispatch Qref | | | | |
| Active Power Reference Step | Active power reference (<i>production unit generating unit</i> or centralised controller) | | | Plant terminal active power |
| | | | | Plant terminal reactive power |
| | | | | Connection point active power |
| | | | | Connection point reactive power |
| | | Centralised controller dispatch Pref | | |
| | | Centralised controller dispatch Qref | | |
| | | External Voltage Step | Switched shunt, transformer tap, or other external voltage change | Plant terminal active power |
| | | | | Plant terminal reactive power |
| | | | | Connection point active power |
| | | | | Connection point reactive power |
| Centralised controller dispatch Pref | | | | |
| Centralised controller dispatch Qref | | | | |
| Energy Source Change | Wind speed or solar irradiance | | | Plant terminal active power |
| | | | | Plant terminal reactive power |
| | | | | Connection point active power |
| | | | | Connection point reactive power |
| | | Centralised controller dispatch Pref | | |
| | | Centralised controller dispatch Qref | | |

| Test / Disturbance | Perturbed quantity | Measured quantity |
|--------------------------------------|--------------------|--------------------------------------|
| | | Plant terminal voltage |
| | | Connection point voltage |
| | | Centralised controller dispatch Vref |
| External Voltage Angle Step | Voltage angle | Plant terminal active power |
| | | Plant terminal reactive power |
| | | Point of Connection active power |
| | | Point of Connection reactive power |
| | | Centralised controller dispatch Pref |
| | | Centralised controller dispatch Qref |
| | | Field voltage |
| | | Field current (EMT only) |
| | | Rotor Angle |
| | | Stabiliser output |
| | | Stator voltage |
| | | Plant terminal voltage |
| | | Point of Connection voltage |
| | | Centralised controller dispatch Vref |
| | | Voltage Disturbance |
| Plant terminal reactive power | | |
| Point of Connection active power | | |
| Point of Connection reactive power | | |
| Centralised controller dispatch Pref | | |
| Centralised controller dispatch Qref | | |
| Field voltage | | |
| Field current (EMT only) | | |
| Rotor Angle | | |
| Stabiliser output | | |
| Stator voltage | | |
| Relevant limiter output | | |
| AVR output | | |

| Test / Disturbance | Perturbed quantity | Measured quantity |
|----------------------------------|--|--------------------------------------|
| | | Plant terminal voltage |
| | | Point of Connection voltage |
| | | Centralised controller dispatch Vref |
| Frequency Disturbance | Connection point frequency (network event) | Plant terminal active power |
| External Frequency change | <u>Production unit Unit</u> or centralised controller frequency bias injection | Centralised controller dispatch Pref |
| | | Stabiliser output |
| | | AVR output |
| | | Governor control output |
| | | Governor valve position |
| | | Relevant limiter output |

Appendix E. Transient window definitions

The transient window definition is based on the model response, as the model will likely return to a clear Steady State, while due to natural network fluctuations the Steady State of the *plant's* measured response may be more difficult to discern.

Due to the inherently varied nature of transient responses, the following are provided as a guide only.

E.1 Transient window for an uncontrolled change

Transient Window - Uncontrolled Change (Disturbance)

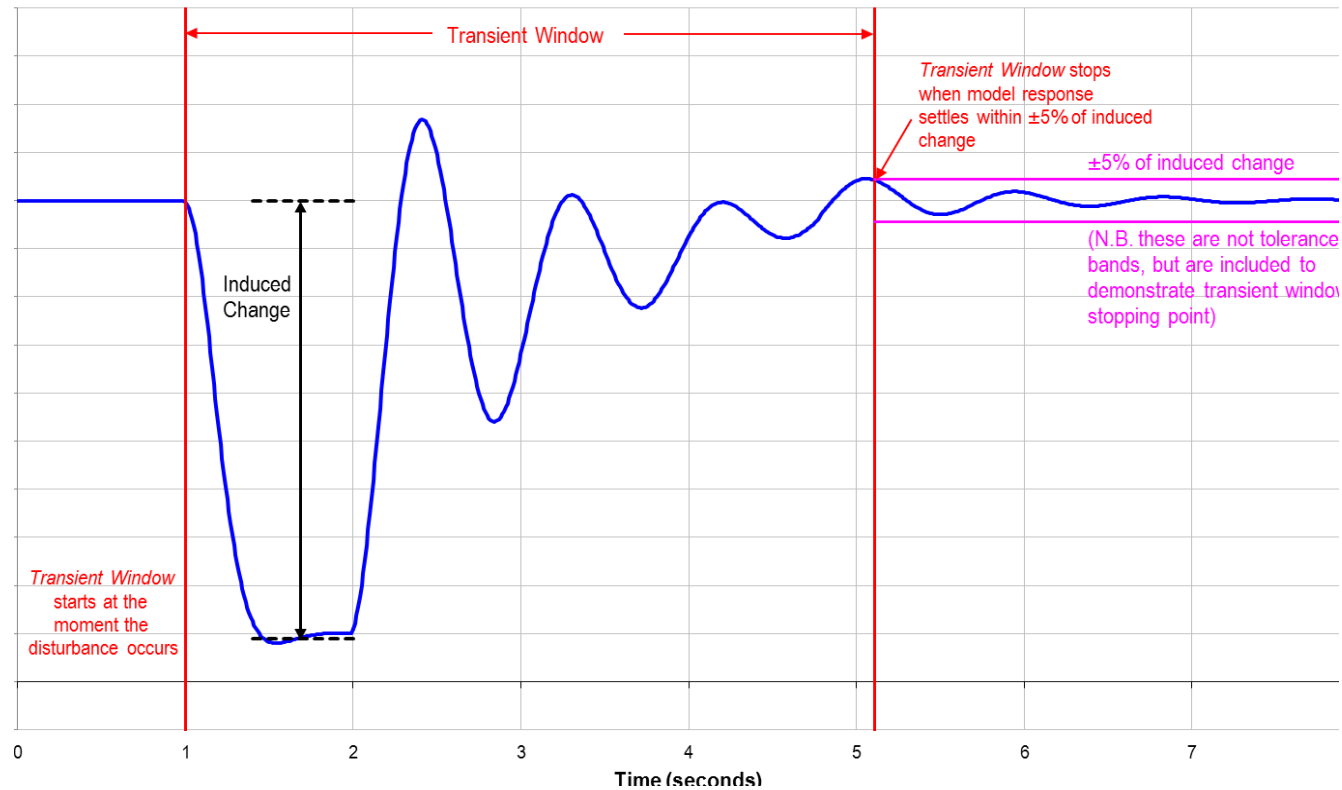

E.2 Transient window for a controlled change

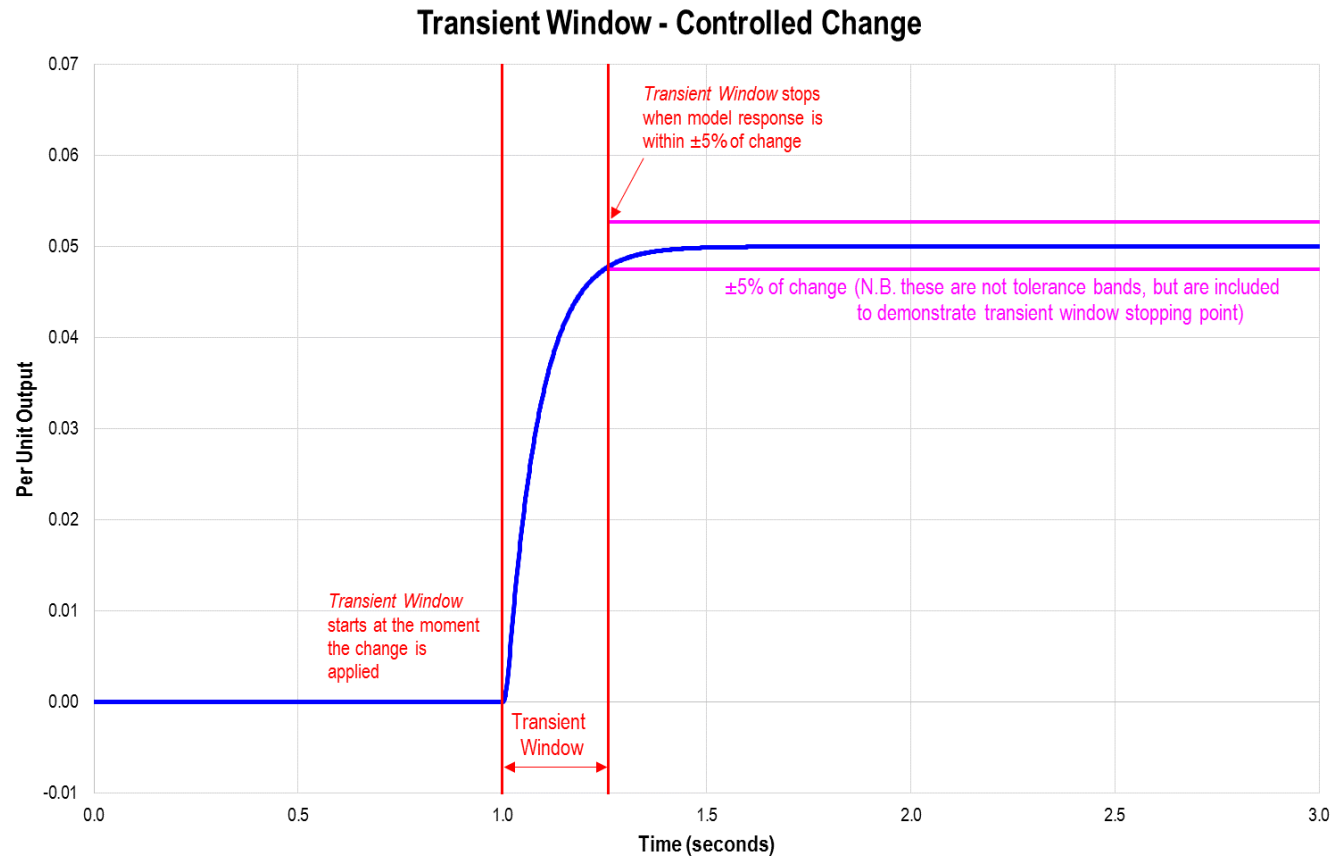

Version release history

| Version | Effective date | Summary of changes |
|---------------------|-------------------------------|--|
| 1.0 | 1 July 2018 | First version following Final Determination |
| 2.0 | 147 July 2023 | Second version following 2023 consultation |